

8. SPARE PARTS

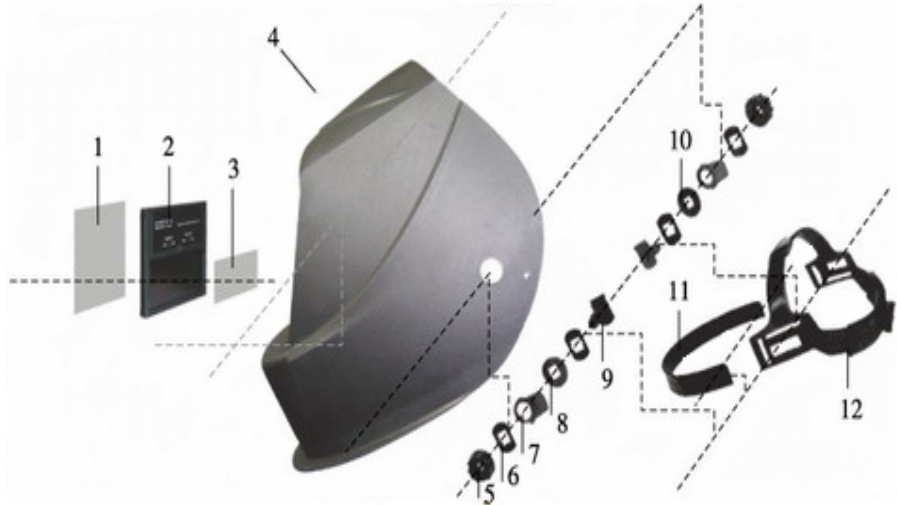

1	Front Cover Lens	PWH199.01	7	Limitation Washer	PWH199.07
2	Auto-Darkening Cartridge	PWH199.02	8	Left Limitation Washer	PWH199.08
3	Inside Cover Lens	PWH199.03	9	Screw (2)	PWH199.09
4	Headshield	PWH199.04	10	Right Limitation Washer	PWH199.10
5	Block Nut (2)	PWH199.05	11	Front Headband c/w Sweatband	PWH199.11
6	Washer (4)	PWH199.06	12	Adjustable Headband	PWH199.12

9. DECLARATION OF CONFORMITY

Declaration of Conformity. We, the sole importer into the UK, declare that the product listed here is in conformity with the following standards and directives.

Welding Helmet Solar Powered Shade 11
Model No. PWH199
 BSEN175
 BSEN379
 2002/95/EC RoHS Directive
 2002/96/EC WEEE Directive
 93/68/EEC CE Marking Directive



The construction file for this product is held by the Manufacturer and may be inspected on request by contacting Jack Sealey Ltd

Signed by Steve Buckle *Steve Buckle* 22nd April 2008

For Jack Sealey Ltd. Sole importer into the UK of Sealey Power Products

NOTE: It is our policy to continually improve products and as such we reserve the right to alter data, specifications and component parts without prior notice.

IMPORTANT: No liability is accepted for incorrect use of this equipment.

WARRANTY: Guarantee is 12 months from purchase date, proof of which will be required for any claim.

INFORMATION: Call us for a copy of our latest catalogue on 01284 757525 and leave your full name and address including your postcode.



Sole UK Distributor
Sealey Group,
 Bury St. Edmunds, Suffolk.

01284 757500
 01284 703534

www.sealey.co.uk
 sales@sealey.co.uk

PWH199 Issue No: 1 - 22/04/08

SEALEY POWER WELDERS

INSTRUCTIONS FOR:
**WELDING HELMET SOLAR
 POWERED SHADE 11**
 MODEL NO: PWH199

Thank you for purchasing a Sealey Power Product. Manufactured to a high standard this product will, if used according to these instructions and properly maintained, give you years of trouble free performance.



IMPORTANT: PLEASE READ THESE INSTRUCTIONS CAREFULLY. NOTE THE SAFE OPERATIONAL REQUIREMENTS, WARNINGS AND CAUTIONS. USE THIS PRODUCT CORRECTLY AND WITH CARE FOR THE PURPOSE FOR WHICH IT IS INTENDED. FAILURE TO DO SO MAY CAUSE DAMAGE OR PERSONAL INJURY AND WILL INVALIDATE THE WARRANTY. PLEASE KEEP INSTRUCTIONS SAFE FOR FUTURE USE.

1. SAFETY INSTRUCTIONS

- WARNING! THIS HELMET IS NOT SUITABLE FOR USE WITH LASER OR GAS WELDING/CUTTING.**
- ✓ Ensure all workshop safety rules, regulations and conditions are complied with when using welding equipment. The helmet will not offer protection against misuse of workshop tools, equipment, or accessories.
- ✓ Maintain the helmet in good condition and protect cartridge from liquid and dirt contact. Regularly replace the protective lens and replace any damaged or worn parts. *Use genuine parts only. Unauthorised parts may be dangerous and will invalidate the warranty.*
- ✓ Ensure the front cover lens is securely in place before use.
- ✓ Fit the helmet and adjust the head band so the helmet will sit as low and near to your face as possible.
- ✓ Use helmet only in temperatures ranging from -10°C to 70°C (14°F to 158°F).
- ✓ Remove ill fitting clothing, remove ties, watches, rings and other loose jewellery.
- ✓ Maintain correct balance and footing.
- ✓ Ensure the floor is clear from obstructions, not slippery and wear non-slip shoes.
- ✓ Keep children and unauthorised persons away from the working area.
- WARNING!** The helmet will only protect the eyes and face from radiation and sparks. It will not protect against explosive devices or corrosive liquids.
- x **DO NOT** use helmet for any other purpose, such as grinding etc.
- x **DO NOT** use helmet unless you have been instructed in its use by a qualified person.
- x **DO NOT** open or tamper with the shade cartridge.
- x **DO NOT** get the helmet wet or use in damp or wet locations.
- x **DO NOT** leave work place with helmet in lowered position, as bright light source may darken cartridge unexpectedly.
- x **DO NOT** place the helmet on a hot surface.
- x **DO NOT** use helmet without front cover lens fitted. To do so will invalidate your warranty.
- ✓ Clean helmet (see section 5.5) and store the helmet in a safe, dry, childproof location.
- WARNING!** The materials of the helmet may, when coming into contact with the wearers skin, cause an allergic reaction to susceptible individuals.
- WARNING!** Before welding always inspect the cartridge filter to ensure that it is not damaged. To test the filter prior to welding, direct the front of the cartridge filter to a bright light source which will cause the lens to darken. Then using your hand rapidly cover and uncover the sensor. The filter should lighten momentarily then return to a dark state.
- WARNING! DO NOT use the helmet if damaged or you suspect it may be faulty. (Contact Sealey dealer).**
- ▲ **DANGER! DO NOT USE if, at any time, the face plate in the cartridge FAILS to darken when exposed to a welding spark. Remove cartridge and return to your Sealey dealer for checking.**
Continued use of the product knowing that the auto darkening feature is NOT FUNCTIONING may DAMAGE YOUR EYES and CAUSE BLINDNESS.



2. INTRODUCTION

High quality shade 11 lens with large viewing area manufactured and tested to BSEN379. Fully automatic switching from light to dark on striking arc. Fitted with solar power panel - no batteries required. Deluxe contoured helmet design approved to BSEN175 gives full neck protection and protects lens from scratching when helmet is laid down. Comfortable headband and non-slip quick release ratchet mechanism. Suitable for MIG and arc welding.

3. SPECIFICATION

Viewing Area 97 x 47.5mm (3.82" x 1.87")
 Power Supply Solar cells
 Power On/Off Fully Automatic
 Arc Sensor 2
 Shade Inactive 3
 Shade Active 11
 UV/IR Protection. Up to Shade 16 at all times
 Switching Time 0.04ms
 Operating Temperature. -10°C to 70°C (14°F to 158°F)
 Storage Temperature . . -20°C to 70°C (-4°F to 158°F)
 Total Weight 430g

PWH199 Issue No: 1 - 22/04/08

4. INSTRUCTIONS FOR USE

- ❑ **WARNING!** Before using the helmet for welding ensure you have read and understood the safety instructions in Section 1.
- 4.1 The helmet comes ready assembled but before it can be used it must be adjusted to fit the user properly.
- 4.2 **ADJUSTING THE FIT OF THE HELMET.**
The overall circumference of the headband can be made larger or smaller by pushing in and rotating the knob on the back of the headband (See adjustment 'A' in fig.1). This can be done whilst wearing the helmet and allows just the right tension to be set to keep the helmet firmly on the head without it being too tight.
- 4.3 If the headband is riding too high or too low on your head adjust the strap which passes over the top of your head. To do this release the end of the band by pushing the locking pip out of the hole in the band. Slide the two portions of the band to a greater or lesser width as required and push the locking pip through the nearest hole (See adjustment 'B' in fig.1).
- 4.4 Test the fit of the headband by lifting up and closing down the helmet a few times whilst wearing it. If the headband moves whilst tilting re-adjust it until it is stable.
- 4.5 **ADJUSTING DISTANCE BETWEEN HELMET & FACE.**
To adjust the distance between the helmet and your face in the down position loosen the tilt knobs (D) on either side of the helmet and slide it nearer to or further from your face. (See adjustment 'C' in fig.1) It is important that your eyes are each the same distance from the lens otherwise the darkening effect may appear uneven. Re-tighten the tilt knobs when adjustment is complete.

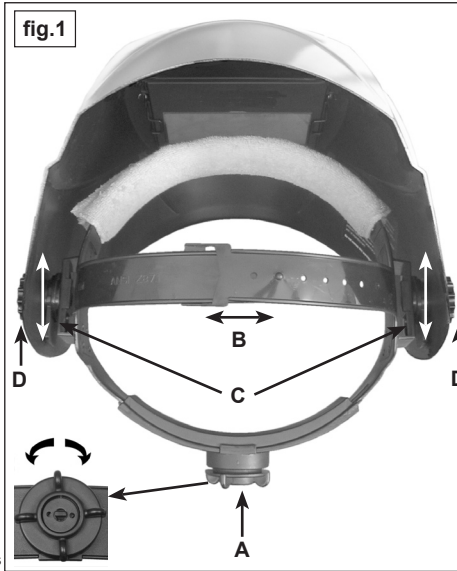

5. MAINTENANCE

- 5.1 **REPLACING FRONT COVER LENS.**
Place your finger or thumb into the recess at the bottom edge of the cover lens frame and flex the frame upwards until it releases from one edge. (See fig.2-C). Remove the protective film from the new lens. Hook the lens under the side retaining lip shown at 'A' in fig.2. Press on the other side of the frame to snap it under the edge shown at 'B' in fig.2.
- 5.2 **CHANGING THE SHADE CARTRIDGE.**
(See figs.3 & 4) The cartridge is retained by a wire loop clip as shown in fig.3. Release the front edge of the clip (fig.4-D) from its retaining lugs (fig.4-E) and hinge it upwards and out of the way. Lift the shade cartridge out of its frame.
- 5.3 **FITTING NEW CARTRIDGE.**
Take the new shade cartridge and place the cartridge into its retaining frame inside the helmet. Hinge down the wire loop clip and ensure that the front edge of the loop is properly retained under the retaining lugs as shown in fig.3.
- 5.4 **CLEANING.**
Clean helmet by wiping with a soft cloth. Clean cartridge surfaces regularly. Do not use strong cleaning solutions. Clean sensors and solar cells with methylated spirit and a clean cloth and wipe dry with a lint-free cloth.

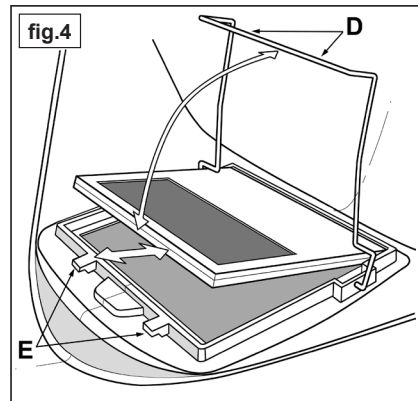
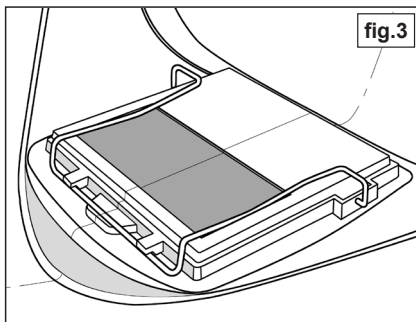
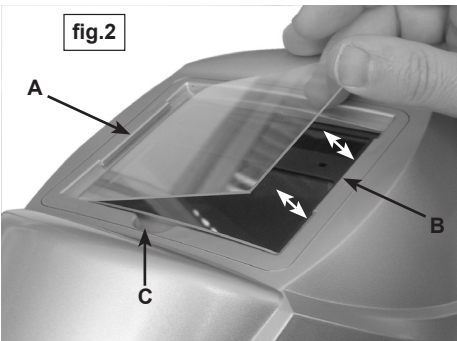

6. PROBLEM SOLVING

Problem	Cause	Solution
Irregular darkening or dimming.	The headband may have been unevenly set on the two sides of the helmet (unequal distances from the eyes to the shade cartridge).	Readjust the distance of the shade cartridge.
Shade cartridge does not darken or flickers.	The sensors are soiled or obstructed.	Clean.
	Front cover lens oiled or damaged.	Clean or replace.
	Welding current too low.	Adjust weld amps.
Poor vision.	Operative lenses and/or shade cartridge soiled.	Check, clean or replace.
	Insufficient background lighting.	Adjust light.
Slow response.	Operating temperature too low.	Do not use at temperatures below -10°C (14°F).
Welding helmet slips.	Headband adjustments incorrect.	Refer to section 4.

7. SHADE GUIDE & MARKINGS

Welding Process	ARC CURRENT (AMPS)																
	0.5	2.5	10	20	40	80	125	175	225	275	350	450					
SMAW				9	10		11		12		13		14				
MIG (Heavy)							10		11		12		13		14		
MIG (Light)							10		11		12		13		14	15	
TIG/GTAW				9	10		11		12		13		14				
MAG/CO2							10		11		12		13		14	15	
SAW									10		11		12		13	14	15
PAC											11		12		13		
PAW				8	9		10		11		12		13		14		15

SMAW - Shielded Metal Arc Welding

TIG/GTAW- Gas Tungsten Arc Welding

MIG (Light)- MIG on Light Alloys

MIG (Heavy)- MIG on Heavy Metals

PAW- Plasma Arc Welding

PAC- Plasma Arc Cutting

SAW- Shielded Semi-Automatic Arc Welding

MAG/CO2- Metal Active Gas

Meaning of the markings on the filter:

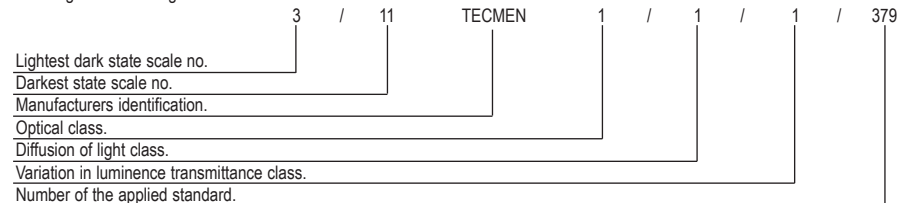

Meaning of the markings on the helmet:

EN 175
CE

= Number of the applied standard
= CE Mark