

INSTRUCTIONS FOR:
SYNERGIC PULSE MIG WELDER

MODEL: **PULSEMIG225.V2**





INSTRUCTIONS FOR : SYNERGIC PULSE MIG WELDER

MODEL : **PULSEMIG225.V2**

Thank you for purchasing a Sealey Welder. Manufactured to a high standard this product will, if used according to these instructions and properly maintained, give you years of trouble free performance.



IMPORTANT: BEFORE USING THIS PRODUCT, PLEASE READ THE INSTRUCTIONS CAREFULLY. MAKE CAREFUL NOTE OF SAFETY INSTRUCTIONS, WARNINGS AND CAUTIONS. THIS PRODUCT SHOULD ONLY BE USED FOR ITS INTENDED PURPOSE. FAILURE TO DO SO MAY CAUSE DAMAGE AND/OR PERSONAL INJURY AND WILL INVALIDATE THE WARRANTY. RETAIN THESE INSTRUCTIONS FOR FUTURE USE.

1. SAFETY INSTRUCTIONS

1.1. ELECTRICAL SAFETY

- WARNING!** It is the responsibility of the owner and the operator to read, understand and comply with the following:
 - You must check all electrical products, before use, to ensure that they are safe. You must inspect power cables, plugs, sockets and any other connectors for wear or damage. You must ensure that the risk of electric shock is minimised by the installation of appropriate safety devices. A Residual Current Circuit Breaker (RCCB) should be incorporated in the main distribution board. We also recommend that a Residual Current Device (RCD) is used. It is particularly important to use an RCD with portable products that are plugged into a supply which is not protected by an RCCB. If in any doubt consult a qualified electrician. You may obtain a Residual Current Device by contacting your Sealey dealer. You must also read and understand the following instructions concerning electrical safety.
- 1.1.1. **The Electricity at Work Act 1989** requires that all portable electrical appliances, if used on business premises, are tested by a qualified electrician, using a Portable Appliance Tester (PAT), at least once a year.
- 1.1.2. **The Health & Safety at Work Act 1974** makes owners of electrical appliances responsible for the safe condition of those appliances and the safety of the appliance operators. **If in any doubt about electrical safety, contact a qualified electrician.**
- 1.1.3. Ensure that the insulation on all cables and on the appliance is safe before connecting it to the power supply. See 1.1.1. and 1.1.2. and use a Portable Appliance Tester.
- 1.1.4. Ensure that cables are always protected against short circuit and overload.
- 1.1.5. Regularly inspect power supply cables and plugs for wear or damage and check all connections to ensure that none is loose.
- 1.1.6. **Important:** Ensure that the voltage marked on the appliance matches the power supply to be used and that the plug is fitted with the correct fuse - see fuse rating at right.
- 1.1.7. **DO NOT** pull or carry the appliance by the power cable.
- 1.1.8. **DO NOT** pull the plug from the socket by the cable.
- 1.1.9. **DO NOT** use worn or damaged cables, plugs or connectors. Immediately have any faulty item repaired or replaced by a qualified electrician.
- 1.1.10. **DO NOT** use this product with a cable extension reel.
- 1.1.11. Products which require more than 13 amps are supplied without a plug.
THE PULSEMIG225 IS REQUIRED TO BE CONNECTED TO A 30AMP SUPPLY. WE RECOMMEND THAT YOU DISCUSS THE INSTALLATION OF AN INDUSTRIAL ROUND PIN PLUG AND SOCKET WITH YOUR ELECTRICIAN.
- WARNING!** Be very cautious if using a diesel generator. The generator must be stable with regard to frequency (H3), voltage and wave form. The output must be higher than the absorbed power (kW) of the inverter. The diesel generator must also be self regulating.
Use of a generator without a regulator may be dangerous and will invalidate your inverter warranty.

FUSE RATING 30 AMP

1.2 GENERAL SAFETY

The operator should be properly trained to use the welder safely and should be informed about the risks relating to MIG and arc welding procedures, the associated protection measures and emergency procedures. (Refer also to the "IEC TECHNICAL SPECIFICATION or CLC/TS 62081: INSTALLATION AND USE OF EQUIPMENT FOR ARC WELDING")

- ▲ **DANGER!** *Unplug the welder from the mains power supply before performing maintenance or service.*
- ✓ Keep the welder and cables in good working order and condition. *Take immediate action to repair or replace damaged parts.*
- ✓ Use genuine parts and accessories only. *Unapproved parts may be dangerous and will invalidate the warranty.*
- ✓ When MIG/MAG welding use an air hose to regularly blow out any dirt from the liner and keep the welder clean for best and safest performance.
- ✓ When MIG/MAG welding check and spray the gas cup and contact tip regularly with anti-spatter spray available from your Sealey dealer.
- ✓ Locate welder in a suitable working area. Ensure area has adequate ventilation as welding fumes are harmful.
- ✓ Keep work area clean, tidy and free from unrelated materials. Also ensure the work area has adequate lighting, and that a fire extinguisher is at hand.
- WARNING: always use a welding helmet or mask to protect your eyes.**
Use special fire resistant protective clothing and do not allow the skin to be exposed to the ultraviolet and infrared rays produced by the arc. Other people in the vicinity of the arc should be protected by shields of non-reflecting welding curtains.
The operator should be adequately insulated from the electrode, the workpiece and any accessible earthed metal parts in the vicinity by the wearing of safety shoes and welding gauntlets plus the aforementioned safety clothing.
Where necessary the operator should work on insulating mats or on an insulated safety platform in elevated positions.
- ✓ Remove ill fitting clothing, remove ties, watches, rings, and other loose jewellery, and contain long hair.
- ✓ Ensure the workpiece is correctly secured before operating the welder.
- ✓ Avoid unintentional contact with workpiece. Accidental or uncontrolled use of the torch may be dangerous and will wear the nozzle.
- ✓ Keep non essential persons away from the working area. Any persons working within the area must use protective head shield and gloves.
- ✓ Stand correctly keeping a good footing and balance. Ensure the floor is not slippery, and wear non-slip shoes.
- x **DO NOT** operate the welder if it or its cables are damaged and DO NOT attempt to fit any unapproved torches, components, or parts to the welder unit.
- x **DO NOT** get welder wet or use in damp or wet locations or areas where there is condensation.
- ▲ **DANGER! DO NOT weld near inflammable materials, solids, liquids, or gases, and DO NOT weld containers or pipes which have held flammable materials or gases, liquids or solids. Avoid operating on materials cleaned with chlorinated solvents or near such solvents.**
- x **DO NOT** touch any live metal parts of the torch or electrode while the machine is switched on.
- x **DO NOT** weld on any containers which are under pressure.
- x **DO NOT** pull the welder by the cable, or the torch, and DO NOT bend or strain cables, protect from sharp or abrasive items, and DO NOT stand on cables or leads. Protect from heat. Long lengths of slack must be gathered and neatly coiled. DO NOT place cables where they endanger others.
- x **DO NOT** touch the torch or workpiece immediately after welding as they will be very hot. Allow to cool.
- x **DO NOT** operate welder while under the influence of drugs, alcohol or intoxicating medication, or if fatigued.
- ✓ When not in use store the welder in a safe, dry, childproof area.

- x **DO NOT** operate welder in damp or wet places and do not weld in the rain.
 - ✓ The welding machine should be placed on a horizontal surface that is capable of supporting the weight. If placed on an incline or uneven floor there is a danger of overturning.
 - x **DO NOT** use the welder for any work other than that for which it was designed (e.g. Do not attempt to de-ice mains water pipes).
 - ✓ Provide adequate ventilation or facilities for the removal of welding fumes from near the arc. The risk should be assessed by a Health and Safety professional in relation to the exposure limits for the welding fumes, which will depend on their composition, concentration and the exposure time.
- VOLTAGE BETWEEN ELECTRODE HOLDERS OR TORCHES.**
- x Working with more than one welding machine on a single piece or on pieces that are connected electrically may generate a dangerous amount of no-load voltage between the two electrode holders or torches, the value of which may reach double the allowed limit. Measuring instruments should be used to determine the existence of a risk and suitable precautions taken as detailed in section 5.9 of the IEC TECHNICAL SPECIFICATION OF CLC/TS 62081.
- 1.3 ELECTROMAGNETIC INTERFERENCE** The electromagnetic fields generated by the welding process may interfere with the operation of electrical and electronic equipment. Users of vital electronic and electrical devices such as pacemakers and respirators are advised not to remain in the vicinity of an operating welding machine. If in doubt seek medical advice before entering a welding area. Users of such devices should not operate the welding machine. This welder complies with the requirements of the technical standard for the use of this type of product, only and exclusively in industrial environments and for professional purposes. It is not guaranteed to meet electronic compatibility requirements in the home.
- 1.4 GAS SAFETY** Store gas cylinders in a vertical position only and ensure the storage area is correctly secured.
- x **DO NOT** store gas cylinders in areas where temperature exceeds 50°C. DO NOT use direct heat on a cylinder. Always keep gas cylinders cool.
 - x **DO NOT** attempt to repair or modify any part of a gas cylinder or valve, and DO NOT puncture or damage a cylinder.
 - x **DO NOT** obscure or remove any official labels from a cylinder. Always check the gas identity before use. Avoid getting gas cylinders oily or greasy.
 - x **DO NOT** try to lift or handle cylinder by its cap, guard or valve. Always keep caps and guards in place and close valve when not in use.
- The gas cylinder is heavy, use mechanical lifting equipment. Ensure the cylinder is correctly situated on the welder base stand and secured with chain.
- 1.5 RISK ASSESSMENT** Where welding is unavoidable in awkward situations such as in confined spaces, in environments with increased risk of electric shock, or in the presence of inflammable or explosive materials, a risk assessment must be carried out by an experienced and qualified expert professional in consultation with providers of emergency services to ensure that operations are carried out in the safest possible way.

2. DESCRIPTION & SPECIFICATION

- 2.1 DESCRIPTION** Microprocessor controlled, single phase, fan cooled power supply for MIG/MAG, TIG, MMA electrode, flux and arc welding plus brazing applications. Synergic operation gives efficient welding control and is particularly useful when welding aluminium, galvanised sheets, high strength steel and stainless steel. LED power read-out with push-button programming in conjunction with an encoder knob. The unit features regulation of post-gas and current down-slope time as well as control of AC balance and arc force. When TIG welding, lift start for reduced HF emissions can be selected. Ten Synergic welding programmes and capacity to store 20 further personalized programmes. Includes remote control connection for foot pedal or hand control.
- 2.2 SPECIFICATION**
- | | |
|--------------------------|---------------|
| Power Output: | 5-200 A |
| Duty Cycle: | 60% @ 160 A |
| Electrode Capacity:..... | Ø1.6 - 4.0 mm |
| Absorbed Power: | 6.0 kW |
| Mains Voltage: | 230V -1ph |
| Insulation Class: | H |
| Protection:..... | IP23 |
| Weight: | 24 kg |
- 2.3 OPTIONAL ACCESSORIES**
- | | |
|-----------------------------------|-------------------------|
| Arc Accessory Kit | INV/25 |
| TIG Torch | 120.742058 |
| Aluminium MIG Accessory Kit | 120.802279 |
| Foot Pedal | INV/TIG/5 |
| Current Control | INV/TIG/7 |
| Trolley | 120.803051 |
| Spool-on-gun Torches. | MIG/SGT15 & MIG/ST15/12 |

3. WELDING CAPABILITY

The PULSEMIG225 has the capability to perform the three main welding processes.

MIG/MAG-FLUX The welder is suitable for MIG welding of aluminium and its alloys, MIG brazing is typically carried out on galvanised plate and MAG welding on carbon, low alloy and stainless steels. It is also possible to Flux weld with tubular wire, without protective gas (self shielding) by adjusting the torch polarity according to the instructions given by the wire manufacturer.

MIG welding of aluminium and its alloys should be carried out using tubular wire with a composition that is compatible with the material being welded and pure Ar (99.9%) protective gas.

MIG Brazing can be carried out, typically on galvanised plate, using tubular wire in copper alloy (e.g. copper silicon or copper aluminium) with pure Ar (99.9%) protective gas.

MAG welding of carbon and low alloy steel should be carried out using flux core or tubular wire with a composition that is compatible with the material being welded and CO₂ and Ar/CO₂ or Ar/CO₂/O₂ mixtures as the protective gas (Ar normally >80%).

For welding stainless steel Ar/O₂ or Ar/CO₂ gas mixtures are normally used (Ar normally >98%).

TIG The welder is suitable for TIG welding in direct current (DC) with lift arc strike, and is suitable for use with all steels (carbon, low and high alloys) and heavy metals (copper, nickel, titanium and their alloys) with pure Ar (99.9%) protective gas or, for particular applications, Argon/Helium mixtures.

MMA The welding machine is also suitable for MMA electrode welding in direct current (DC) with all types of coated electrodes.

4. PREPARING INVERTER FOR USE

4.1 WELDING CABLE CONNECTION

- 4.1.1 The torch cable is supplied ready assembled but it may be necessary for you to assemble the work clamp cable. Attach the work clamp to one end of the cable as shown in fig.2.

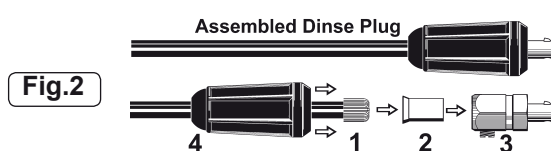
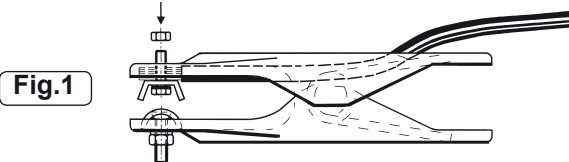

To connect the Dinse Plug as shown in fig.2 first thread the cable through the outer cover of the plug (see fig.2 - 4). Now remove 20mm of insulation sheath from the end of the cable and fold back the copper wire all around the outside of the sheath (1). Push the cable end into the copper sleeve (2) so that the folded back wire makes good contact with the inside of the sleeve. Push the copper sleeve into the brass plug body (3) and tighten the large grub screw until the cable is firmly held. Now slide the outer plug cover up the cable and press the brass body into it as Shown in fig.2.

4.2 CONNECTION TO THE MAINS POWER SUPPLY

- 4.2.1 Before making any electrical connections, ensure that the mains voltage and frequency of the supply matches the electrical specification of the welder as stated on the welder's rating plate.
- 4.2.2 The welder must only be connected to a power supply system with the neutral conductor connected to earth.
- 4.2.3 Refer to the section on electrical safety at the start of these instructions for information on the correct connection of the mains power plug.

5. CONTROL PANEL

- 5.1 **The PULSEMIG225** is a microprocessor controlled single phase welding machine with an integrated wire feed unit. The machine can be used for high quality welding in both continuous MIG/MAG/FLUX welding and pulsed MIG/MAG (in Synergic mode). The machine will also perform MMA electrode welding and TIG-DC lift welding. The wire feeder is equipped with a two roller motorised wire puller unit with independent adjustment of pulling pressure. The machine can also be used with a spool gun torch used for welding aluminium and steel when the power source and piece to be welded are far apart. The digital control panel is integrated with the microprocessor adjustment board and with this user interface it is possible to set and adjust the operating parameters, select previously stored programs and view parameter status and values on the display.
- 5.1.1 **Synergic mode.** In synergic mode, when one parameter is selected for adjustment, the microprocessor intelligently alters other related welding parameters appropriate for the selected welding process thus allowing optimum settings for all conditions. For example, in continuous MIG welding in synergic mode, if the wire speed is altered the voltage is automatically modified as well. In pulsed MIG welding, alterations to the current will result in automatic adjustment of voltage, wire speed, minimum pulse current, maximum pulse current, pulse current and pulse times in order to get the best working conditions.
- 5.1.2 **Memory allocation.** There are 30 memory locations stored within the machine. All memory locations are factory set to the following default parameters
Wire Fe0.8; wire speed 3m/min; Voltage 20V; arc correction 0.
10 programs are intended for continuous MIG welding in synergic mode.
10 programs are intended for continuous MIG welding out of synergic mode.
10 programs are intended for pulsed MIG welding in synergic mode.
The user can then modify any default program he chooses and when a useful combination of parameters has been found for a specific welding purpose this combination can be stored and recalled for use at a later date.
- 5.2 **SELECTION OF WELDING PARAMETERS (14a to 14i).**
- 5.2.1 The 9 welding parameters are situated in a strip across the centre of the panel immediately below the display and rotary knob. When a parameter is active the LED above it is illuminated. To select a particular parameters repeatedly press the twin arrow key to the left of the strip to step sequentially across to the parameter you require. The value to be adjusted will appear in the main display and the units of measurement will be indicated by one of the five LEDs situated directly above the display. Adjust the value by using the rotary control to the right of the display.

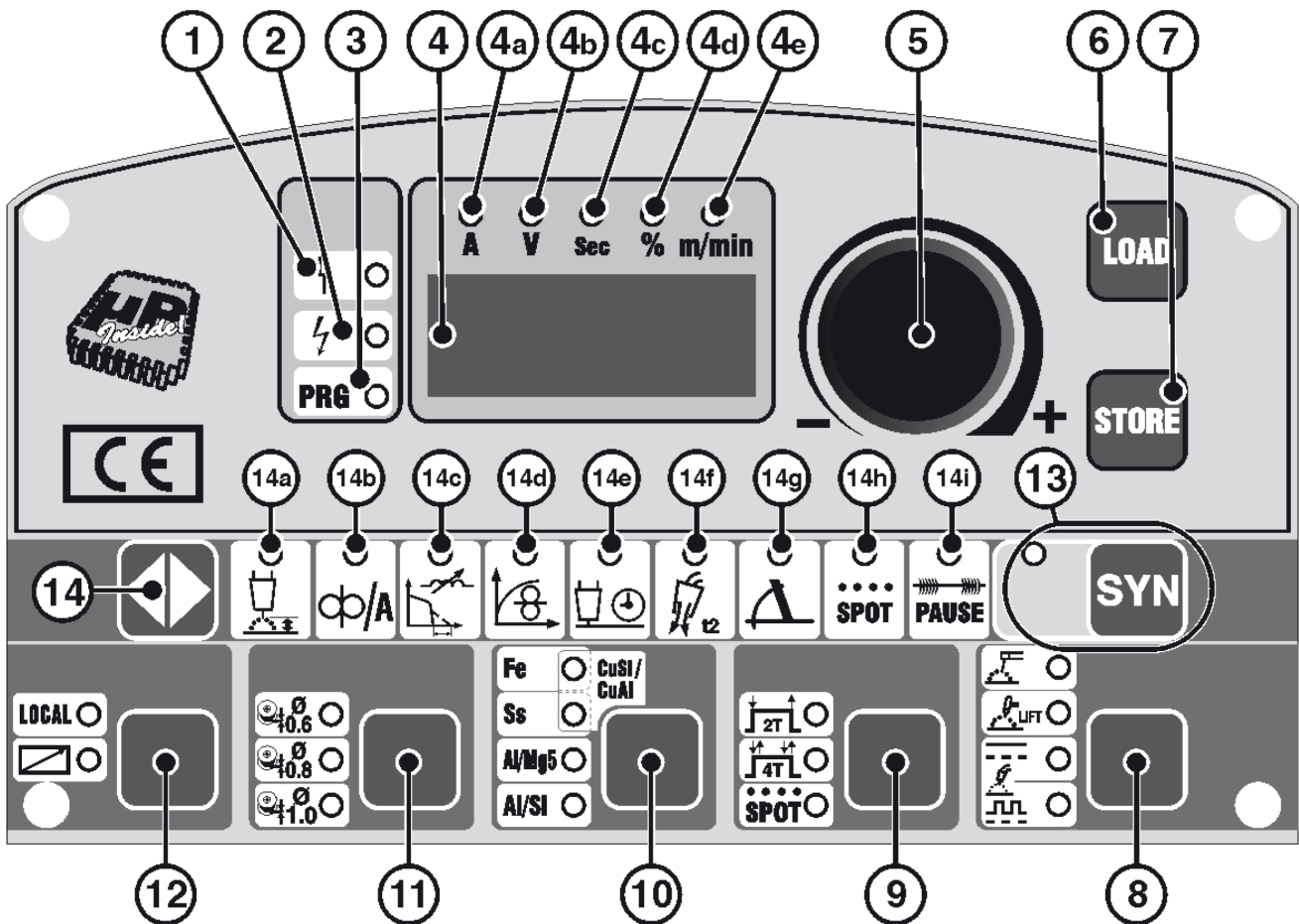

- 5.3 **SELECTION OF WELDING MODES (8 to 12).** Press each mode button repeatedly to cycle through the available choices until you reach the mode/function you require.
- 5.4 **DESCRIPTION OF CONTROL PANEL FUNCTIONS.**
- 1 **LED indicator alarm** (machine output is blocked). The machine will automatically be restored when the cause for the alarm has ceased. One of the following **alarm messages** may be displayed:
 "AL.1" An intervention of the primary circuit safety thermostat has happened due to the machine overheating (MIG pulse version only).
 "AL.2" one of the safety thermostats has triggered due to the machine overheating.
 "AL.3" Failure in the primary power supply: the power supply voltage is 15% above or below the rating plate value. **ATTENTION exceeding the higher voltage limit will seriously damage the machine.**
 "AL.4" Failure in the primary input: protection intervention due to mains undervoltage (MIG pulse version only).
 "AL.7" There has been an attempt at a MIG/MAG weld with a current that is too high for the power source.
 "AL.8" Failure in the MIG/MAG welding circuit (MIG pulse version only) **ATTENTION:** In this case it is necessary to switch the machine off and on again in order to reset it.
- 2 **LED indicating power present at output** (output on).
- 3 **LED indicates PROGRAMMING MODE.**
- 4 **3 DIGIT ALPHANUMERIC DISPLAY** can indicate the welding current in amps. The value shown is the set value if the welding machine is off load, while the actual value will be shown during operation. The LED indicators situated above the display indicate the following units of measurement.
 4a - Amps, 4b - Volts, 4c - Seconds, 4d - Percentage, 4e - Metres/minute
- 5 **ENCODER CONTROL KNOB** used to regulate the welding current and change the other specific settings.
- 6 **LOAD** Key for recalling customised welding programs
- 7 **STORE** Key for storing customised welding programs
- 8 **KEY FOR SELECTING WELDING MODE:**
 MMA electrode
 TIG - DC with LIFT strike.
 MIG/MAG/ FLUX in SHORT SPRAY ARC
 MIG/MAG in PULSE ARC
- 9 **KEY FOR SELECTING WELDING PROCESS:** When the machine is in MIG/MAG/FLUX mode it is possible to choose between 2-touch and 4-touch control or Spot Welding Timer.

- 10 KEY FOR SELECTING TYPE OF MATERIAL:** Sets the operating mode according to the material type or the welding mode. This facility is only available if Synergy is active (See 13).
- 11 KEY FOR SELECTING WIRE DIAMETER:** For a diameter of 1.2mm it is necessary to press the button until both LEDs corresponding to diameters 0.6 and 0.8mm light up together. This facility is only available if Synergy is active (See 13).
- 12 KEY FOR SELECTING REMOTE CONTROL:**
When LED 'LOCAL' is on the controls on the welder are enabled. When the other LED is on adjustments can only be carried out by the remote control attached.
A) Control with two potentiometers (INV/TIG/7): Replaces the rotary encoder operation and a related auxiliary function.
B) Pedal remote control (INV/TIG/4): Replaces the rotary encoder operation in TIG mode.
- 13 KEY FOR SELECTING SYNERGIC WELDING:** For setting Synergic operation in MIG/MAG mode.
WARNING! Even though the machine allows you to set every welding parameter freely, there are particular parameter combinations that may have no meaning from an electrical or welding point of view. The welder will not break down however, but it may not operate according to the incorrect settings.
- 14 KEY FOR SELECTING WELDING PARAMETERS:**
Pressing the key repeatedly will light up one of the LEDs from 14a to 14i associated with a specific parameter. The setting for the value of each activated parameter is made using the rotary encoder knob and the value will be shown on the display.
Note: Parameters that cannot be modified by the operator, depending on whether you are working with a synergy program or in manual mode, are automatically excluded from the selection; the corresponding LED will not light up.
- 14a Selects the welding voltage:** In MIG/MAG/FLUX it regulates the welding voltage in Volts or the arc correction for MIG/MAG only in Synergic Mode. During welding the power source output voltage is displayed.
- 14b Sets the wire feed rate or welding current :** In MIG/MAG/FLUX it regulates the wire feed rate in metres per minute. In MMA it regulates the welding current in Amps. During welding the power source output current is displayed.
- 14c Arc force or electronic reactance:** In MMA it regulates arc force or arc penetration. In MIG/MAG/FLUX the effect is similar but it is called electronic reactance.
- 14d Acceleration slope up:** In MIG/MAG/FLUX it regulates the gradient of the acceleration slope up of the wire feed motor.
- 14e Burn back time:** In MIG/MAG/FLUX it regulates the time interval elapsing between when the wire stops and the output current falls to zero.
- 14f Postgas:** In MIG/MAG/FLUX it regulates the post gas time in seconds
- 14g Slope down:** In MIG/MAG it regulates the slope down time. This facility is only available in Synergy mode.
- 14h Spot time:** In MIG/MAG/FLUX it regulates the welding current duration in SPOT welding.
- 14i Pause time in MIG/MAG/FLUX:** Regulates the duration of the pause between one spot weld and the next. When the setting is 0 secs, in order to carry out the next spot weld it is necessary to release the torch button and then press it again.

5.5 STORING AND RECALLING CUSTOMISED MIG/MAG PROGRAMS

The welder can be used to store customised programs relating to a set of valid parameters for a particular welding job. Each stored program can be recalled at any time so that the user finds the welder 'ready for use' for a specific job that has been previously optimised.

5.5.1 Storage procedure (STORE)

After adjusting the welding machine for optimal operation with a given type of weld proceed as follows:
Press button 7 "STORE" for 3 seconds. "St_" will appear on the display with a number between 1 and 9. Turn the rotary knob to choose the desired program number for storage. Press button 7 "STORE" again for 3 seconds. If the program has been successfully stored "YES" appears on the display. If the button is pressed for less than 3 seconds the program will not be stored and "NO" will appear on the display.

5.5.2 Loading procedure (LOAD)

Proceed as follows: Press button 6 "Load" for 3 seconds. "Ld_" will appear on the display with a number between 1 and 9. Turn the rotary knob to choose the number used to store the program that is now to be used again. Press button 6 "LOAD" again for 3 seconds. If the program has been successfully loaded "YES" appears on the display. If the button is pressed for less than 3 seconds the program will not be loaded and "NO" will appear on the display.

NOTE: During operations with the "Store" and "Load" keys the PRG LED (3) will be illuminated.

5.6 REMOTE CONTROLS (Optional.) Two types of remote control can be connected to the machine via the 14 pin connector situated on the front panel. Press button 12 in the bottom left hand corner of the front control panel to choose between local or remote control operation. When this option has been selected the knob on the main control panel becomes inoperative for those functions taken over by the remote control.

5.6.1 Remote control pedal (Model No. INV/TIG/5). When activated the pedal will control the main welding current. Also if spot welding has been selected or 2 step TIG welding the first movement of the pedal will initiate the striking of the arc.

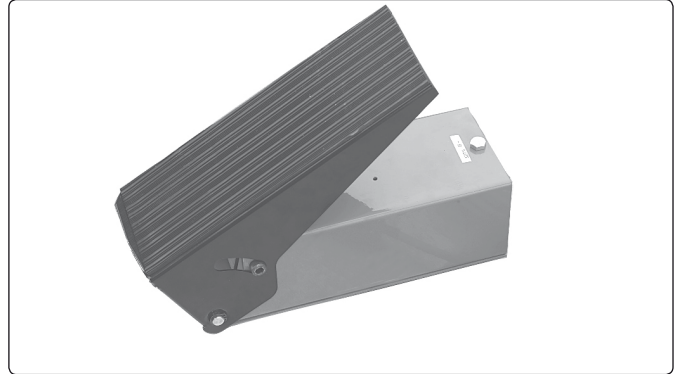

5.6.2 Remote control with two potentiometers (Model No. INV/TIG/7).

With the machine in remote mode, the knob furthest away from the cable entry, controls The main welding current. The second knob will control one other parameter depending on the active welding mode. (See table below.) The rotation of the second knob automatically selects the appropriate parameter and brings it up on the display.

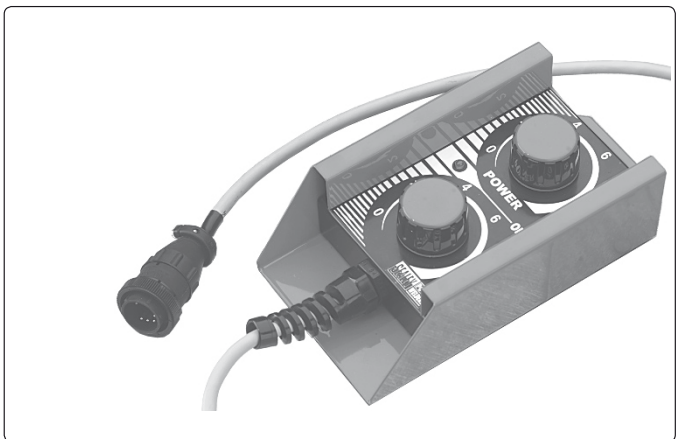

5.6.3 Welding mode.....Parameter for second knob.

MMA.....	Arc force. (Not displayed)
TIG	No function
MIG in Synergy	ARC correction
MIG out of Synergy	Voltage

6. MIG/MAG SET-UP AND PREPARATION

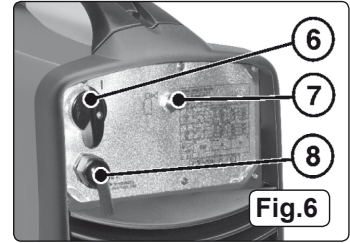
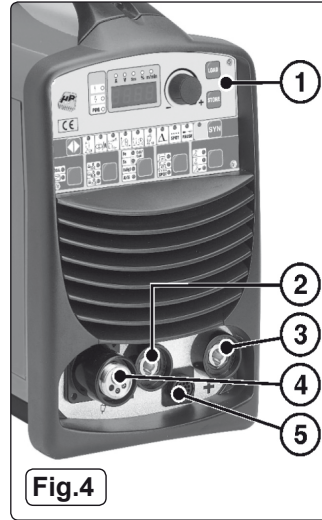
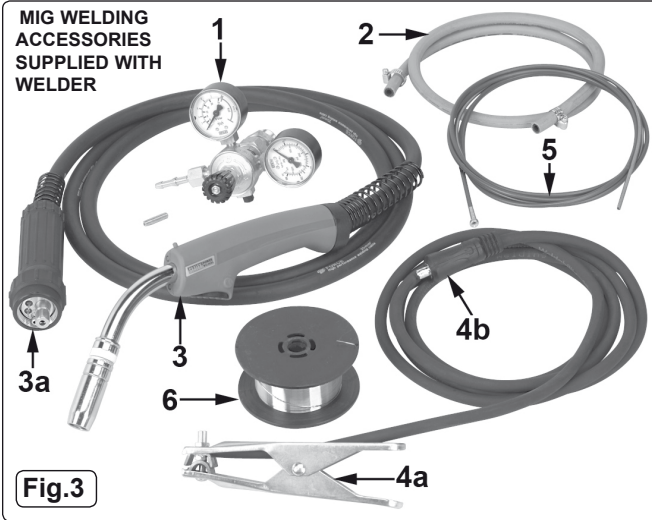

WARNING: BEFORE MAKING THE FOLLOWING CONNECTIONS MAKE SURE THAT THE WELDER IS SWITCHED OFF AND DISCONNECTED FROM THE MAINS POWER SUPPLY OUTLET.

6.1 CONNECTING THE GAS

As an optional extra a trolley is available which will hold both the gas bottle and the welder, Sealey Part No.120.803051 (see fig.7).

- 6.1.1 Screw the gas regulator (see fig.3.1) onto the gas bottle as shown in fig.5.
- 6.1.2 If using Argon or an Argon/CO₂ mixture fit the Bull Nose Adaptor, supplied, to the cylinder with a spanner and then attach the regulator to the adaptor.
- 6.1.3 Using the rubber tubing supplied (see fig.3-2) connect the regulator to the gas inlet on the back of the inverter (see fig.6-7). Hold the tubing securely in place on each connector by using the worm drive clamps supplied.
- 6.1.4 Open the regulator before opening the cylinder valve. Test for leaks.
- 6.1.5 Set the gas flow to suit the welding parameters required.
- 6.1.6 If necessary the gas flow can be adjusted during welding using the regulator knob.

6.2 CONNECTING THE WELDING CURRENT RETURN CABLE

- 6.2.1 Connect the disne plug (see fig.3 - 4b) to the negative socket at the base of the front panel (see fig.4.2). Connect the earth clamp to the piece to be welded or to the metal bench on which it rests as close as possible to the join to be made.

6.3 CONNECTING THE TORCH

- 6.3.1 Align the pins on the torch connector (see fig.3-3a) with the corresponding holes in the socket at the base of the front panel (see fig.4-4). Push in the connector and engage the locking ring with the thread in the socket and tighten it down as far as it will go.

6.4 FITTING A REEL OF WIRE Ensure the welder is unplugged from the mains power.

MAKE SURE THAT THE WIRE FEEDER ROLLERS, THE WIRE GUIDE HOSE AND THE CONTACT TIP OF THE TORCH MATCH THE DIAMETER AND TYPE OF WIRE TO BE USED AND MAKE SURE THEY ARE FITTED CORRECTLY. WHEN INSERTING AND THREADING THE WIRE **DO NOT WEAR PROTECTIVE GLOVES.**

- 6.4.1 Open the side of the unit, remove any spacer from the reelholder and push the reel of wire over the holder end springs and onto the holder (see Fig.8a) ensuring that the spool is rotating anti-clockwise with the wire drawing off the reel from the bottom towards the wire drive unit. The larger spools of wire have a guide hole which must be pushed over the plastic pin located at the back of the reel holder (See Fig.8b). When a larger reel has been located on this pin, push the appropriate spacer back onto the holder to keep reel engaged with the pin. The pin, in conjunction with the braking mechanism, will stop large reels from free wheeling around the holder.
- 6.4.2 Release the pressure counter roller by pulling the pressure adjustment knob forwards and downwards and move the upper roller away from the lower drive roller (See Fig.9a).
- 6.4.3 Make sure that the grooved drive roller has the correct size groove at the back of the roller in line with the wire drive path. If not, remove the roller and reverse it (See Fig.9b).
- 6.4.4 Free the end of the wire from the reel and remove the distorted end with a clean, burr free cut. Turn the reel anti-clockwise and thread the end of the wire into the wire guide infeed pushing it 50-100mm into the the wire guide of the torch fitting (See Fig.9c).
- 6.4.5 Reposition the counter roller making sure that the wire is correctly positioned in the groove of the lower roller. (See Fig.10) Adjust the pressure to an intermediate value.
- 6.4.6 Rotate the reel of wire anticlockwise whilst tightening the adjustment knob located at the centre of the spindle until a slight braking pressure can be felt on the reel. (See Fig.8b)

6.5 FEEDING WIRE THROUGH TO THE TORCH Ensure the welder is unplugged from the mains power.

- 6.5.1 Remove the nozzle from the torch as shown in fig.11 using a clockwise twist and pull action. Unscrew the contact tip.
- 6.5.2 Connect the welder to the mains power supply and set the voltage switch to the minimum.
- 6.5.3 Keep the torch cable as straight as possible and press the torch switch to feed wire through to the torch.
- 6.5.4 When wire has fed through, switch welder off, unplug from mains.
- 6.5.5 Replace contact tip and gas cup. Cut wire so that it is protruding 1/4" from the cup.

WARNING! During these operations the wire is live and subject to mechanical stress; therefore, if adequate precautions are not taken the wire could cause hazardous electric shock, injury and striking of electric arcs. Do not direct the torch tip towards parts of the body and keep the torch away from the gas bottle.

6.6 SETTING WIRE TENSION IMPORTANT: You must set the correct tension, too little or too much tension will cause problematic wire feed and result in poor welding.

- 6.6.1. Tension between rollers is checked by slowing down the wire between your fingers. If top feed roller skids the tension is correct. Use as low a tension as possible, too high a tension will deform wire and result in a blown fuse on the printed circuit board. Adjust tension by turning pressure knob as shown in fig.10.
- 6.7 **CLUTCH ADJUSTMENT** It is essential that the clutch is adjusted correctly. Once the wire is fed through the torch, switch on the machine and set the wire speed and voltage switch to maximum. Depress the torch switch and release quickly. If spool overruns it indicates that the clutch is too loose. Tighten the clutch (located in the centre of the wire spool holder (fig.8-b), and test the machine as above until the wire stops over running.

WARNING! DO NOT over tighten the clutch as this will cause wire feed problems.



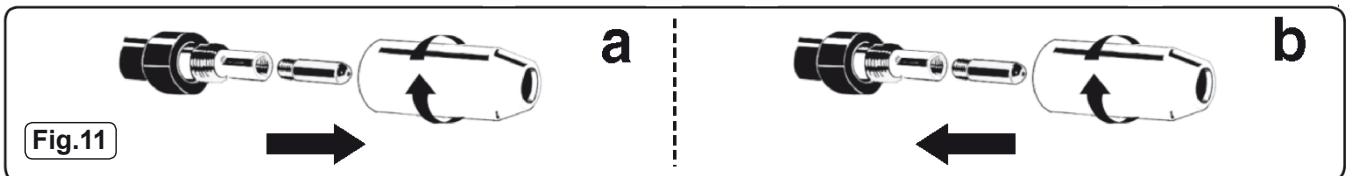
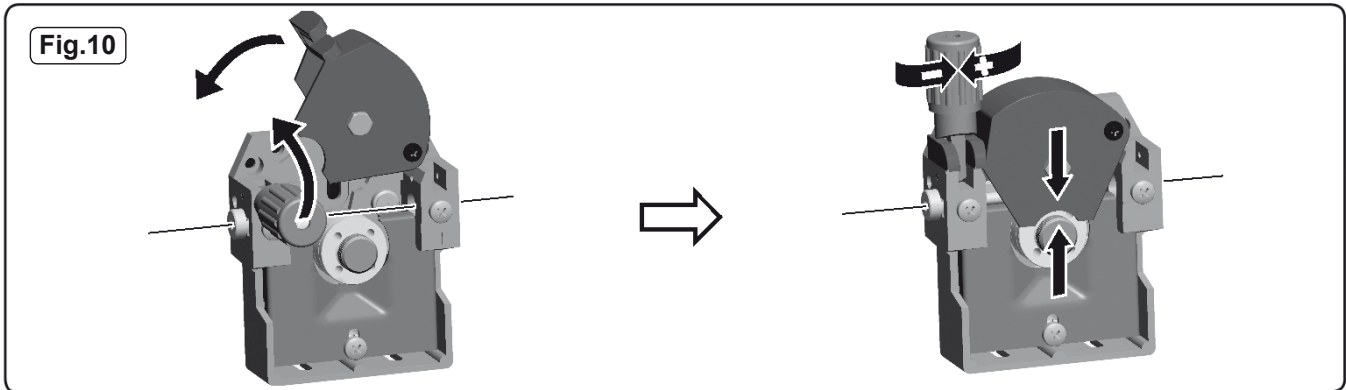
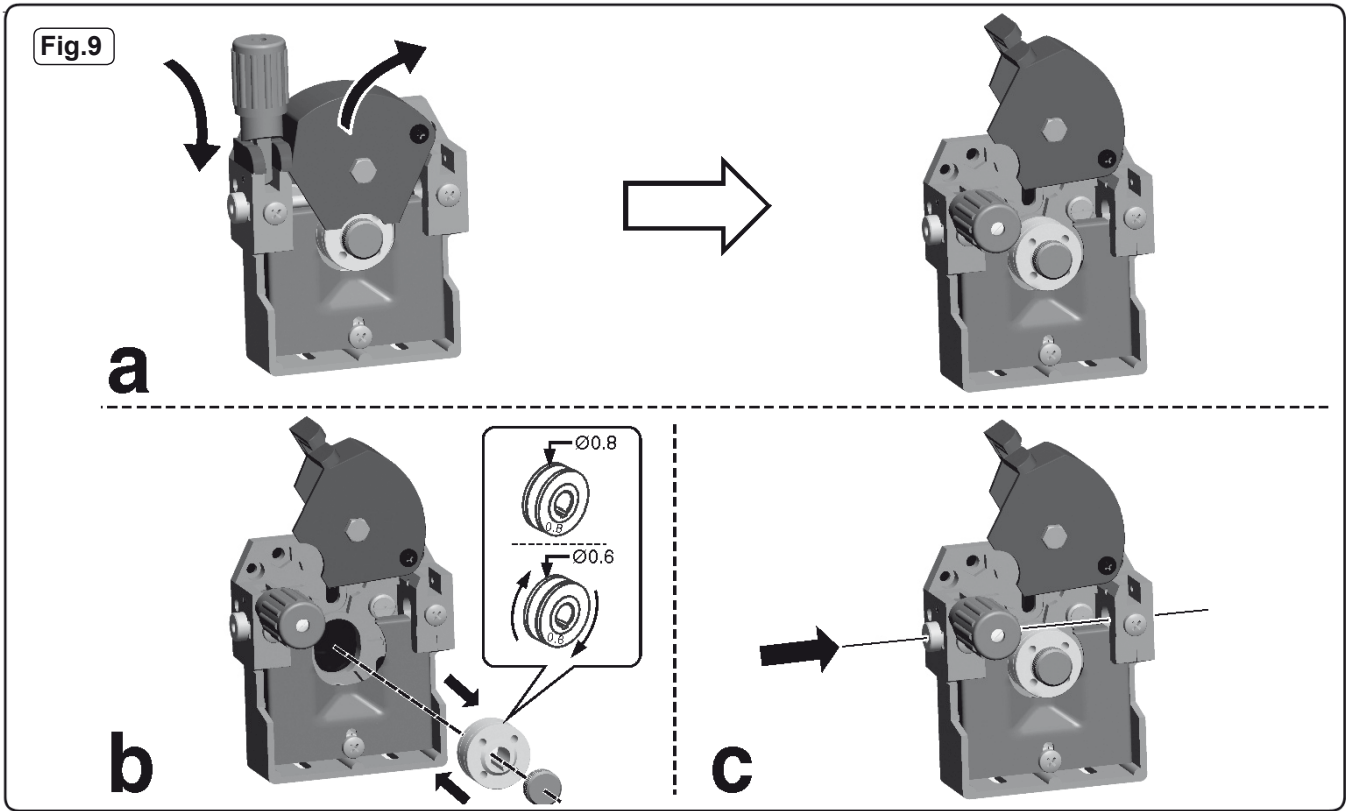
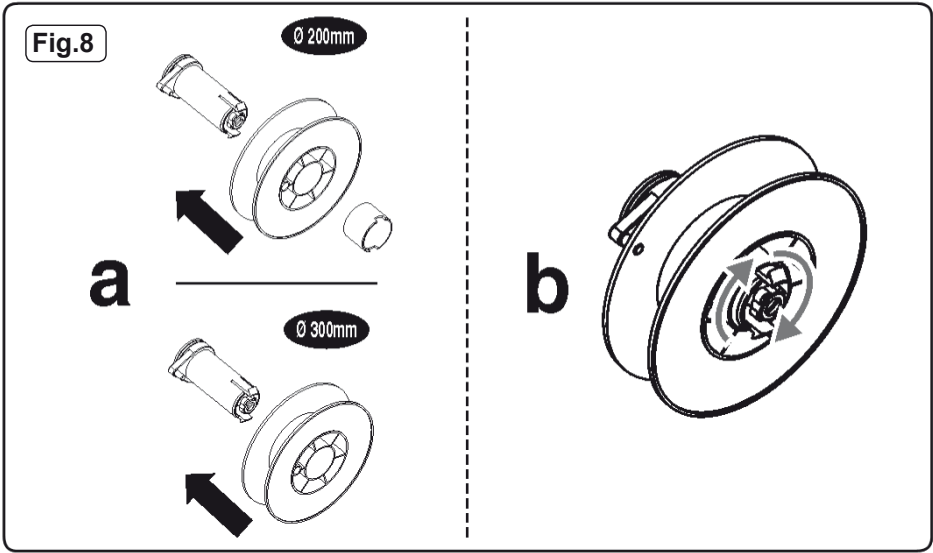

7. MIG/MAG WELDING PROCESS

IMPORTANT.

Should you have no welding experience, we recommend you seek training from an expert source to ensure your personal health and safety. You must familiarise yourself with welding applications and limitations, and specific potential hazards peculiar to welding. Good MIG welding may be achieved only with continued, supervised practice.

- 7.1 **MIG/MAG WELDING** (See fig.12). A spool of welding wire is placed on the spool holder and automatically fed through an insulated liner in the torch to its tip. The torch consist of a switch, liner, gas hose, and power cable. The switch activates the wire feed roller and the gas flow. Releasing the switch stops wire feed and gas flow. The weld current is transferred to the electrode (the wire) from the contact tip at the torch end. Wire speed must be adjusted according to power output. The higher the current the faster the wire speed. A gas cup fits over the contact tip to direct gas flow towards the weld ensuring the arc welding process is shielded from oxidising air contamination (fig.12). The shielding gas also assists heating of the weld.

7.2 PREPARATION FOR WELDING

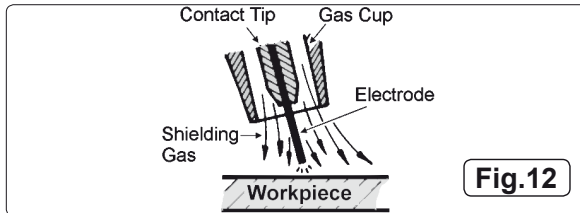

IMPORTANT: BEFORE YOU COMMENCE, MAKE SURE THE MACHINE IS SWITCHED OFF AT THE MAINS. IF WELDING A CAR, DISCONNECT THE BATTERY OR FIT AN ELECTRONIC CIRCUIT PROTECTOR. ENSURE YOU READ AND UNDERSTAND THE SAFETY INSTRUCTIONS IN CHAPTER 1.

- 7.2.1 Connect the earth lead as described in Section 6.2. To ensure a complete circuit, the earth lead clamp must be securely attached to the workpiece.
- Best connection is obtained by grinding the point of contact on the workpiece before connecting clamp to the workpiece.
 - The weld area must also be free of paint, rust, grease, etc.
 - If welding a vehicle, disconnect vehicle battery or fit an "Electronic Circuit Protector" to battery, (available from your Sealey dealer).
- 7.2.2 The wire feed rate parameter controls the speed of the wire feed. In principle, the lower the amperage the slower the wire speed.
- 7.3 **GAS TYPES AND THEIR USE** (See also Section 3 'Welding capability') Welding mild steel with CO₂ gas is appropriate for most welding tasks where spatter and high build up of weld do not pose a problem. To achieve a spatter free and flat weld however, you must use an Argon/CO₂ mixture.
- 7.4 **TORCH PUSH BUTTON CONTROL FUNCTIONS** The torch push button can be used to control the welding current in two different ways depending on your welding requirements. (Select one of the two options from the control panel. Refer to Key 9)
- 7.4.1 **Two step weld cycle.** In this mode the push button is pressed and held down to strike the arc and to continue welding. When the end of the weld is reached the push button is released and the arc is switched off. The 'post-gas' facility can be used in this mode if required.
- 7.4.2 **Four step weld cycle.** This mode allows you to complete long welds without having to continuously hold down the torch button. The push button is first held down which strikes the arc and then provides a current with a value which is 25% of the main current setting as long as the button continues to be held down. Once the push button is released the current rises to the welding current previously set and stays at this level even though the push button has been released. If the button is then pressed and held down again the current will decrease according to the current down slope setting until it is once again 25% of the preset current and remain there whilst the button is held. When the button is released the current is turned off and the post gas time begins. (If initiated.)
- 7.5 **COMMENCING WELDING**
- 7.5.1 Before carrying out difficult sections of welding, tests should be carried out on scrap pieces of metal. These tests should be carried out to find the best control settings in order to obtain the best welding possible. As a starting point use one of the factory default programs or adjust the values in manual mode (Synergy OFF). If the arc melts in drops and tends to go out, the speed of the wire should be increased or the welding current decreased. If, however, the wire hits the piece violently and causes material to be projected, the wire speed should be reduced. When a suitable set of parameters has been found for the task in hand these can be stored and recalled for future use.
- 7.5.2 It should be remembered that in order to obtain the best results, each type of wire is suited to a specific current and wire feed speed. Therefore, for difficult sections of welding and welding which requires a great deal of time, wires with different diameters should be tried so that the most suitable may be chosen.

- 7.5.3 **Turn on and adjust the protective gas** using the pressure regulator. Adjust to a flow rate of 5-7 l/min.
- 7.5.4 **NOTE: At the end of the job, remember to turn off the protective gas.**
- 7.5.5 **Switch the welder on and select a suitable program or set the parameters individually in manual mode.**
- 7.5.6 **Ensure that the earth clamp is in contact with the workpiece.**
- 7.5.7 **Press the torch button**, keeping the torch at a safe distance from the workpiece.
- 7.6 **WELDING ALUMINIUM.**
- 7.6.1 To weld aluminium you will need the MIG Aluminium Welding Kit (Fig.13) which includes a spool of aluminium wire, new contact tips and a new liner and drive roller specifically for the smooth running of aluminium. Alternatively the spool-on-gun type torches MIG/SGT15 & MIG/SGT15/12 can be used (See below) which have a minimum length wire feed path compared to a standard torch for maximum reliability.
- Gas types:** Argon gas or an Argon-Helium mixture.
- 7.7 **INSTALLING THE NEW LINER FOR ALUMINIUM**
- 7.7.1 Switch off the welder and unplug the torch connector.
- 7.7.2 Remove the nozzle from the torch as shown in fig.11 and unscrew the contact tip.

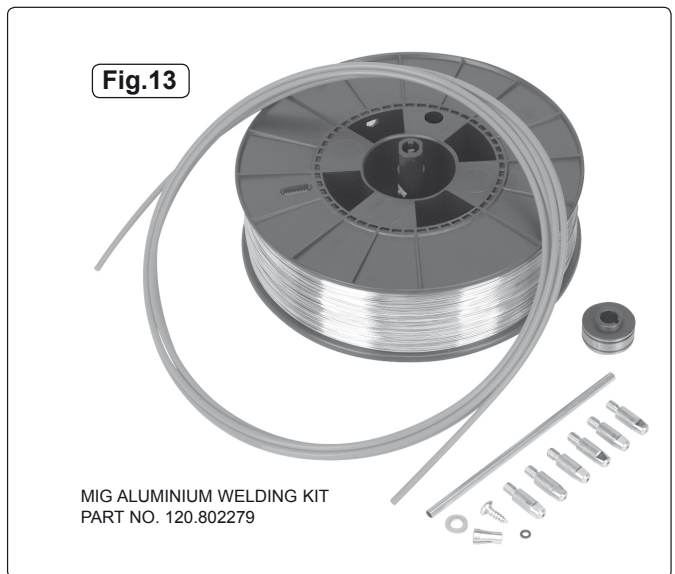

- 7.7.3 Unscrew the hose locking nut on the torch connector and pull out the old liner.
- 7.7.4 Insert the new hose into the cable torch duct and push it gently until it comes out of the torch head
- 7.7.5 Fit and tighten the contact tip for aluminium making sure that it comes into contact with the liner.
- 7.7.6 At the torch connector end of the hose, slide the brass nipple, 'O' ring and locking nut over and down the liner. Insert the nipple into the brass liner duct and, keeping slight pressure on the hose, tighten the hose locking nut.
- 7.7.7 Loosen the clamp screw on the wire feed unit and remove the brass capillary tube from the torch connector socket. Cut to length the steel pipe provided with the kit so that it is 2mm shorter than the brass capillary tube.
- 7.7.8 Insert the excess part of the hose into the torch connector socket and push in the torch connector and fully tighten the locking ring. Now mark the hose 1 to 2mm from the wire feed rollers. Remove the torch connector and trim the hose to length.
- 7.7.9 Slide the steel pipe over the liner protruding from the torch connector then slide the pipe and liner into the liner duct in the torch connector socket. Insert the torch connector and tighten the locking ring.
- 7.7.10 The liner should now be 1 to 2mm from the wire feed roller and fully supported by the steel pipe which encases it.
- 7.7.11 Reassemble the contact tip and nozzle to the torch.
- 7.8 **WELDING ALUMINIUM USING A SPOOL GUN**
- 7.8.1 The Spool Guns MIG/SGT15 & MIG/SGT 15/12 are specifically designed for welding aluminium and have an integral wire feed drive and a minimum length wire feed path compared to an ordinary torch, thus providing a consistently reliable way of welding aluminium. The gun is light in weight, well balanced and has an on-gun wire feed control for fine adjustments during the welding process.
- WARNING: BEFORE MAKING THE FOLLOWING CONNECTIONS MAKE SURE THAT THE WELDER IS SWITCHED OFF AND DISCONNECTED FROM THE MAINS POWER SUPPLY OUTLET.**

- 7.8.2 **SPOOL GUN CONNECTIONS.** The spool gun is fitted with a "Euro Connection" quick release connector. Line up the pins in the torch connector with appropriate holes on the front panel connector, push in and tighten the locking nut. The additional 'control' connector should be attached to the special socket between the two dinse sockets on the front panel. The ring that encloses the pins has several ribs around its outer face. Identify the thickest rib and present this to the socket in the 12 o'clock position. Push the plug home and tighten the locking nut. The welder will recognise the spool gun automatically.
- 7.8.3 **FITTING A REEL OF WIRE.** Ensure the welder is unplugged from the mains power. MAKE SURE THAT THE WIRE FEEDER ROLLERS, THE WIRE GUIDE HOSE AND THE CONTACT TIP OF THE TORCH MATCH THE DIAMETER AND TYPE OF WIRE TO BE USED AND MAKE SURE THEY ARE FITTED CORRECTLY. WHEN INSERTING AND THREADING THE WIRE **DO NOT WEAR PROTECTIVE GLOVES.**
- 7.8.3.1 Remove the reel cover by undoing the central knurled retaining nut. (See fig.14-1)
- 7.8.3.2 Position the reel of wire onto the central spindle.
- 7.8.3.3 Free the pressure counter roller and move it away from the lower roller. (See fig.14-2)
- 7.8.3.4 Free the end of the wire, cut off the distorted end with a clean cut leaving no burrs; turn the wheel anticlockwise and thread the end of the wire into the wire guide infeed, pushing it 50-100mm into the lance. (See fig.14-2)
- 7.8.3.5 Reposition the counter roller, adjusting the pressure to an intermediate value and make sure the wire is correctly positioned in the lower roller recess. (See fig.14-3)

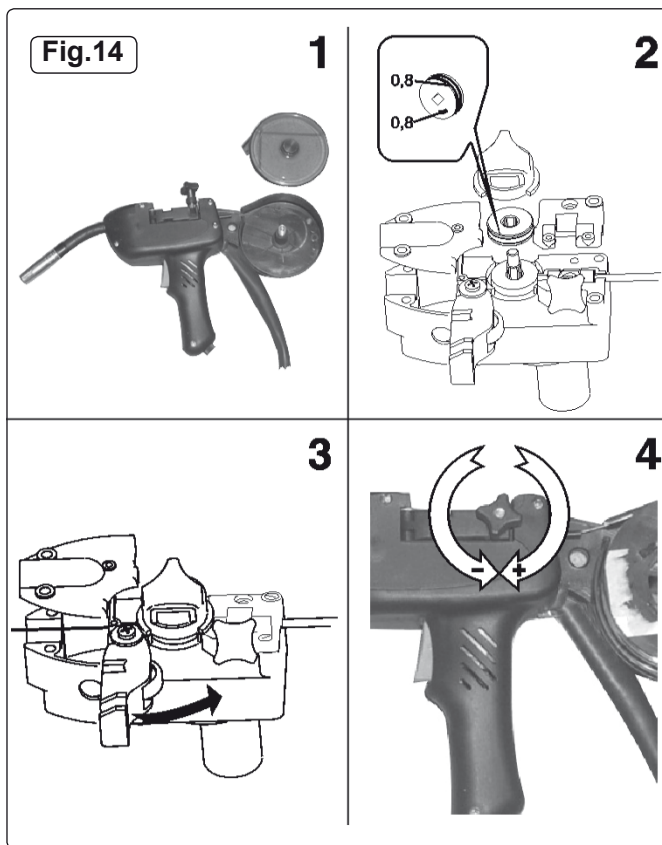

- 7.8.6 Switch on the welding machine by rotating the switch to the (I) symbol. Press the spool gun button and wait until the end of the wire runs through the complete wire guide hose. Release the torch button when 10 to 15cm of wire protrudes from the front of the torch. **WARNING! When testing the wire feed do not allow the wire to come into contact with the workpiece or earthing connection as this would inadvertently strike the arc causing potential injury. To avoid mechanical injury do not direct the wire at yourself or any other persons.**
- 7.8.7 Adjust the wire feed tension and clutch pressure if necessary. When the wire is feeding correctly turn off the power and disconnect the welder from the mains supply until it is required.
- 7.8.8 **CLUTCH ADJUSTMENT.** It is essential that the clutch is adjusted correctly. Depress the gun/torch switch and release it quickly. If the spool overruns it indicates that the clutch is too loose. At the end of the wire reel spindle is a knurled ring that adjusts the clutch pressure. When this ring is turned clockwise the flexible plastic tubing below it swells and grips the inside of the reel. Continue to tighten the clutch ring until a slight braking pressure is felt when the wire is pulled. Test again and re-adjust if necessary until the reel ceases to overrun. **DO NOT over tighten the clutch as this will cause wire feed problems.**

- 7.8.9 **SETTING WIRE TENSION.** *IMPORTANT: You must set the correct tension, too little or too much tension will cause problematic wire feed and result in poor welding.*
- 7.8.10 Tension between rollers is checked by slowing down the wire between your fingers. If top feed roller skids the tension is correct. Use as low a tension as possible, too high a tension will deform wire and result in a blown fuse on the printed circuit board. Adjust tension by turning knob shown in fig.14-4.

FOR FURTHER INFORMATION REFER TO THE INSTRUCTIONS PROVIDED WITH THE SPOOL GUN

8. FLUX WELDING (NO GAS)

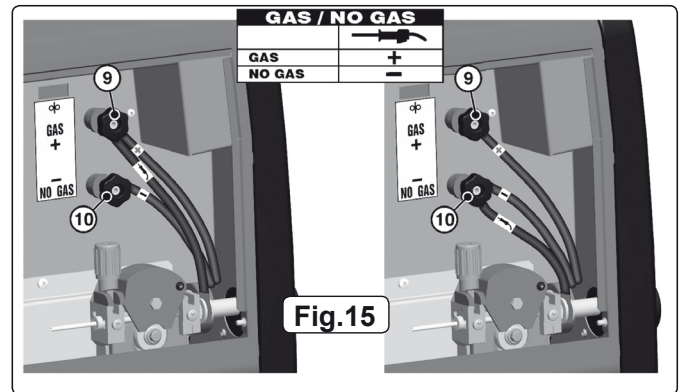

- 8.1 **FLUX WELDING.** It is possible to weld without protective gas by using a flux cored wire which is self shielding. The connections for the welding return cable and the torch are the same as those for MIG/MAG welding but it is necessary to change the voltage polarity in the reel compartment as shown on the label within the compartment. (See fig.15-9 &15-10)
- 8.2 **MIG/MAG/FLUX SPOT WELDING** (It is suggested that you do several tests with different settings before proceeding to the actual weld required.) Remove the gas cup and fit a spot welding gas cup.
- 8.2.1 Select the spot welding mode on the front panel and proceed to set the current value you require and the spot welding time up to 10 seconds.
- 8.2.3 Drill a small hole in the top workpiece. Push the spot gascup onto the material to be welded (fig.A). The castellations on the cup keep it the correct distance from the weld pool and allow you to push the two pieces being welded together. Press the torch trigger to commence welding. The wire will feed through during the allotted time and welding will stop automatically. A 'pause time' can be set between one spot weld and the next. (See Section 5 Key 14i). When the setting is 0 seconds, in order to carry out the next spot weld, it is necessary to release the torch button and then press it again.

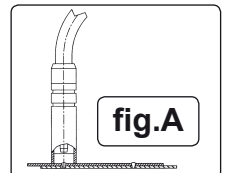

9. WIRE WELDING MODES

- 9.1 **SHORT ARC**
The melting of the electrode wire and the detachment of the drop is produced by repeated short circuits (up to 200 times per second) from the tip of the wire to the molten pool. See suitable settings for the most common materials below.
- Carbon and mild steels**
- Suitable wire diameter 0.8 to 1.6mm
 - Welding current range 40-210A
 - Arc voltage range 13 to 23V
 - Suitable gases CO₂, mix Ar/CO₂, Ar/CO₂/O₂
- Stainless steels**
- Suitable wire diameter 0.8 to 1.0mm
 - Welding current range 40-160A
 - Arc voltage range 14 to 20V
 - Suitable gases mix Ar/O₂, Ar/CO₂ (1-2%)
- Aluminium and alloys**
- Suitable wire diameter 0.8 to 1.6mm
 - Welding current range 75-160A
 - Arc voltage range 16 to 22V
 - Suitable gases Ar 99.9%
 - Wire stick out 5-12mm
- Generally, the contact tip should be flush with the nozzle or protrude slightly when using the thinnest wires and lowest arc voltages; the length of free wire (stick out) will normally be 5 to 12mm.
- Application:** Welding in all positions, on thin material or for the first pass in bevelled edges, with the advantage of limited heat transfer and highly controllable pool.
- Note:** Short arc transfer for welding aluminium and alloys should be used with great care (especially with wires of a diameter > 1mm) because the risk of melting defects may arise.

9.2 SPRAY ARC TRANSFER MODE

Higher voltages and currents than for 'short arc' are used here to achieve the melting of the wire. The wire tip does not come into contact with the molten pool; an arc forms from the tip and through it flows a stream of metallic droplets. These are produced by the continuous melting of the electrode wire without short circuits involved.

Carbon and mild steels

- Suitable wire diameter 0.8 to 1.6mm
- Welding current range 180-450A
- Arc voltage range 24 to 40V
- Suitable gases mix Ar/CO₂, Ar/CO₂/O₂

Stainless steels

- Suitable wire diameter 1.0 to 1.6mm
- Welding current range 140-390A
- Arc voltage range 22 to 32V
- Suitable gases mix Ar/O₂, Ar/CO₂ (1-2%)

Aluminium and alloys

- Suitable wire diameter 0.8 to 1.6mm
- Welding current range 120-360A
- Arc voltage range 24 to 30V
- Suitable gases Ar 99.9%

The contact tip should generally be 5-10mm inside the nozzle, the higher the arc voltage the further inside; the length of free wire (stick out) should normally be between 10-12mm. In Manual Mode, once the wire feed rate and arc voltage parameters have been selected correctly (i.e. with compatible values) the selected value of the reactance is immaterial.

Application: Horizontal welding with thicknesses of at least 3-4mm (very fluid pool); execution rate and deposit rate are very high (high heat transfer).

9.3 PULSE ARC TRANSFER MODE

This is a 'controlled' transfer situated in the 'Spray Arc' transfer area (modified spray arc) and therefore has the advantages of speedy melting and lack of projections, extending to significantly lower current values so as to satisfy many typical 'short arc' applications as well. Every current impulse corresponds to the separation of a single drop from the wire electrode; the phenomenon occurs with a frequency that is proportional to the wire feed rate with the variation rule related to the type and diameter of the wire itself (typical frequency values: 30-300Hz)

Carbon and mild steels

- Suitable wire diameter 0.8 to 1.6mm
- Welding current range 60-360A
- Arc voltage range 18 to 32V
- Suitable gases mix Ar/CO₂, Ar/CO₂/O₂ (CO₂ max 20%)

Stainless steels

- Suitable wire diameter 0.8 to 1.2
- Welding current range 50 - 230A
- Arc voltage range 17 to 26V
- Suitable gases mix Ar/O₂, Ar/CO₂ (1-2%)

Aluminium and alloys

- Suitable wire diameter 0.8 to 1.6mm
- Welding current range 40 - 320A
- Arc voltage range 17 to 28V
- Suitable gases Ar 99.9%

Normally the contact tip should be 5-10mm inside the nozzle, the higher the arc voltage, the further inside. The length of free wire (stick out) will normally be between 10 and 12 mm.

Application: "Horizontal" welding on medium to low thicknesses and on heat sensitive materials. Particularly suitable for welding light alloys (aluminium and its alloys), also on thicknesses below 3mm.

9.4 ADJUSTING THE WELDING PARAMETERS

9.4.1 **Shielding gas:** Shielding gas flow rate should be: Short arc 8-14l/min depending on welding current intensity and nozzle diameter.

9.4.2 **Welding current:** Welding current is determined for a given wire diameter by its own advancement speed. Remember that for a given current the wire advancement speed is inversely proportional to the diameter used. Approximate values for the current in manual welding mode for the most commonly used wires are shown in the table to the right.

9.4.3 **Arc Voltage:** Arc Voltage can be adjusted by the operator by turning the encoder knob; it adjusts itself to the chosen wire feed rate (current) according to the diameter of the wire being used and the type of protective gas, progressively according to the following relationship, which gives an average value: $U_2 = (14 + 0.05 \times I_2)$ where U_2 = arc voltage in volts and I_2 = welding current in amperes.

9.4.4 **Weld quality:** The quality of the weld is higher when less spatter is produced. This is determined principally by a correct balance of the welding parameters i.e. current, wire speed, wire diameter, arc voltage etc. as well as a correct choice of choke intakes. Furthermore, in order to avoid excessive spatter and faults on the weld seam the torch position should comply with the recommendations for direction and angle indicated in the diagram below. The weld speed (i.e. the advancement along the joint) is also a determining factor for the correct execution of the seam. This is particularly important for good penetration and shape of the seam.

VALUES FOR WELDING CURRENT MIG/MAG

WIRE DIAMETER	0,6	0,8	1	1,2
Carbon and mild steels				
SHORT ARC	30 + 90	40 + 170	50 + 190	70 + 200
SPRAY ARC	/	160 + 220	180 + 260	130 + 350
Stainless steel				
SHORT ARC	/	40 + 140	60 + 160	110 + 180
SPRAY ARC	/	/	140 + 230	180 + 280
Aluminium and alloys				
SHORT ARC	/	50 + 75	90 + 115	110 + 130
SPRAY ARC	/	80 + 150	120 + 210	125 + 250

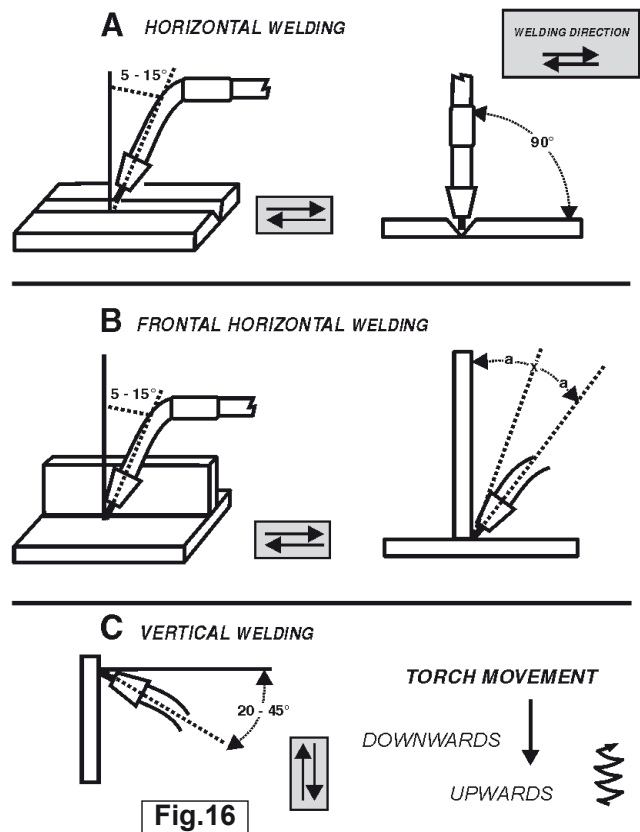

Fig.16

10. TIG WELDING SET-UP



To TIG weld you will need a TIG torch Model No 120.742058 (see fig.17). The other items shown in fig.17 you may already possess if you have also purchased a MIG/MAG welding kit. Any items you do not possess can be ordered using the part nos. shown above.

- 10.1 TIG Torch cable** Dinse plug (See fig.17) at end of the torch cable will be connected to the **negative socket (-)** on lower front panel (see fig.18-2).
- 10.2 Work clamp cable** Dinse plug at end of the clamp cable (See Fig.17) will be connected to the **positive socket (+)** on lower front panel (see fig.18-2)

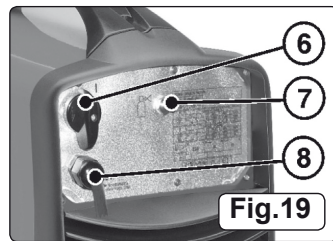
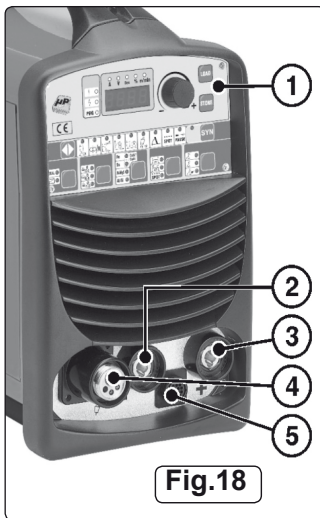

10.3 CONNECTING THE GAS

- 10.3.1** When using Argon gas fit the Bull Nose Adaptor (see fig.17-3) supplied, to the cylinder with a spanner.
- 10.3.2** Fit the gas regulator (see fig.17-4) onto the Bull Nose Adaptor. (see fig.20)
- 10.3.3** Connect the gas input pipe to the regulator and secure in place with a worm drive clip.
- 10.3.4** Open the regulator **before** opening the cylinder valve. Test for leaks.
- 10.3.5** Set the gas flow to suit the welding parameters required. See WELDING PARAMETER TABLE below for general guidance.
- 10.3.6** If necessary the gas flow can be adjusted during welding using the regulator knob.

	Electrode	mm	I ₂	mm	mm	Ar	mm	
		(mm)	(A)	(mm)	(mm)	(l/min)	(mm)	
TIG	STAINLESS	0.3 - 0.5	5 - 20	0.5	6.5	3	-	
		0.5 - 0.8	15 - 30	1	6.5	3	-	
		1	30 - 60	1	6.5	3 - 4	1	
		1.5	70 - 100	1.6	9.5	3 - 4	1.5	
		2	90 - 110	1.6	9.5	4	1.5 - 2.0	
		3	120 - 150	2.4	9.5	5	2 - 3	
DC	COPPER	0.3 - 0.8	20 - 30	0.5 - 1	6.5	4	-	
		1	80 - 100	1	9.5	6	1.5	
		1.5	100 - 140	1.6	9.5	8	1.5	
		2	130 - 160	1.6	9.5	8	1.5	

10.4 PREPARATION AND CHOICE OF ELECTRODE

For TIG-DC lift welding a **2% Ceriated Electrode (Grey)** should be chosen. This type of electrode is characterised by ease of starting, good arc stability, long life, high current capacity, and lack of radioactivity. In order to produce a good weld it is important to choose an electrode of the correct diameter for the current to be used. For a general guide to the settings to be used with particular diameters of electrodes please refer to the table above. The electrode will normally protrude from the ceramic nozzle by 2 to 3mm but in order to gain access to inaccessible areas such as internal corners the electrode can be made to protrude by up to 6mm. The chosen electrode should be sharpened axially on a grinding wheel as indicated in the diagram below. The tip should be perfectly concentric in order to avoid arc deviations. The condition of the electrode should be regularly inspected to maintain it in peak condition.

- 10.5 PREPARATION OF THE WORKPIECE** For a good weld it is important that the workpiece is thoroughly cleaned so that no oxides, oil, grease or solvents remain on the surface of the material.

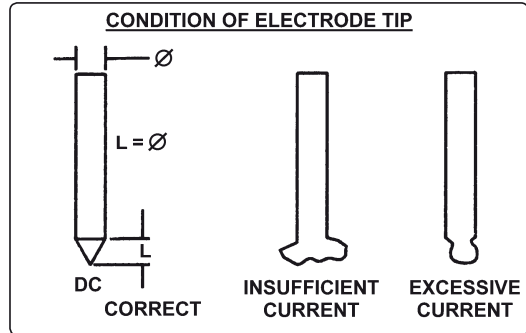

11. TIG WELDING PRINCIPLES & FEATURES

If you have no welding experience we recommend that you seek training from an expert source before using this equipment. Good TIG welding may only be achieved with continued supervised practice.

Before commencing welding read the safety instructions in Section 1.

- 11.1 TIG WELDING - GENERAL PRINCIPLES OF OPERATION** (For a concise explanation of the many facilities of the PULSEMIG225 refer to Section 5. Control Panel)

The TIG welding procedure uses the heat produced by an electric arc, struck and maintained between a Tungsten electrode and a workpiece to soften and fuse the workpiece metal, usually in conjunction with a suitable filler rod. The electrode is held in an insulated torch which transmits the welding current to the electrode. The torch also has a gas connection which allows inert Argon gas to be dispensed from a ceramic nozzle surrounding the electrode. This produces a shroud of gas around the welding process which protects the electrode and molten weld pool from oxidation.

12. TIG WELDING PROCEDURE

- WARNING!** Use welding head shield to protect eyes and avoid exposing skin to ultraviolet rays given off by electric arc. Wear safety welding gauntlets.
- If difficult welds are to be performed and the welding parameters are unknown, it is advisable to carry out several trial runs on test pieces in order to determine the right welding current and gas flow.*
- 12.1 SWITCH ON** the welder only when you are satisfied that the welder is correctly connected and the work to be done is fully prepared.
- Setting the controls.** (Load an appropriate program or set up the parameters from scratch.)
- 12.1.1** Select TIG-DC with lift strike. (See Section 5 Key 8)
- 12.1.2** Set the required gas flow using the knob on the gas regulator.
- 12.1.3** Set the welding current required.
- 12.2 STRIKING THE ARC (Lift strike)** Place the electrode tip onto the workpiece using gentle pressure. Lift the electrode 2 to 3mm from the workpiece with a delayed action thereby obtaining the striking of the arc. Initially the welder supplies only a base current which in a few moments increases to the set current. When the arc is established, form a molten pool on the workpiece, introduce the filler rod and proceed along the joint. When the arc is difficult to strike, despite the presence of gas and visible high frequency discharges it is not advisable to carry on for any length of time. Before continuing, check the integrity of the electrode surface and tip and if necessary regrind the tip.
- 12.2.1** To cease welding lift the electrode from the weld pool in order to extinguish the arc.
- 12.3 SWITCH OFF** the welder and turn off the gas at the cylinder valve.

13. ARC WELDING CONNECTIONS

Fig.21



NOTE: Normally all coated electrodes are connected to the positive terminal (+) of the power source, with the exception of acid coated electrodes which are connected to the negative terminal (-).

13.1 ELECTRODE HOLDER

The plug at the end of the electrode cable will normally be connected to the positive socket (+) on the front panel (see fig.22 item 3).

13.2 WORK CLAMP CABLE The plug at the end of the clamp cable will normally be connected to the negative socket (-) on the front panel (see fig.22 item 2).

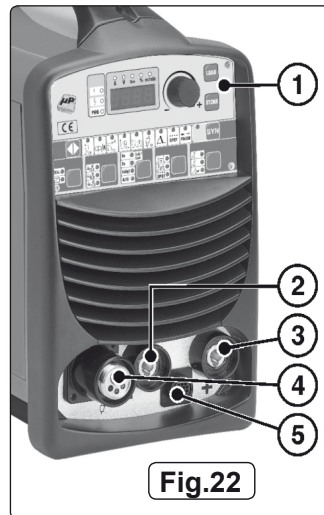

Fig.22

14. ARC WELDING PROCEDURE

- 14.1 The PULSEMIG225 will also perform ordinary arc welding (without gas) using coated electrodes.(You will need optional arc Accessory Kit INV/25)
- 14.2 **Please note that the way the welding cables are connected to the inverter for ordinary arc welding may be different to the way the cables are connected for standard TIG welding. Whilst most stick electrodes are connected to the positive terminal certain types need to be connected to the negative terminal. It is therefore essential that the user refers to the electrode manufacturers instructions to ensure that the correct polarity is selected.**
- 14.3 The mechanical characteristics of the weld will be determined not only by the current used but also by other factors such as the diameter and quality of the electrode itself as well as the arc length, the speed of welding and the orientation of the electrode to the work surface. Unused electrodes should also be protected from moisture as a damp electrode will affect the quality of the weld.
- 14.4 The following table gives a general guide to the minimum and maximum welding currents to be used with the different diameter electrodes.

Electrode diameter (mm)	Welding current		
	Min.	-	Max.
1.6	25	-	50
2	40	-	80
2.5	60	-	110
3.2	80	-	160
4	120	-	200
5	150	-	280

- 14.5 Depending on the diameter of the electrode the current used will have to be varied depending on the orientation of the workpiece itself. Higher current values will be used for flat welding whereas the current will have to be reduced for vertical or overhead welding.
- 14.6 **ARC FORCE.** When using the optional remote control with two potentiometers (See INV/TIG/7 in section 5.5.2) an additional parameter of 'arc force' becomes available. Arc force relates to the dynamic behaviour of the machine. Higher values of arc force result in higher penetration and enable welding in any position using basic electrodes. By contrast, lower values of arc force result in a softer arc without sparks using rutile electrodes.
- WARNING! Use welding head shield to protect eyes and avoid exposing skin to ultraviolet rays given off by electric arc. Wear safety welding gauntlets.**
If difficult welds are to be performed and the welding parameters are unknown, it is advisable to carry out several trial runs on test pieces in order to determine the right welding current.
- 14.7 **SWITCH ON** the welder only when you are satisfied that the welder is correctly connected and the work to be done is fully prepared.
Setting the controls.
- 14.8 Select the arc welding mode on the front panel. See key 8 in section 5.
- 14.9 Set the welding current required by rotating the encoder knob until the display shows the value you require.
- 14.10 **Striking the arc.** Strike the electrode tip on the workpiece as if you were striking a match. (Do not hit the electrode on the work piece as this could damage the electrode and make strike up difficult.)
- 14.11 **Welding.** As soon as the arc is ignited try to maintain a distance from the workpiece equal to the diameter of the electrode in use and maintain this distance throughout the duration of the weld. Remember that the angle of the electrode as it advances should be 20 to 30° from a vertical line over the workpiece. See fig.24 below.
(See also guide to weld bead characteristics in 'Troubleshooting'.)
- 14.12 At the end of the weld bead, move the electrode backwards in order to fill the weld crater and then quickly lift the electrode from the weld pool in order to extinguish the arc.
- 14.13 **SWITCH OFF** the welder after use.

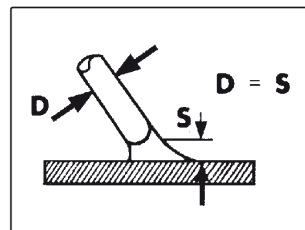

Fig.23

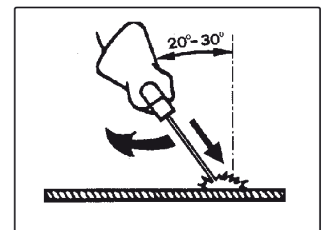

Fig.24

15. MAINTENANCE

▲ DANGER! Unplug the inverter from the mains power supply before connecting or disconnecting cables or performing maintenance or service. Direct contact with the inverter circuit is dangerous.

- 15.1 To avoid a build up of dust inside the machine which may block or restrict the ventilation system, periodically remove the covers and remove the dust with a low pressure air jet or vacuum cleaner. Replace covers immediately. Under no circumstances should the machine be operated with the covers removed.
- 15.2 **TORCH.** Avoid resting the torch and its associated cable on any hot surfaces. If the insulation is damaged in any way the torch cannot be used.
- 15.3 Periodically check the condition of the gas tubing and the connections.
- 15.4 In the event of any problems of unsatisfactory weld performance please first go through the troubleshooting procedure shown below. If this does not solve the problem the Inverter must be taken to a qualified and authorised service agent for repair. Contact your local Sealey dealer for service.
- 15.5 Replacing the torch liner for MIG/MAG welding.**
- 15.5.1 Before proceeding to replace the liner lay out the torch cable straight without any bends.
- 15.5.2 Remove the nozzle and unscrew the contact tip (See fig.11-a&b).
- 15.5.3 Unscrew the hose locking nut on the central connector and extract the old hose.
- 15.5.4 Insert the new hose into the cable torch duct and push it gently until it comes out of the torch head.
- 15.5.5 Tighten up the hose locking nut by hand.
- 15.5.6 Trim off all excess protruding hose.
- 15.5.7 Remove liner from the torch cable and smooth out any distortion caused when the liner was cut.
- 15.5.8 Re-insert liner and tighten locking nut with a spanner.
- 15.5.9 Reassemble the contact tip and nozzle.

16. TROUBLESHOOTING

- 16.1 **Fault indicator is illuminated.** When this LED illuminates the machine will be 'blocked' and one of the following alarm conditions will appear on the display. The machine will automatically be restored when the cause for the alarm has ceased.
- "AL.1" An intervention of the primary circuit safety thermostat has happened due to the machine overheating (MIG pulse version only).
- "AL.2" one of the safety thermostats has triggered due to the machine overheating.
- "AL.3" Failure in the primary power supply: the power supply voltage is 15% above or below the rating plate value. **ATTENTION exceeding the higher voltage limit will seriously damage the machine.**
- "AL.4" Failure in the primary input: protection intervention due to mains undervoltage (MIG pulse version only).
- "AL.7" There has been an attempt at a MIG/MAG weld with a current that is too high for the power source.
- "AL.8" Failure in the MIG/MAG welding circuit (MIG pulse version only) **ATTENTION:** In this case it is necessary to switch the machine off and on again in order to reset it.
- 16.2 **Overheating.** This may occur for one of the following reasons : -
- Inverter casing is full of dust making cooling system inefficient. *Clean as described in section 9.1.*
 - Fan not working. *Have fan renewed by authorised service agent.*
 - Electrode does not match the collet and collet body fitted within the torch. *Obtain and fit the correct size of torch components for the electrode selected.*
 - Bad connection in welding cable and/or work clamp has made poor connection with workpiece. *Check and clean all connections..*
- 16.3 **Poor weld quality.**
- Refer to arc weld bead diagrams to the right and to troubleshooting guide below.
 - Check condition of electrode. It should be ground to the correct shape as seen in fig.7 and should be symmetrically conical.
 - Check that correct gas flow is being used.
 - Check that correct ceramic nozzle is fitted to torch.

- 16.4 **Difficulty in striking an arc.**
This is usually due to the electrode not being in good condition. Grind to correct shape or replace.
- 16.5 **Incompatible settings.** In some instances the machine will not work due to the fact that a combination of settings has been chosen that are electrically incompatible. In such instances no damage can be caused to the machine but it will be necessary to review and alter the settings to a more appropriate combination.
- 16.6 ARC WELDING**
- 16.6.1 **Burning through thin metal:** On very thin sheet, e.g. car body work, the lowest amperage setting may be too fierce. In this case revert to TIG welding.
- 16.6.2 **Machine cuts out:** Refer to fault indicator information above.
- 16.6.3 **Difficulty in striking an arc:**
- The electrode is damp. Heat it up to 60° - 70° before using.
 - Wrong type of rod.

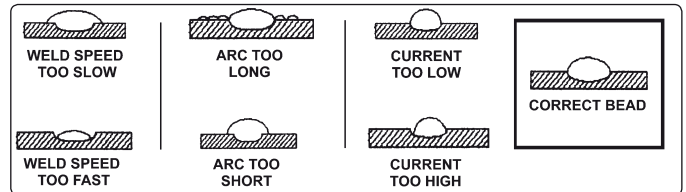

PROBLEM/FAULT	POSSIBLE CAUSES	SOLUTION
UNEVEN WIRE FEED	<ol style="list-style-type: none"> Pressure of wire feed rollers Wire guides are not aligned with grooves on small rollers. Feed rollers or wire tip unsuitable for wire Wire guide hose blocked Coils overlapping on reels Oxidised or poor quality wire Excessive reel braking Coils fallen under the reel 	<ol style="list-style-type: none"> Make sure the rollers allow the wire to slide, and adjust the pressure accordingly. Make sure the wire is not bent and align as necessary. Check and replace if necessary. Remove the hose, blow compressed air through it or replace it. Check and replace the reel if necessary. Cut any oxidised coils or replace the reel. Adjust reel braking lock. Adjust reel braking.
POROUS WELD	<ol style="list-style-type: none"> Gas supply connected incorrectly Gas bottle empty, valve closed Solenoid valve not working with torch button 'on' Faulty pressure reducing valve Torch diffuser holes blocked Drafts in the welding area Gas leaks Wire guide tip too far in Pieces to be welded of poor quality Poor gas or wire quality 	<ol style="list-style-type: none"> Check connections. Open the taps and detach the rubber pipe to check whether gas output is normal. Check for the presence of a voltage at the ends of the reel: if positive replace the solenoid valve. Check. Remove the diffuser and unblock the holes. To prevent clogging spray the diffuser with silicon-free spray. Protect the arc area with suitable shields. Check the gas pipe clips are tightened properly and further tighten if necessary. Check. Ensure workpiece is not wet, dirty, or rusty. Replace wire reel or gas bottle, note that the gas should be dry and not damp.
WIRE DOES NOT FEED	<ol style="list-style-type: none"> Faulty torch button Overload thermostat triggered Control circuit fuses Gear motor failure Fault in electronic circuits for feed rate control 	<ol style="list-style-type: none"> Check and replace. Wait a few minutes for the machine to cool Check and replace. Check and replace. Check and replace the board.
NO WELDING CURRENT	<ol style="list-style-type: none"> Faulty contact Worn contactor contacts Adjustment switch Faulty rectifier Fault in the electronic board Earth cable prepared incorrectly 	<ol style="list-style-type: none"> Make sure that 24V is present at the end of the reel. If not replace the reel. Check the state of the contacts and clean them or replace them if they are very oxidised. Check the secondary voltage for every switch position. Disconnect the secondary rectifier and make sure that each diode conducts in one direction only. Replace the electronic board. Connect the earth cable directly to the piece being welded; make sure the cable is undamaged and locked tightly to the earth clamp.

17. RATINGS PLATE SYMBOLS

Detailed technical data relative to the performance of the machine is located on the back panel plate. Please note that the ratings plate shown below is an example only intended to assist with the explanations of symbols. To determine the correct technical values of the machine in your possession, you must refer to the data plate.

- 1 The EUROPEAN standard regarding safety and the construction of arc welding machines.
- 2 Symbol for the internal structure of the welder
- 3 Symbols for the welding procedure provided
- 4 Symbol **S** : indicates that welding operations may be carried out in environments with heightened risk of electric shock (e.g. very close to large metallic volumes)
- 5 Symbol for power supply line i.e. single phase alternating voltage or three phase alternating voltage
- 6 Protection rating of the covering
- 7 Technical specification for power supply line:
U₁ : Alternating voltage and power supply frequency of the machine (allowed limits $\pm 10\%$)
U_{IMAX} : Maximum current absorbed by the line
U_{IEFF} : Effective current supplied.
- 8 PERFORMANCE OF THE WELDING CIRCUIT:
U₀ : Maximum voltage with no-load peak (welding circuit open)
I₀ / U₀ : Current and corresponding normalised voltage that the welder can supply during welding
X : Intermittent welding ratio: Indicates time during which machine can supply the corresponding current (same column). This is expressed in % on the basis of a 10min. cycle (e.g. 60% = 6 min of work, 4 min. break and so on).

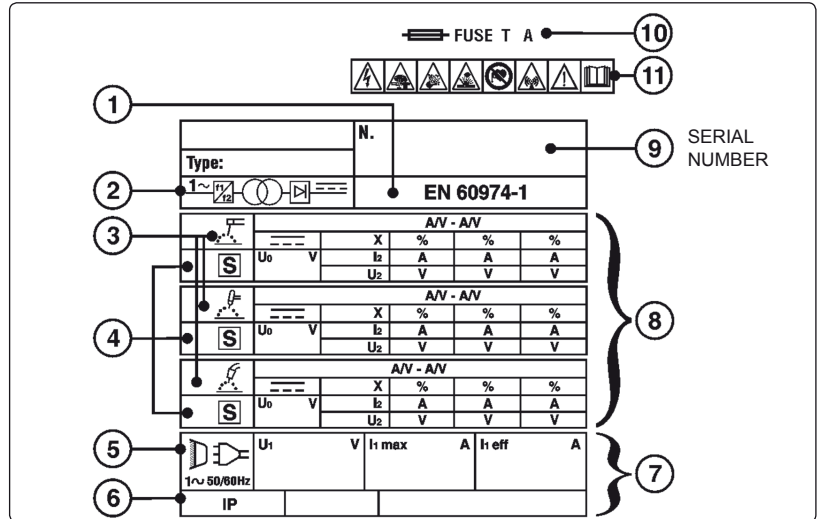

AV-AV : Indicates the regulation range of the welding current (maximum - minimum) at the corresponding arc voltage.

- 9 Manufacturer's Serial No. Indispensable for spare parts and technical assistance
- 10 Value of delayed action fuses for mains protection.
- 11 Symbols referring to safety regulations

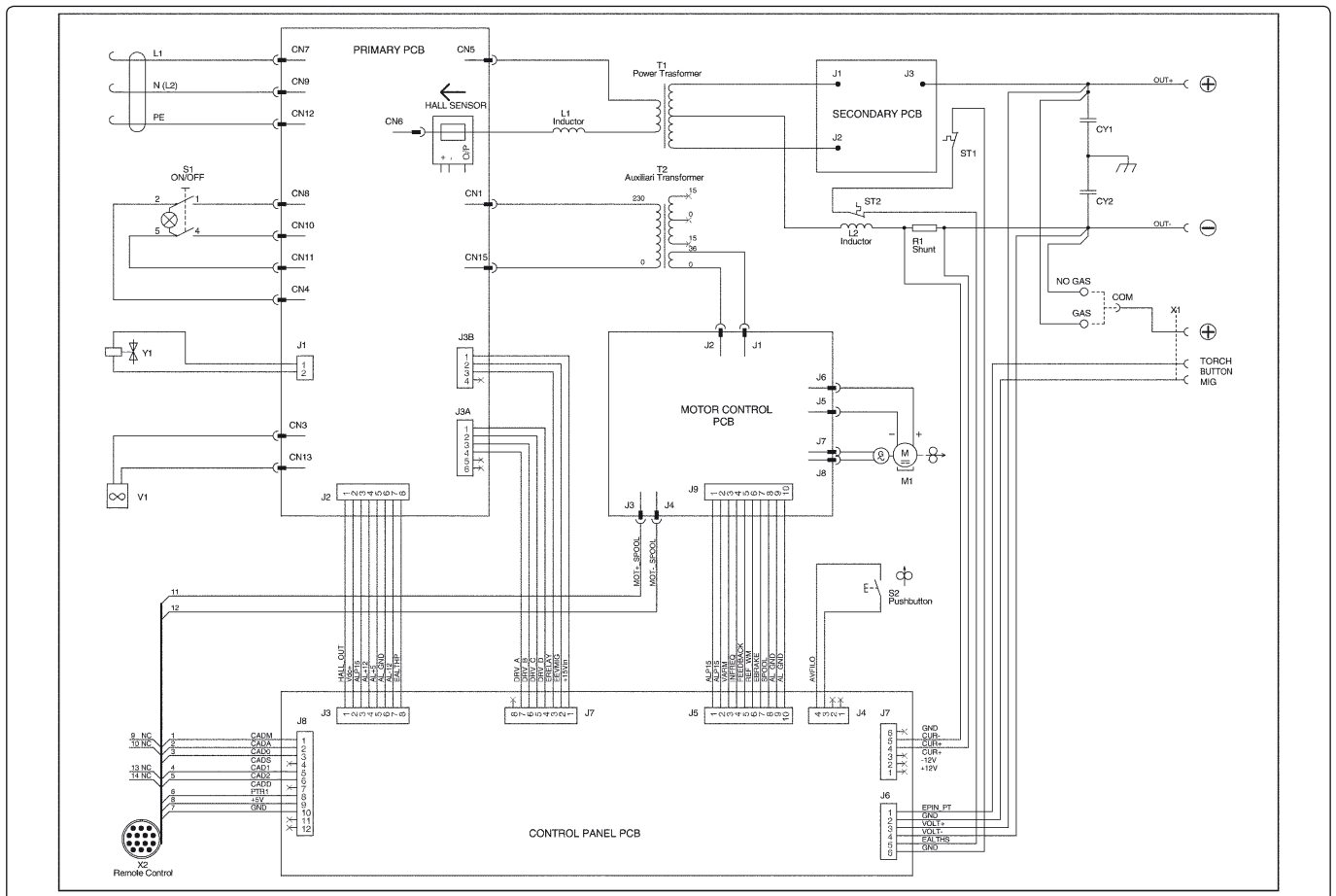

PULSEMIG225 WIRING DIAGRAM



Model No:

PULSEMIG225.V2

Environmental Protection.



Recycle unwanted materials instead of disposing of them as waste. All tools, accessories and packaging should be sorted, taken to a recycle centre and disposed of in a manner which is compatible with the environment.



When the product is no longer required, it must be disposed of in an environmentally protective way.

NOTE: It is our policy to continually improve products and as such we reserve the right to alter data, specifications and component parts without prior notice.

IMPORTANT: No liability is accepted for incorrect use of this product.

WARRANTY: Guarantee is 12 months from purchase date, proof of which will be required for any claim.

INFORMATION: For a copy of our latest catalogue and promotions call us on 01284 757525 and leave your full name and address, including postcode.



Sole UK Distributor, Sealey Group,
Kempson Way, Suffolk Business Park,
Bury St. Edmunds, Suffolk,
IP32 7AR



01284 757500



www.sealey.co.uk



01284 703534



sales@sealey.co.uk