



3 DRAWER HEAVY-DUTY HANG-ON LOCKER

MODEL NO: **PTB39003.V2**

Thank you for purchasing a Sealey product. Manufactured to a high standard, this product will, if used according to these instructions, and properly maintained, give you years of trouble free performance.

IMPORTANT: PLEASE READ THESE INSTRUCTIONS CAREFULLY. NOTE THE SAFE OPERATIONAL REQUIREMENTS, WARNINGS & CAUTIONS. USE THE PRODUCT CORRECTLY AND WITH CARE FOR THE PURPOSE FOR WHICH IT IS INTENDED. FAILURE TO DO SO MAY CAUSE DAMAGE AND/OR PERSONAL INJURY AND WILL INVALIDATE THE WARRANTY. KEEP THESE INSTRUCTIONS SAFE FOR FUTURE USE.



Refer to instruction manual



Wear protective gloves

1. SAFETY

- WARNING!** Ensure Health & Safety, local authority, and general workshop practice regulations are adhered to when using this locker.
- Keep the work area clean, uncluttered and ensure there is adequate lighting.
- Keep the locker clean and tidy in accordance with good workshop practice.
- DO NOT** use the locker for any purpose other than that for which it is designed.
- DO NOT** step on the shelves or drawers.
- DO NOT** overload the locker.
- DO NOT** clean the locker with any solvents which may damage the surfaces or protective coating.

2. INTRODUCTION

Heavy duty welded steel construction for strength and durability. Textured powder coat finish. Ball-bearing drawer slides provide superior performance and carry heavier loads. All drawers have full width sand blasted aluminium 'Lift & Latch' drawer pulls, making easy-access while preventing inadvertent opening when being moved. Non-slip drawer liners supplied for all drawers. Integral locking system, supplied with 2 keys. Hang-On locker suitable for heavy duty Premier rollcabs.

3. SPECIFICATION

Model No..... **PTB39003**
 Overall size (W x D x H)..... 390 x 460 x 1390mm
 No. of Drawers 3
 No. of Shelves..... 2

4. CONTENTS

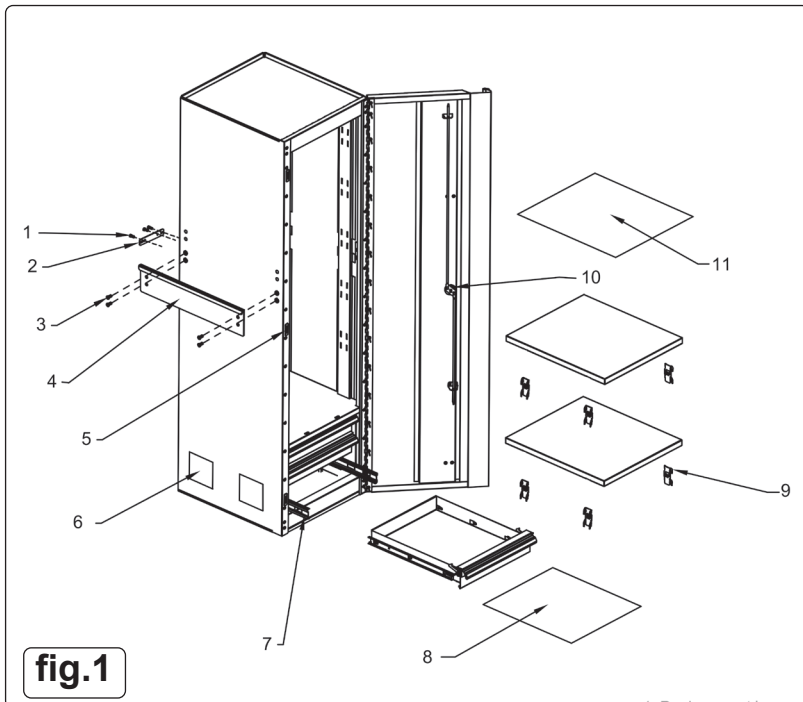

ITEM	DESCRIPTION	QTY
1	M6 x 16 Hex bolt	3
2	Connecting piece	1
3	M6 x 16 c/sink screw	4
4	Hangar	1
5	Magnet	3
6	EVA Pad	2
7	Slide set	3 sets
8	Drawer liner	3
9	Shelf support	8
10	Lock	1
11	Shelf liner	3

5. ASSEMBLY

NOTE: Heavy item - get assistance to assemble.

- 5.1. Securely attach hanger (fig.1 - item 4) using screws (fig.1 - item 3).
- 5.2. Place neoprene pad spacers (fig.1 - item 6) (5 x 40 x 80) near lower edge of locker. (see fig.3). The spacer pads have adhesive backs to enable fixing. See fig.3.
- 5.3. Hang the locker onto the side of the cabinet.
- 5.4. Attach connector (fig.1 - item 2) to the side of the locker using the bolts (fig.1 - item 1). See fig.2.
- 5.5. To support shelves, insert shelf supports (fig.1 - item 9) at the desired height making sure that all pairs are at the same level. See fig.4.

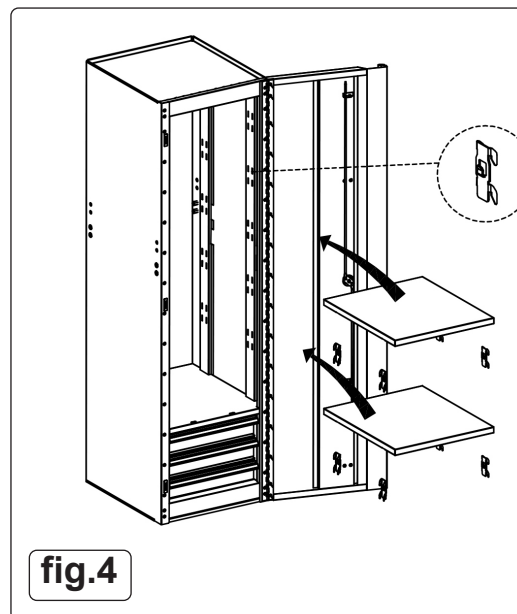
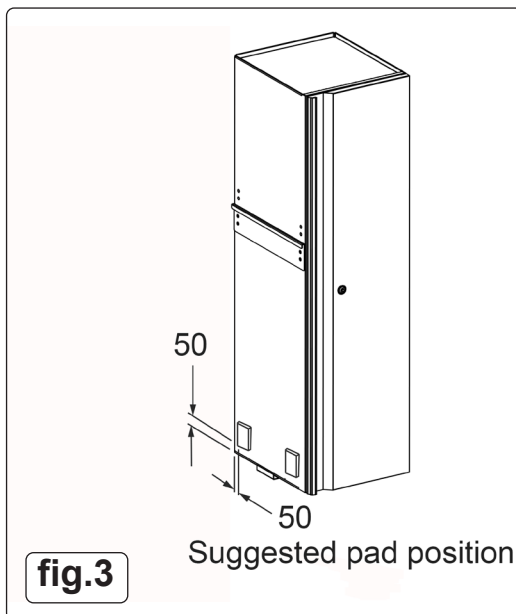
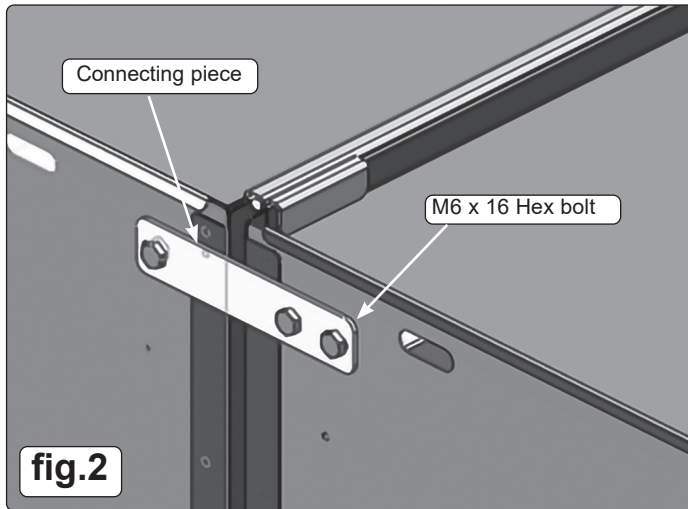

ENVIRONMENT PROTECTION

Recycle unwanted materials instead of disposing of them as waste. All tools, accessories and packaging should be sorted, taken to a recycling centre and disposed of in a manner which is compatible with the environment. When the product becomes completely unserviceable and requires disposal, drain any fluids (if applicable) into approved containers and dispose of the product and fluids according to local regulations.



REGISTER YOUR PURCHASE HERE

Note: It is our policy to continually improve products and as such we reserve the right to alter data, specifications and component parts without prior notice.

Important: No Liability is accepted for incorrect use of this product.

Warranty: Guarantee is 12 months from purchase date, proof of which is required for any claim.

Sealey Group, Kempson Way, Suffolk Business Park, Bury St Edmunds, Suffolk. IP32 7AR



01284 757500



sales@sealey.co.uk



www.sealey.co.uk