



0.5 TONNE PLAIN TROLLEY

MODEL NO: **PT500.V3**

Thank you for purchasing a Sealey product. Manufactured to a high standard, this product will, if used according to these instructions, and properly maintained, give you years of trouble free performance.

IMPORTANT: PLEASE READ THESE INSTRUCTIONS CAREFULLY. NOTE THE SAFE OPERATIONAL REQUIREMENTS, WARNINGS & CAUTIONS. USE THE PRODUCT CORRECTLY AND WITH CARE FOR THE PURPOSE FOR WHICH IT IS INTENDED. FAILURE TO DO SO MAY CAUSE DAMAGE AND/OR PERSONAL INJURY AND WILL INVALIDATE THE WARRANTY. KEEP THESE INSTRUCTIONS SAFE FOR FUTURE USE.



Refer to instructions

1. SAFETY

- ✓ Keep trolley and beams in good working order and condition. Follow the inspection requirements as described in 'Maintenance'.
- ✓ Take immediate action to repair or replace damaged parts by contacting your supplier.
- ✓ Ensure that all accessory lifting devices are suitably certified. If damaged, remove from service immediately.
- ✓ The trolley is designed to travel on a beam and carry a load up to the rated capacity.
- ❑ **WARNING!** The capacity indicated on the trolley (see nameplate) is the maximum safe working load which must not be exceeded.
- ✓ Keep children and unauthorised persons away from the working area.
- ✓ Keep working area clean and tidy, free from unrelated materials and ensure that there is adequate lighting.
- ✓ Ensure that load does not exceed the maximum capacity of the trolley. Overloading the trolley is dangerous.
- ✓ Where appropriate, use only the lifting points recommended by the manufacturer of the item to be lifted, e.g. vehicle engine.
- ✓ Ensure that load does not exceed the maximum capacity of the I Beam that the trolley is attached to.
- ✓ Before lifting the load ensure that there are no obstacles which may snag the load whilst it is being lifted.
- ✓ To avoid injury, be fully aware of your own and other persons locations in relation to the lifting, and lowering, of the load.
- ✓ Keep a sound footing and balance, and ensure the floor is not slippery.
- ✗ **DO NOT** harness the load at an angle or use any attachments not verified as fit for purpose.
- ✗ **DO NOT** allow the load to swing during lifting.
- ✓ Lower load with care, ensuring that you are fully aware of the condition of the surface onto which the load is to be placed.
- ✗ **DO NOT** position any part of your body beneath the load.
- ✗ **DO NOT** use this product to perform a task for which it is not designed.
- ✗ **DO NOT** use whilst under the influence of drugs, alcohol or intoxicating medication.
- ✗ **DO NOT** lift or transport loads while personnel are in the danger zone.
- ✗ **DO NOT** allow personnel to pass under a suspended load.
- ✗ **DO NOT** use the trolley for transportation of people.
- ✗ **DO NOT** use the trolley in explosive or corrosive environments.
- ✗ After lifting, **DO NOT** leave the load suspended for longer than necessary.
- ✓ Start moving the load only after it has been attached correctly and all personnel are clear of the danger zone.
- ✓ When not in use, store in a safe, dry, childproof area.
- ✓ This trolley is designed for use within a garage or workshop environment, ambient operating temperature between - 10°C and + 50°C.
- ❑ **WARNING!** Failure to heed safety and warning instructions may result in damage and/or personal injury, and will invalidate the warranty.

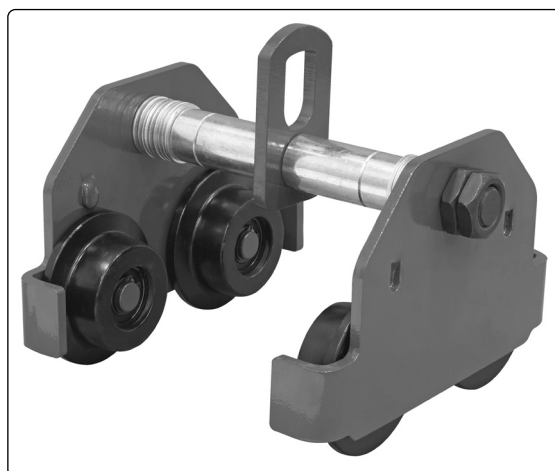

2. INTRODUCTION

Heavy-duty steel construction with powder coat paint finish for corrosion resistance. Fits a wide range of RSJ and I-beams. Adjustable between 68-126mm. Suitable for use with our lever hoists or chain blocks range. Designed for mounting onto an I-beam or RSJ to allow load to be manoeuvred sideways. Incorporates wheel guards to prevent contact with other trollies mounted on same load bearer.

3. SPECIFICATION

Model No:	PT500.V3
Capacity:	500kg
Nett Weight:	4.8kg
Test Load:	750kg
Track Width Adjustable Range:	68-126mm

4. ASSEMBLY

NOTE: the numbers in brackets refer to item numbers as shown in the diagram.

- 4.1. Measure the actual width of the runway beam.
- 4.2. Evenly assemble the required number of spacer washers to the inside of the trolley side plates so that the dimension between trolley wheel flanges (2) are 6mm (MAX) greater than the runway beam width.
- 4.3. Assemble the remaining washers outside the trolley side plates (1). Fit washers (7) and nuts (8) to the hanger pin (10).
NOTE: there must always be at least one washer on the inside and the outside of each trolley side plate.
- 4.4. Slacken the hanger pin nuts (8) and spread the side plates (1) so the wheels (2) can be slipped over the runway beam.
- 4.5. Screw the nuts (8) firmly against the washers (7).
- 4.6. Suspend a light load from the trolley to ensure that all four wheels (2) contact the runway beam.
- 4.7. Tighten the nuts and then secure with the second (lock) nut.

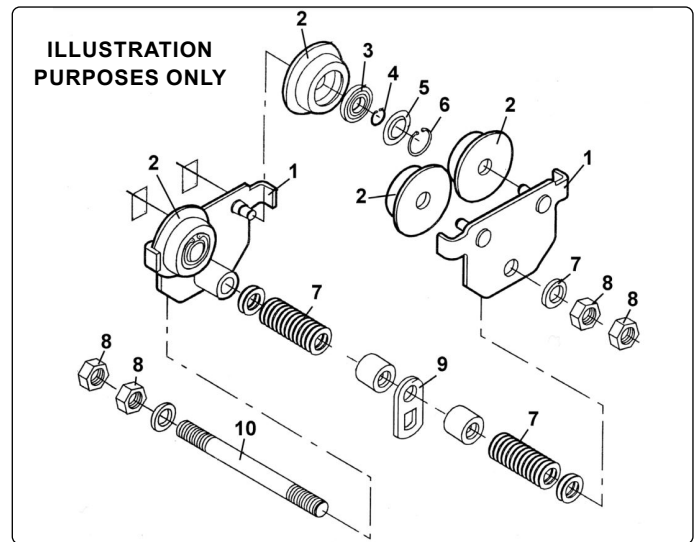

5. OPERATION

IMPORTANT: Before operating the trolley, ensure you have read and understood the safety instructions. Refer to **6.2 - Inspection** before each and every use. Perform a risk assessment before undertaking any operations with the trolley.

- 5.1. Connect the trolley to the load using a suitable certified chain hoist or similar. Ensure you are aware of the load weight, and check that it is within the capacity of the trolley and the support beam. Ensure you know the weight to be lifted.
- 5.2. Use only lifting points sufficient to hold the weight.
- 5.3. Lift only from directly above the load.
 WARNING! DO NOT lift the load at an angle.
- 5.4. The load is moved by pushing the attached hoist or load.
 WARNING! You must seek assistance if the load size prevents adequate visibility of the zone in front of the load.
- 5.5. When the load has been secured, remove the lifting sling, support beam etc. and place the trolley in a safe location.

6. MAINTENANCE

IMPORTANT: the trolley must be kept clean and dry and must be maintained in accordance with these instructions.

6.1. LUBRICATION

- 6.1.1. Oil all working parts monthly, or more frequently in dusty conditions.

6.2. INSPECTION BEFORE USE

- 6.2.1. Before each use of the trolley you must perform an inspection for damaged, loose, missing parts, corrosion, wear, or other irregularities.
- 6.2.2. The trolley must be examined immediately if it has been subject to an abnormal load or shock. It is recommended that such an examination is made by an authorised service agent.
- 6.2.3. The owner and/or operator must be aware that repair of this equipment will require specialised knowledge and facilities. It is recommended that an annual examination of the trolley is made by an authorised service agent.
- 6.2.4. Unauthorised parts may be dangerous and will invalidate the warranty.

6.3. DEFINITION OF 'INSPECTION' & 'EXAMINATION'

- 6.3.1. **Inspection.** Looking at the trolley for defects and checking the operation without loading the trolley. This is much more than a check but does not normally require any part of the trolley to be dismantled. Inspections are instigated by the user.
- 6.3.2. **Examination.** Verification that the trolley can safely continue in service including a functional test to verify that it operates within the required tolerances. An examination is more thorough than an inspection. All examinations and inspections should be carried out by a competent person.

7. RESPONSIBILITIES

The owner and/or operator shall study these instructions and retain them for future use.

7.1. UNDERSTANDING INSTRUCTIONS & WARNINGS

The owner and/or operator shall understand the operating instructions and warnings before operating the trolley. Warning information must be emphasised and understood.

If the operator is not fluent in English, the product instructions and warnings must be read to, and discussed with, the operator in the operator's native language by the owner, making sure the operator understands the contents.

7.2. DAMAGED TROLLEYS

Any trolley which appears to be damaged, badly worn, or operates abnormally **MUST BE REMOVED FROM SERVICE.**

It is recommended that necessary repairs be made by an authorised service agent.

7.3. END OF SERVICE

Through years of normal wear, the trolley will eventually become unserviceable. When this happens dispose of in accordance with local authority regulations.



ENVIRONMENT PROTECTION

Recycle unwanted materials instead of disposing of them as waste. All tools, accessories and packaging should be sorted, taken to a recycling centre and disposed of in a manner which is compatible with the environment. When the product becomes completely unserviceable and requires disposal, drain any fluids (if applicable) into approved containers and dispose of the product and fluids according to local regulations.



REGISTER YOUR PURCHASE HERE

Note: It is our policy to continually improve products and as such we reserve the right to alter data, specifications and component parts without prior notice. Please note that other versions of this product are available. If you require documentation for alternative versions, please email or call our technical team on technical@sealey.co.uk or 01284 757505.

Important: No Liability is accepted for incorrect use of this product.

Warranty: Guarantee is 12 months from purchase date, proof of which is required for any claim.

Sealey Group, Kempson Way, Suffolk Business Park, Bury St Edmunds, Suffolk. IP32 7AR



01284 757500



sales@sealey.co.uk



www.sealey.co.uk