



INSTRUCTIONS FOR: PALLET TRUCK MODEL No: PT2500

Thank you for purchasing a Sealey product. Manufactured to a high standard this product will, if used according to these instructions and properly maintained, give you years of trouble free performance.

IMPORTANT: PLEASE READ THESE INSTRUCTIONS CAREFULLY. NOTE THE SAFE OPERATIONAL REQUIREMENTS, WARNINGS & CAUTIONS. USE THE PRODUCT CORRECTLY AND WITH CARE FOR THE PURPOSE FOR WHICH IT IS INTENDED. FAILURE TO DO SO MAY CAUSE DAMAGE AND/OR PERSONAL INJURY AND WILL INVALIDATE THE WARRANTY. PLEASE KEEP INSTRUCTIONS SAFE FOR FUTURE USE.

1. SAFETY INSTRUCTIONS

- X **DO NOT** use a faulty or damaged pallet truck.
- ✓ Before using the pallet truck, all parts and working mechanisms should be checked for wear or damage. Pay particular attention to the wheels, handle, fork lifting and lowering mechanism. Any parts found to be worn, damaged or suspect should be repaired or replaced before the truck is used.
- ✓ All repairs must be carried out by an authorised Sealey service agent.
- ✓ Personnel who operate the pallet truck and those in the vicinity of operation should wear safety shoes with reinforced toe caps at all times.
- X Never place any part of your body in the lifting mechanism or under the forks or load.
- X **DO NOT** allow others to ride on the pallet truck.
- X **DO NOT** lift or move unstable or loosely stacked loads.
- ✓ Take special care when moving long, high or wide loads in order not to dislodge the load by striking any architectural features, permanent fixtures, vehicles or people in the area of operation.
- ✓ Always ensure that the load is evenly distributed across the forks with the centre of the load being at the halfway point of the length of the forks.
- X **DO NOT** overload the pallet truck - refer to the specification for maximum permitted load.
- ✓ If a load is left unattended or if not in use even for a very short period of time it should be lowered to the ground.
- ✓ Ensure that the width and length of the forks is correct for the pallet to be lifted.
- ✓ Ensure that the pallet truck is sufficiently inserted into the pallet to lift the full depth of the pallet.
- ✓ Use the pallet truck on level, flat, hard surfaces.
- ✓ The operator of the pallet truck must be physically capable of controlling the load selected; particularly in relation to stopping a rolling load.
- ✓ When the pallet truck is not in use, lower the forks and park it where it will not be a hazard.
- ✓ The pallet truck is designed for indoor use +5°C and +40°C.
- X **DO NOT** use on sloping or uneven ground and do not attempt to negotiate curbs, steps or ramps.

2. INTRODUCTION & SPECIFICATION

Introduction. Heavy-duty trucks suitable for warehouse and general handling duties. Polyurethane, non-marking wheels and tandem loading rollers with sealed-for-life bearings all round. Robust and durable galvanised hydraulic unit with chromed ram and piston for resistance to corrosion. Single bogey-wheels with drop nose for smooth pallet entry.

Specification.

Model No.:	PT2500
Capacity:	2500kg
Minimum height:	85mm
Maximum height:	200mm
Fork Length x Width Overall:	540 x 1150mm
Fork Spread:	230mm

3. ASSEMBLY

- 3.1 Identify the handle pivot pin (5) and tap a roll pin (9) through one end of it so that it sticks out equally either side.
- 3.2 Position yourself behind the truck and insert the handle assembly into the pump casting (see fig.1). Align the pivot holes at the base of the handle with the pivot holes in the casting. Take the pivot pin and orientate it so that the inserted roll pin will lie in the groove made for it in the pump casting.
- 3.3 Using a hammer, insert the pivot pin (5) through both components **from right to left**. Once the pivot pin is in

- position, drive another roll pin through the hole in the other end of the pivot pin.
- 3.4 Move the lever control at the top of the handle into it's highest position and hold it there.
- 3.5 Referring to the inset cross section in fig.1, Insert the chain (2) with adjusting bolt (6) and nut (8) attached through the hole in the centre of the pivot pin.
- 3.6 There is a transit pin just below the main handle pivot which needs to be removed. Lower the handle down so that the rolling sleeve (3) bears down on top of the piston and remove the transit pin.
- 3.7 Move the lever control at the top of the handle into it's lowest position. Then raise the rocking lever plate (7) which sits within the main casting and move the chain adjusting bolt (6) into the slot in the end of the plate so that the adjusting nut (8) is now underneath the plate as shown on the inset cross section in fig.1.
- 3.8 **Apply supplied Company Logo, Instructions, Warnings and Specification stickers/labels to both sides of pallet truck apron. See fig.2 for suggested positions.**

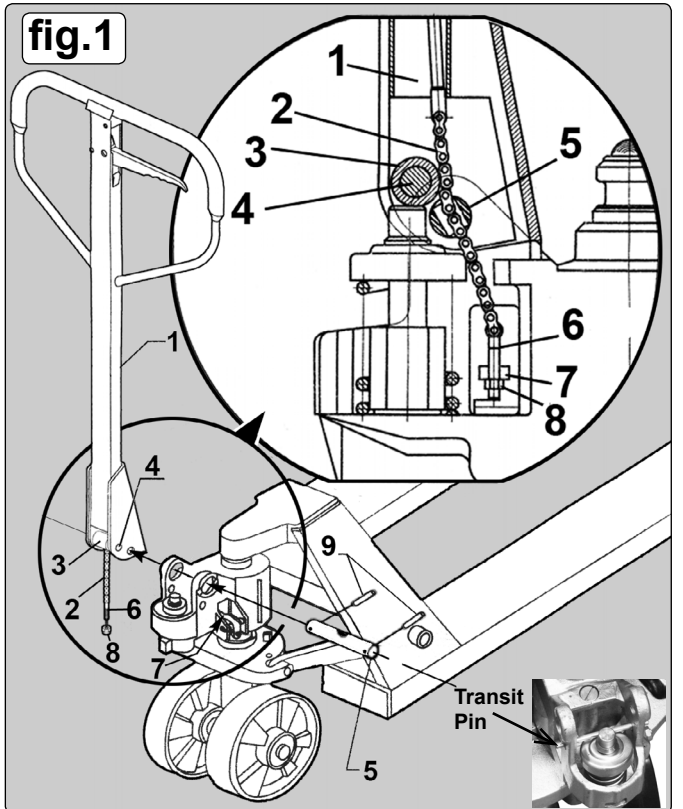

4. ADJUSTMENTS

- 4.1 The control lever (see fig.2) has three positions as follows:-
RAISE - Lever in lowest position.
DRIVE - Lever in centre position.
LOWER - Lever held in up position. When released the lever returns to the drive position.
- 4.2 If the lever does not work in the prescribed way it can be adjusted using the nut (8) at the bottom of the adjusting bolt (6) which is attached to the chain (2). See fig.1.
- 4.3 If the truck elevates whilst pumping in the **Drive** position, turn the adjusting nut clockwise until the pumping action no longer raises the truck and the **Drive** functions correctly.

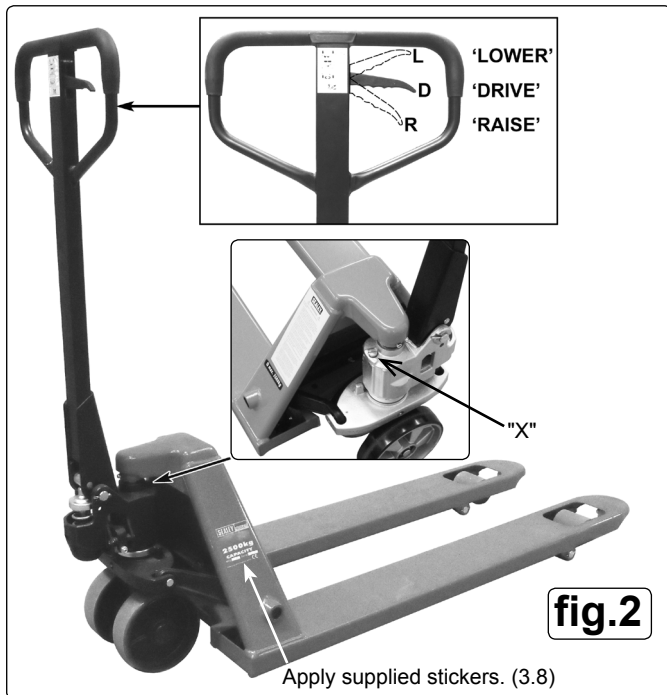

- 4.4 If the truck descends whilst pumping in the **Drive** position, turn the adjusting nut counter clockwise until the truck does not lower.
- 4.5 If the truck does not descend when the control lever is held in the highest position turn the nut clockwise until lowering is achieved. Now check the Drive position as described in sections 4.2 and 4.3.
- 4.6 If the truck does not raise while pumping with the control lever in the lowest position turn the adjusting nut counter clockwise until raising is achieved, then check that the other two control lever positions still function correctly.

5. OPERATING THE TRUCK

- 5.1 Before using the truck you must read and understand the safety instructions in Section 1. The truck should only be operated by those persons who have been trained in its use.
- 5.2 The operator must be physically capable of pushing or pulling the load and must also be capable of stopping a rolling load.
- 5.3 Before lifting any load the operator should check that the pallet is the correct width and length for the truck and that the pallet itself is not damaged.
- 5.4 The operator should ensure that the load on the pallet is safe to move. If the load appears to be loosely stacked, unevenly distributed, too high or too wide it should be repacked safely before moving. Also check that the weight of the load is within the capacity of the truck

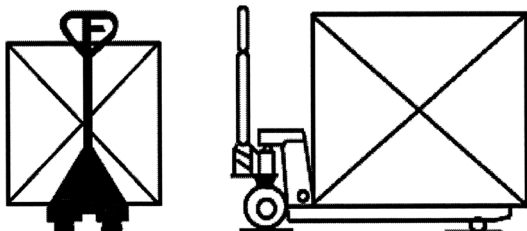

- 5.5 **Lowering the truck.** (See fig.2 - L) Before inserting the truck into the pallet ensure that the truck forks are in their lowest position by pulling the operating lever into the upper position and holding it there until the truck has settled down to the lowest level.

- 5.6 **Drive position.** (See fig.2 - D) The lever can now be released and will return to the middle drive position.
- 5.7 Push the truck into the pallet ensuring that it is fully inserted. If the pallet is shorter than the forks the load should be placed at the centre point of the length of the forks.
- 5.8 **Raising a load.** (See fig.2 -R) To lift the load push the operating lever to its lowest position where it will latch. Pump the handle up and down to lift the load from the floor. When the forks reach their maximum height the lifting action will stop even if you continue to pump the handle.
- 5.9 Before you move off, return the operating lever to its neutral position.
- 5.10 Due care should be taken when manoeuvring a load to ensure that no collision takes place with any objects or people.
- 5.11 The faster the truck is moved the more difficult it will be to stop, proceed at a slow and even pace.
- 5.12 Bring the truck to a stop where required and lower the load to the floor by pulling the operating lever to its highest position and holding it there until the load has settled to the floor.
- 5.13 It is not recommended that the load is lowered whilst the truck is still moving as a sudden stop may dislodge the load causing possible damage to property and/or people.

6. MAINTENANCE

- 6.1 The oil level should be checked every six months. The system contains 0.3ltr. of hydraulic oil which should conform to ISO VG32. The viscosity should be 32cSt at 40°C . (See oil level / filler screw 'X' in fig.2) Sealey hydraulic oil is ideal.
- 6.2 To purge air from the system hold the operating lever in the lowering position until the truck has descended to its lowest level then pump the handle up and down 8 to 10 times.
- 6.3 Apply a long life grease to all bearings and shafts once a month.

7. TROUBLE SHOOTING

THE PROBLEM	THE CAUSE	THE SOLUTION
1. The forks do not reach maximum height.	Hydraulic oil level too low. Too cold.	Top up the oil. Operate at rated temperature.
2. The forks do not raise.	No hydraulic oil	Fill with hydraulic oil
	The oil is contaminated.	Change the oil.
	The lifting/lowering mechanism needs adjustment.	Follow procedure in Section 4.
	Air in the hydraulic system.	Purge the air as described in Section 6.
3. The forks will not descend.	The lifting/lowering mechanism needs adjustment.	Adjust as described in Section 4.
	Truck stored in raised position allowing exposed piston rod to corrode and jam.	Lubricate rod regularly and store truck in lowered position.
	Piston rod or pump body deformed as a result of overloading or unbalanced load.	Replace piston rod or pump body.
4. Leaks.	Seals worn, damaged or cracked.	Replace seals.
5. The forks descend and cannot be maintained in the raised position.	The lifting/lowering mechanism needs adjustment.	Adjust as described in Section 4
	Release valve not fully closed due to impurities in oil.	Change the oil.
	Air in the hydraulic system.	Purge the air as described in Section 6.
	Seals worn, damaged or cracked.	Replace seals.
	Parts of hydraulic system cracked or worn.	Inspect and replace.

Parts support is available for this product. To obtain a parts listing and/or diagram, please log on to www.sealey.co.uk, email sales@sealey.co.uk or phone 01284 757500.

NOTE: It is our policy to continually improve products and as such we reserve the right to alter data, specifications and component parts without prior notice.
IMPORTANT: No liability is accepted for incorrect use of this product.
WARRANTY: Guarantee is 12 months from purchase date, proof of which will be required for any claim.
INFORMATION: For a copy of our latest catalogue and promotions call us on 01284 757525 and leave your full name and address, including postcode.



Sole UK Distributor, Sealey Group,
 Kempson Way, Suffolk Business Park,
 Bury St. Edmunds, Suffolk,
 IP32 7AR

01284 757500

www.sealey.co.uk

01284 703534

sales@sealey.co.uk