

HYDRAULIC RAM UNIT

MODEL NO: **PS990**

1. INTRODUCTION

1.1. INTRODUCTION

The PS990 Hydraulic Ram Piston will fit all Sealey hydraulic puller sets and is also suitable for use with other popular makes of hydraulic gear pullers. Screw mechanism converts power to 10 Ton ram head with enough force to remove most stubborn bearings, pulleys and shafts.

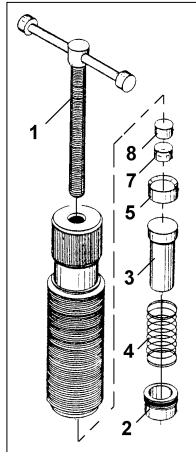

2. CONTENTS & PARTS

Part No.	Description
PS982/8002	Repair Kit (Items 1,2,3,4,5,7,8)
PS982/OIL	15grms of oil for a single refill.
PS982/G	Grease for maintenance of old grease filled rams

Issue No.: -3

Issue Date: -030505

3. SAFETY INSTRUCTIONS

- ❑ **WARNING!** Ensure all Health and Safety, local authority, and general workshop practice regulations are strictly adhered to when using tools.
- x **DO NOT** use ram or associated tools if damaged or worn.
- ✓ Maintain the ram and associated tools in good and clean condition for best and safest performance.
- ✓ Check the specification of the puller tool you will be using to ensure that it is rated to match the force that the ram can apply.
- ✓ Ensure all threads are clean and well lubricated.
- ✓ Always check that the ram is correctly assembled into the puller being used and is square with the workpiece.
- ✓ If working on a raised vehicle, ensure that it is adequately supported with axle stands, ramps, etc. as appropriate.
- ✓ Wear suitable clothing to avoid snagging. Do not wear jewellery. Tie back long hair.
- ✓ Wear approved eye protection. A full range of personal safety equipment is available from your Sealey dealer.
- ✓ Where possible shield workpiece with canvas or similar to provide protection against failed parts.
- x **DO NOT** use any tool or lever to turn the ram tommy bar, use hand effort only.
- x **DO NOT** hit workpiece, or ram, with a hammer if workpiece has not moved with maximum puller force applied. Use a larger capacity puller.
- ✓ Account for all tools and parts being used and do not leave them in or on the vehicle.

4. INSTRUCTIONS FOR USE

- ❑ **WARNING!** Ensure that you read, understand and apply the safety instructions in Section 3. **IMPORTANT:** Always refer to the vehicle manufacturer's service instructions, or proprietary manual, to establish the correct procedure and data. These instructions for use are provided as a guide only.

- 4.2 Check that the specification of the puller tool you will be using is compatible with the ram unit.
- 4.1. Confirm that the workpiece is retained by interference fit (parallel or taper) only.
- 4.2. Assemble the ram into the chosen puller, (see typical pullers as shown in fig.1), and adjust T-handle (Fig. 2.A) so that tommy bar (fig.2.B) is approximately 80mm (3") above top of ram, see fig.2.
- 4.3. Fit the puller to an appropriate position behind workpiece and then screw the ram **body** down until it makes contact with the end of the shaft from which the workpiece is to be pulled. (If the shaft has a centre position machined into its end surface use a matching centre adaptor to locate centrally with the shaft.
- 4.4. Turn T-handle clockwise, by hand only, to pull workpiece from shaft.
- 4.5. Do not screw T-handle in further than 25mm (1") from end of the ram (see fig.2). If workpiece requires additional movement then unscrew T-handle to 80mm from end of ram, screw ram body down so that centre adaptor again contacts shaft and then continue to draw workpiece up shaft.

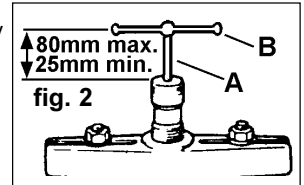

IMPORTANT: The maximum safe load for the puller can be achieved by hand effort alone. **The use of tools or levers on the tommy bar to increase the load will damage the puller and may result in injury.** Such misuse will also invalidate the warranty. If the workpiece does not move, with maximum puller force applied, **DO NOT** hit it, or the puller, in an attempt to jar it free. Damage to puller/workpiece and personal injury may result. Use a larger capacity puller.



5. MAINTENANCE

5.1. GENERAL

- 5.1.1. Keep all items clean and lightly oiled. Keep all threads free from grit and lubricate the ram regularly.
- 5.1.2. Store the ram in the closed position to prevent piston surface corrosion.

5.2. TO CHANGE OIL IN RAM

IMPORTANT: The hydraulic system operates on a specially formulated oil which must be replaced from time to time.

Use Sealey Hydraulic Jack Oil, available from your authorised Sealey dealer. Quote model number:

HJO500MLS for 1 x 500ml bottle or PS982/OIL for 15grms of oil for a single refill.

WARNING! Use of any other oil in ram may cause ram to fail and will invalidate your warranty. Wear appropriate eye, face and hand protection.

- 5.2.1. Dismantle by removing the ram cover (fig.3.2) with soft jaw grips (fig.3.A) (body may have to be held in a soft jaw vice, ensure body thread is not damaged). *Caution! The cover is spring loaded, take care when removing.* Carefully remove components 2, 3, and 4 from the cylinder.
- 5.2.2. Screw T-handle (fig.4.5) down as far as it will go, then unscrew and remove it from the body (fig.4.5).
- 5.2.3. Push a narrow screw driver (fig.4.9), or a rod of appropriate diameter, down the small opening in head of ram (B), in order to push components 6, 7, and 8, plus the oil, out of the main cylinder. Note: A medium force may be required.
- 5.2.4. Remove remaining oil from main cylinder, clean all components

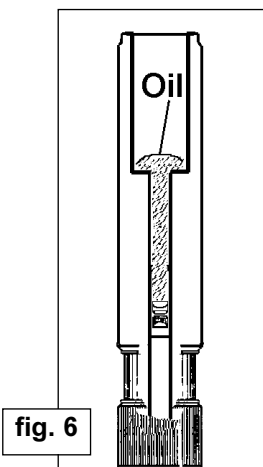
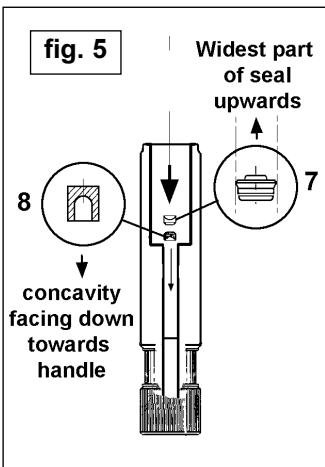
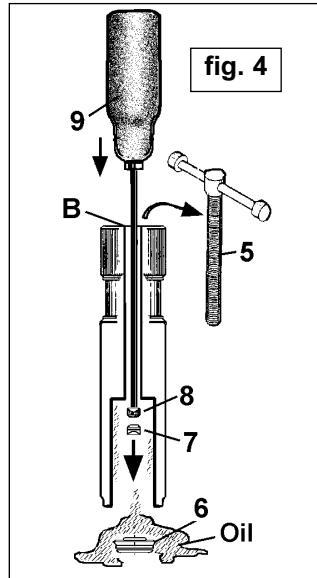
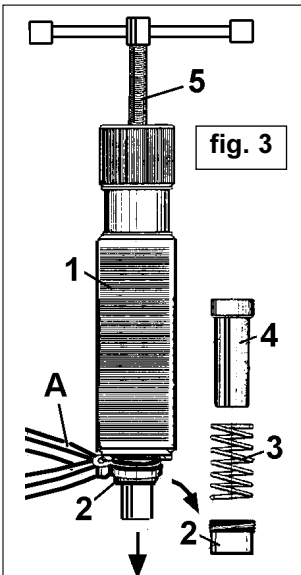

- 5.2.5. Take small seal and piston (fig.5.7 & 8) and gently push them down the narrow bore of the cylinder ensuring the metal piston (8) is first, with the concave face pointing in the direction of the T-handle, and the seal (fig.5.7) second, with the widest part of the seal facing upwards towards the main cylinder (fig.5). Push into bore as far as possible.
- 5.2.6. Pour 15grms of oil into the bore (fig.6). Insert larger seal (fig.7.6) as shown, with the widest part of the seal facing downwards into the bore. Push down into main cylinder as far as 'X' (fig.7) followed by piston (fig.7.4) and spring (fig.7.3).
- 5.2.7. Refit (do not overtighten) ram cover (fig.7.2) and replace T-handle (fig.7.5).
- WARNING!** The correct orientation of pistons and seals in the ram is critical.
- 5.2.8. Screw T-handle into ram until it contacts small piston and then turn a further two or three times.
- 5.2.9. Remove T-handle and firmly bounce the ram piston (fig.8) on a hard, but non-damaging, surface 6 to 10 times to consolidate the oil. Replace the T-handle, wipe clean and the ram is ready for use.

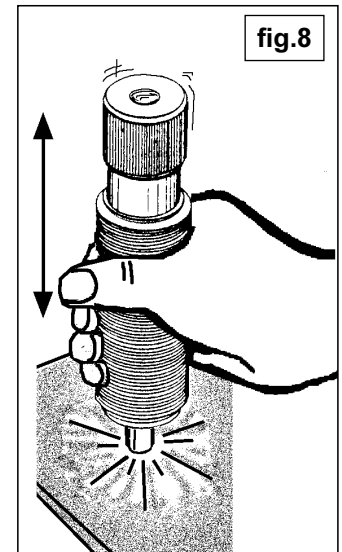
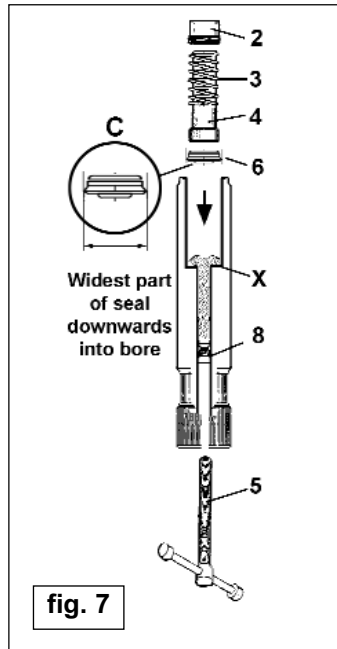

6. SERVICE PARTS & NOTES

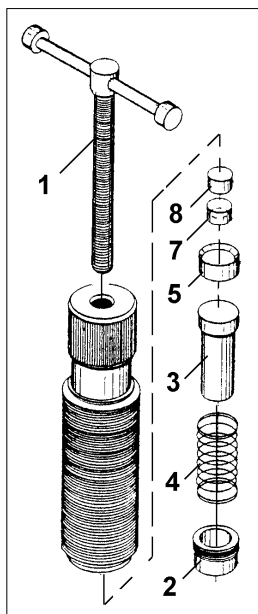

6.0. MAINTENANCE OF EARLY MODELS.

Please note that earlier models of the PS990 were filled with a hydraulic grease. For these models a small amount of grease may be obtained by quoting Part No. PS982/G.

- WARNING!** Do not put oil into units previously filled with grease as the seals will be configured for grease only and will leak if used with oil.

6.1. CONVERTING OLD UNITS TO OIL

The old type grease filled PS990 can be converted for use with oil by replacing the internal components with those supplied in the repair kit shown on left Part No PS982/8002. Do not mix old and new components. A single 15grm refill of oil may be obtained by quoting Part No. PS982/OIL

NOTE: It is our policy to continually improve products and as such we reserve the right to alter data, specifications and component parts without prior notice.

IMPORTANT: No liability is accepted for incorrect use of this product.

WARRANTY: Guarantee is 12 months from purchase date, proof of which will be required for any claim.

INFORMATION: For a copy of our catalogue and latest promotions call us on 01284 757525 and leave your full name, address and postcode.



Sole UK Distributor
Sealey Group,
Bury St. Edmunds, Suffolk.

01284 757500
01284 703534

www.sealey.co.uk
sales@sealey.co.uk