

HYDRAULIC PULLER SET

MODEL NO: **PS981**

1. INTRODUCTION

1.1. INTRODUCTION

The PS981 consists of 3 three-position puller legs with link plates and a forged steel 2 and 3 leg yoke operated by a 10 ton hydraulic ram. The ram is also compatible with sets PS982 and PS983. The combination of three-position legs and link plates gives maximum reach and workpiece diameter of 250mm, enabling the set to be used for a large range of gears, bearings and pulleys.

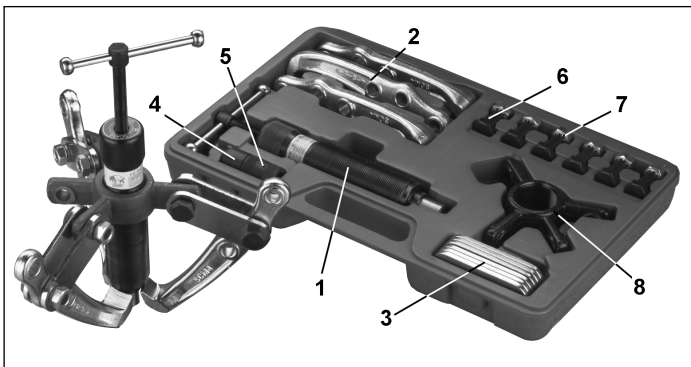

2. CONTENTS & PARTS

Item	Part No.	Description	PARTS LIST	
1	PS990	Ram 10ton	Issue Date:-	12/05/05
2	PS981/02	Leg, Combination, 3 off	Issue No.:-	3
3	PS981/03	Plate, Steel, 6 off		
4	PS981/04	Centre Adaptor		
5	PS981/05	Extension (for centre adaptor)		
6	PS981/06	Screw and Nut Set		
7	PS981/07	Washer, 6 off		
8	PS981/08	Support, Ram		
	PS982/OIL	15grms of oil for single refill.(not shown, not supplied)		
	PS982/8002	Repair Kit for PS990 Ram.(not shown, not supplied)		

3. SAFETY INSTRUCTIONS

- ❑ **WARNING!** Ensure all Health and Safety, local authority, and general workshop practice regulations are strictly adhered to when using tools.
- x **DO NOT** use tools if damaged or worn.
- ✓ Maintain the tools in good and clean condition for best and safest performance.
- ✓ Ensure all threads are clean and well lubricated.
- ✓ Always check that puller is correctly assembled and is square with the workpiece.
- ✓ If vehicle is raised, ensure it is adequately supported with axle stands, ramps, etc. as appropriate.
- ✓ Wear suitable clothing to avoid snagging. Do not wear jewellery. Tie back long hair.
- ✓ Wear approved eye protection. A full range of personal safety equipment is available from your Sealey dealer.
- ✓ Where possible shield workpiece with canvas or similar to provide protection against failed parts.
- x **DO NOT** heat puller jaws when heating a gear or bearing as this will affect the temper and, therefore, the strength of the material.
- x **DO NOT** use any tool or lever to turn the ram tommy bar, use hand effort only.
- x **DO NOT** hit workpiece, or ram, with a hammer if workpiece has not moved with maximum puller force applied. Use a larger capacity puller.
- ✓ Account for all tools and parts being used and do not leave them in or on the vehicle.

IMPORTANT: Always refer to the vehicle manufacturer's service instructions, or proprietary manual, to establish the correct procedure and data. These instructions for use are provided as a guide only.

4. INSTRUCTIONS FOR USE

- ❑ **WARNING! Ensure that you read, understand and apply the safety instructions in Section 3.**
- 3.1. Confirm that the workpiece is retained by interference fit (parallel or taper) only.
- 3.2. Assemble the appropriate puller, see fig.1, and adjust T-handle (fig. 2.A) so that the tommy bar (fig.2.B) is approximately 80mm (3") above top of ram, see fig.2.
- 3.3. Fit the puller claws behind the workpiece and then screw ram **body** down, with centre adaptor (item 4) over piston end, until centre adaptor point locates in end of shaft from which workpiece is to be pulled. If necessary use ram extension (item 5) to achieve this.

Note: Only use centre adaptor where end of shaft has a matching 'centre' machining.
- 3.4. Ensure puller is centrally positioned with respect to workpiece and shaft and then turn T-handle clockwise, by hand only, to pull workpiece from shaft.
- 3.5. Do not screw T-handle in further than 25mm (1") from end of the ram (see fig.2). If workpiece requires additional movement then unscrew T-handle to 80mm from end of ram, screw ram body down so that centre adaptor again contacts shaft and then continue to draw workpiece up shaft.

IMPORTANT: The maximum safe load for the puller can be achieved by hand effort alone. **The use of tools or levers on the tommy bar to increase the load will damage the puller and may result in injury.** Such misuse will also invalidate the warranty.
- ❑ **WARNING!** If the workpiece does not move when maximum puller force is applied, **DO NOT** hit it, or the puller, in an attempt to jar it free. Damage to puller/workpiece and personal injury may result. Use a larger capacity puller.

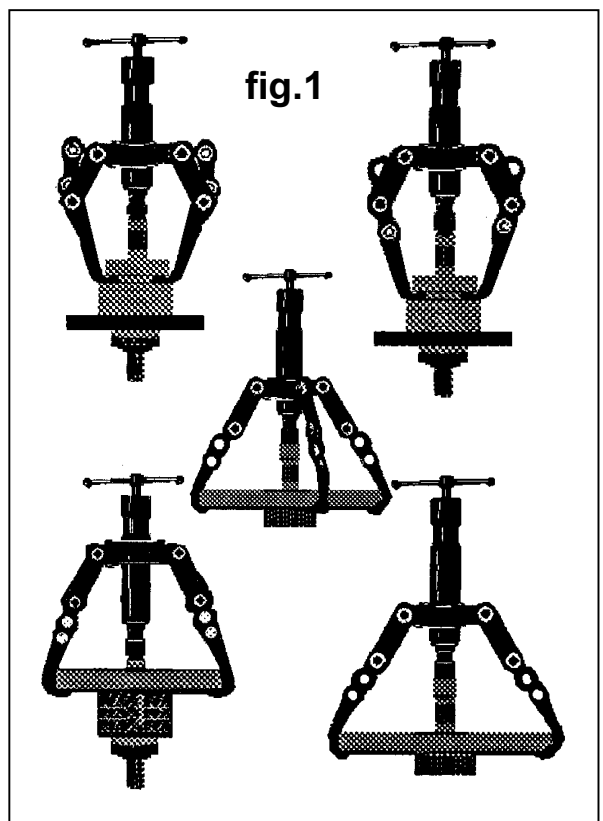
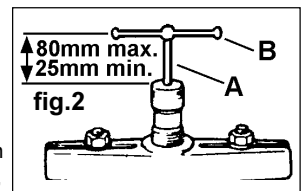

5. MAINTENANCE

5.1. GENERAL

- 5.1.1. Keep all items clean and lightly oiled. Keep all threads free from grit and lubricate the ram regularly.
- 5.1.2. Store the ram in the closed position to prevent piston surface corrosion.

5.2. TO CHANGE OIL IN RAM

IMPORTANT: The hydraulic system operates on a specially formulated oil which must be replaced from time to time.

Use Sealey Hydraulic Jack Oil, available from your authorised Sealey dealer. Quote model number:

HJO500MLS for 1 x 500ml bottle or PS982/OIL for 15grms of oil for a single refill.

WARNING! Use of any other oil in ram may cause ram to fail and will invalidate your warranty. Wear appropriate eye, face and hand protection.

- 5.2.1. Dismantle by removing the ram cover (fig.3.2) with soft jaw grips (fig.3.A) (body may have to be held in a soft jaw vice, ensure body thread is not damaged). *Caution! The cover is spring loaded, take care when removing.* Carefully remove components 2, 3, and 4 from the cylinder.
- 5.2.2. Screw T-handle (fig.4.5) down as far as it will go, then unscrew and remove it from the body (fig.4.5).
- 5.2.3. Push a narrow screw driver (fig.4.9), or a rod of appropriate diameter, down the small opening in head of ram (B), in order to push components 6, 7, and 8, plus the oil, out of the main cylinder. Note: A medium force may be required.
- 5.2.4. Remove remaining oil from main cylinder, clean all components

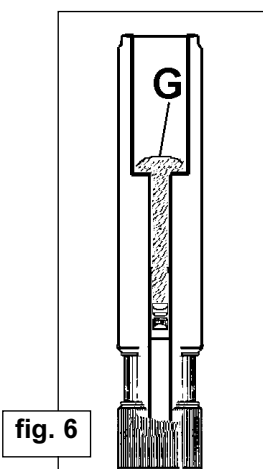
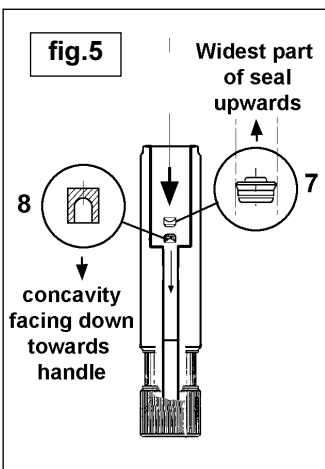
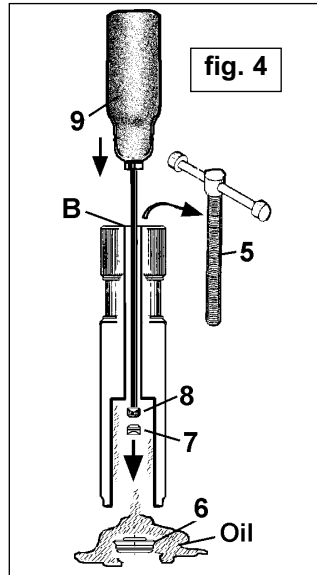
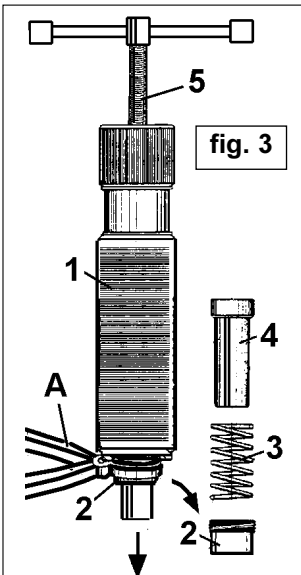

- 5.2.5. Take small seal and piston (fig.5.7 & 8) and gently push them down the narrow bore of the cylinder ensuring the metal piston (8) is first, with the concave face pointing in the direction of the T-handle, and the seal (fig.5.7) second, with the widest part of the seal facing upwards towards the main cylinder (fig.5). Push into bore as far as possible.
- 5.2.6. Pour 15grms of oil into the bore (fig.6). Insert larger seal (fig.7.6) as shown, with the widest part of the seal facing downwards into the bore. Push down into main cylinder as far as 'X' (fig.7) followed by piston (fig.7.4) and spring (fig.7.3).
- 5.2.7. Refit (do not overtighten) ram cover (fig.7.2) and replace T-handle (fig.7.5).
- WARNING!** The correct orientation of pistons and seals in the ram is critical.
- 5.2.8. Screw T-handle into ram until it contacts small piston and then turn a further two or three times.
- 5.2.9. Remove T-handle and firmly bounce the ram piston (fig.8) on a hard, but non-damaging, surface 6 to 10 times to consolidate the oil. Replace the T-handle, wipe clean and the ram is ready for use.

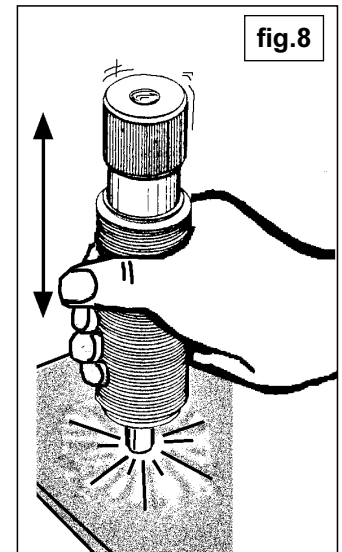
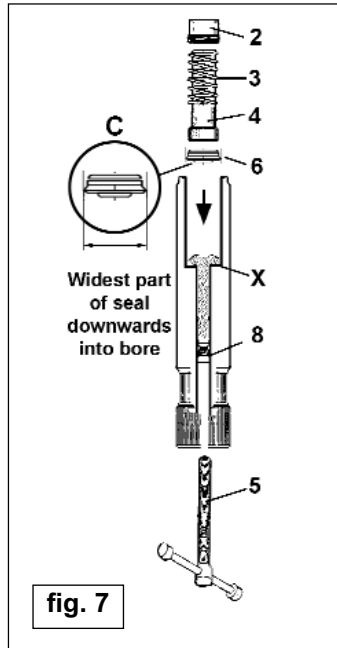

6. SERVICE PARTS & NOTES

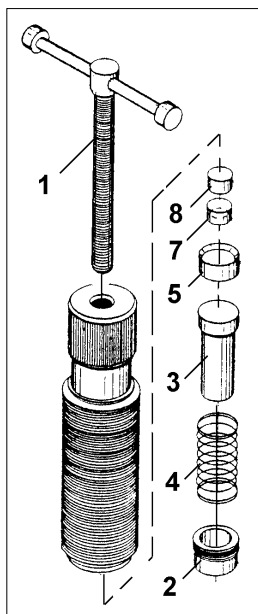

6.0. MAINTENANCE OF EARLY MODELS.

Please note that earlier models of the PS990 were filled with a hydraulic grease.

- WARNING!** Do not put oil into units previously filled with grease as the seals will be configured for grease only and will leak if used with oil.

6.1 CONVERTING OLD UNITS TO OIL

The old type grease filled PS990 can be converted for use with oil by replacing the internal components with those supplied in the repair kit shown on left Part No PS982/8002. Do not mix old and new components. A single 15grm refill of oil may be obtained by quoting Part No.PS982/OIL

NOTE: It is our policy to continually improve products and as such we reserve the right to alter data, specifications and component parts without prior notice.

IMPORTANT: No liability is accepted for incorrect use of this product.

WARRANTY: Guarantee is 12 months from purchase date, proof of which will be required for any claim.

INFORMATION: For a copy of our catalogue and latest promotions call us on 01284 757525 and leave your full name, address and postcode.



Sole UK Distributor
Sealey Group,
Bury St. Edmunds, Suffolk.

01284 757500
01284 703534

www.sealey.co.uk
sales@sealey.co.uk