



100MM 2-STROKE PETROL POST DRIVER

MODEL NO: PPD100

Thank you for purchasing a Sealey product. Manufactured to a high standard, this product will, if used according to these instructions, and properly maintained, give you years of trouble free performance.

IMPORTANT: PLEASE READ THESE INSTRUCTIONS CAREFULLY. NOTE THE SAFE OPERATIONAL REQUIREMENTS, WARNINGS & CAUTIONS. USE THE PRODUCT CORRECTLY AND WITH CARE FOR THE PURPOSE FOR WHICH IT IS INTENDED. FAILURE TO DO SO MAY CAUSE DAMAGE AND/OR PERSONAL INJURY AND WILL INVALIDATE THE WARRANTY. KEEP THESE INSTRUCTIONS SAFE FOR FUTURE USE.



Refer to instructions



Wear eye protection



Wear protective gloves



Wear safety footwear



Wear protective clothing



Wear ear protection



Hot surfaces

1. SAFETY

1.1. GENERAL SAFETY

- WARNING!** Stop the engine and disconnect the spark plug before changing accessories or performing any maintenance.
- WARNING! DO NOT** operate the driver if damaged. Replace or repair using recommended parts only. Unauthorised parts may be dangerous and will invalidate your warranty. Use authorised Service agent only.
- ✓ Keep the driver in good condition. Regular maintenance will give the best and safest performance.
- ✓ Wear appropriate PPE when using driver.
- ✗ **DO NOT** allow children or untrained persons to operate the driver. Children should be supervised to ensure that they **DO NOT** play with the machine.
- ✓ The machine can be used by people with reduced physical, sensory or mental capabilities or lack of experience and knowledge if they have been given supervision or instruction concerning use of the machine in a safe way and understand the hazards involved.
- ✗ **DO NOT** jam the operating trigger in the operating position and **DO NOT** pull the trigger without holding the driver firmly in both hands.
- ✗ **DO NOT** use the driver if you are tired or under the influence of alcohol, drugs or intoxicating medication.
- ✓ When not in use, disconnect the spark plug. Drain off any unused fuel into suitable container and dispose of according to local regulations. Clean and dry the driver and store in case.

1.2. ENGINE SAFETY

- WARNING!** Check the engine oil level before each start-up. Only use approved oil. Never operate the engine with insufficient oil.
- WARNING! DO NOT** touch spark plug or plug lead whilst the engine is running; severe, potentially fatal, electric shock may result.
- ✓ Ensure that only the correct fuel type and grade is used.
- ✗ **DO NOT** check ignition system by removing the spark plug or spark plug lead. Use specific tester or contact service agent.
- ✗ **DO NOT** operate the driver in an enclosed area as the motor exhaust fumes are a health hazard. Always ensure adequate ventilation.
- ✗ **DO NOT** leave the driver unattended whilst operating, and **DO NOT** remove the fuel cap whilst the engine is running.
- ✗ **DO NOT** refuel the engine whilst it is running. Stop the engine and allow it to cool for two minutes before attempting to refuel.
- ✗ **DO NOT** refuel in a closed or poorly ventilated environment as there is a danger of explosion or fire. Refuel outdoors only.
- ✗ **DO NOT** smoke or place the driver near any naked flames whilst re-fuelling.
- ✗ **DO NOT** operate driver if there is a fuel leak. Move the unit and avoid using until the leak has been fixed and the machine is dry.
- ✗ **DO NOT** start the engine if there are any flammable materials near the exhaust system or in the path of the exhaust gases.
- ✗ **DO NOT** block the engine ventilation grilles.
- ✓ Ensure engine fuel is stored in an approved container.
- ✓ For long term storage ensure the fuel is drained and that the driver is adequately protected against frost.
- ✗ **DO NOT** operate the engine with the air filter removed.
- ✗ **DO NOT** touch the engine during or after use. To avoid burns, allow it to cool before handling.

2. INTRODUCTION

Petrol powered post driver designed for use with fence posts up to 100mm width. 52cc Single cylinder engine with a fuel capacity of 1.3L. Includes additional sleeves for adjusting post sizes to 69mm and 49mm diameter. Engine is turned on via pull-start cord. Accessories include a mixing oil bottle, a small tub of grease and a small tool kit to make adjustments.

3. SPECIFICATION

Model No.:	PPD100
Engine Capacity:	52cc
Engine Power:	1.2HP
Engine Type:	2 Stroke Petrol
Fuel:	2 Stroke 25:1
Fuel Consumption:	0.6L/h
Fuel Tank:	1.3L
Vibration:	13.891m/s ²
Uncertainty:	1.5m/s ²

4. OPERATION

- NOTE:** Read and fully understand the safety instructions before using this driver.
- **WARNING:** Turn engine off, disconnect the spark plug and allow to cool before re-filling with fuel or making any adjustment.
- 4.1. Unscrew piling socket retainer and fit appropriate piling socket (fig.1). Refit retainer before use.
 - 4.2. When initially starting the engine from cold, prime the unit by depressing the priming bulb three or four times (fig.1).
 - 4.3. When the engine is started from cold for the first time, close the choke (fig.1).
 - 4.4. Sharply pull the starter pull cord (fig.1) to its extent and allow it to rewind gently under control. The engine should start after 2-4 pulls.
 - 4.5. When running, re-open the choke and allow to idle until running smoothly before using.
 - 4.6. Once running smoothly, squeeze the throttle lever to achieve the required speed.
 - 4.7. Optimum running speed is mid-range.
 - × **DO NOT** run engine at high speed when not being used as a driver.
 - 4.8. To turn the engine off, slide the engine cut off switch (fig.1) to the stop position. Reset switch after use or the engine will not fire.

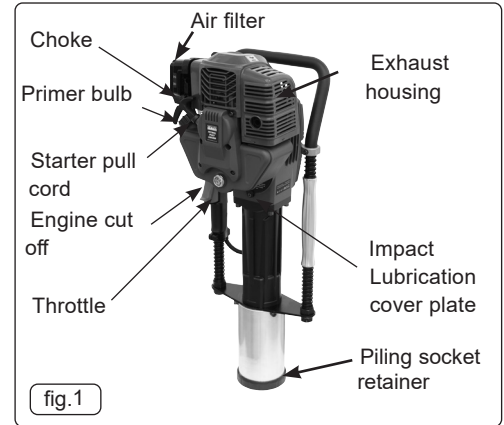

5. MAINTENANCE

- **WARNING:** Turn driver off and disengage the spark plug before cleaning, re-filling with fuel/grease, making any adjustment or replacing components.
- 5.1. **AIR FILTER**
 - 5.1.1. Unclip the filter housing (fig.1) and remove the filter.
 - 5.1.2. Clean filter using warm water and detergent. Dry thoroughly before replacing.
 - 5.2. **SPARK PLUG**
 - 5.2.1. Gently brush the carbon / sediment from tip of spark plug using a wire brush or emery paper.
 - 5.2.2. Gently clean the facing surfaces of the electrodes using very fine emery cloth or similar and set the gap between them to be 0.5 to 0.7mm wide.
 - 5.3. **IMPACT CYLINDER LUBRICATION**
 - 5.3.1. After 50 hours usage, remove impact lubrication hole plug (fig.1, fig.2) using hex key supplied.
 - 5.3.2. Top up level from lubricant tube and replace threaded plug when completed.
 - 5.4. **FUEL FILTER**
 - 5.4.1. If the fuel filter is blocked the engine will exhibit reduced performance. To clean the filter it is necessary to remove it from inside the fuel tank using a long wire hook to gently pull it out of the filler neck. Replace carefully once cleaned of debris / sludge.
 - 5.5. **GENERAL CLEANING**
 - 5.5.1. Brush off unit and exhaust housing to ensure adequate ventilation around the cylinder heat sink fins.
 - 5.6. **STORAGE**
 - 5.6.1. Store driver in the storage container provided.
 - 5.6.2. Clean and dry unit and empty fuel tank before storing.

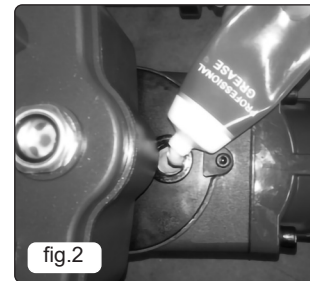

6. TROUBLESHOOTING

Symptom	Possible cause	Solution
Poor starting / poor running	Spark plug soiled	Clean spark plug (section 5.2)
	Fuel shortage, filter blocked	Top up / Clean See section 5.4
	Check choke position	See section 4.3
	Air filter clogged	See section 5.1



WEEE REGULATIONS

Dispose of this product at the end of its working life in compliance with the EU Directive on Waste Electrical and Electronic Equipment (WEEE). When the product is no longer required, it must be disposed of in an environmentally protective way. Contact your local solid waste authority for recycling information.



ENVIRONMENT PROTECTION

Recycle unwanted materials instead of disposing of them as waste. All tools, accessories and packaging should be sorted, taken to a recycling centre and disposed of in a manner which is compatible with the environment. When the product becomes completely unserviceable and requires disposal, drain any fluids (if applicable) into approved containers and dispose of the product and fluids according to local regulations.

Note: It is our policy to continually improve products and as such we reserve the right to alter data, specifications and component parts without prior notice.

Important: No Liability is accepted for incorrect use of this product.

Warranty: Guarantee is 12 months from purchase date, proof of which is required for any claim.

Sealey Group, Kempson Way, Suffolk Business Park, Bury St Edmunds, Suffolk. IP32 7AR



01284 757500



01284 703534



sales@sealey.co.uk



www.sealey.co.uk