



INSTRUCTIONS FOR:  
**PLASMA CUTTER**  
 Model: **PP40.**

Thank you for purchasing a Sealey plasma cutter. Manufactured to a high standard this product will, if used according to these instructions and properly maintained, give you years of trouble free performance.

**⚠ IMPORTANT: BEFORE USING THIS PRODUCT, PLEASE READ THE INSTRUCTIONS CAREFULLY. MAKE CAREFUL NOTE OF SAFETY INSTRUCTIONS, WARNINGS AND CAUTIONS. THIS PRODUCT SHOULD ONLY BE USED FOR ITS INTENDED PURPOSE. FAILURE TO DO SO MAY CAUSE DAMAGE OR PERSONAL INJURY, AND WILL INVALIDATE THE WARRANTY. RETAIN THESE INSTRUCTIONS FOR FUTURE USE.**

**1. INTRODUCTION & SPECIFICATIONS**

The plasma cutting system is operated by connecting the positive (+) clamp from the machine to the workpiece. The torch is positioned about 3mm above the surface of metal area to be cut. When the torch trigger is depressed a very high temperature produces a combined electrical arc, and fast flowing air to generate a plasma (a very hot gas) jet. The plasma transfers the electric arc to the metal workpiece which is melted by the heat jet at the point of contact. The torch is moved along cutting line until work is complete, and the workpiece is cut or divided accordingly.

The PP40 is an inverter power supply fitted with a plasma cutter control circuitry. Features include a 4 LED information panel including torch-under voltage, air fault, general fault (thermostat, over/under voltage, over current) and power on. The plasma inverter is suitable for cutting steel, stainless, aluminium and brass. Unit includes integrated air filter and regulator unit with panel mounted pressure gauge.

Duty cycle . . . . .35% @ 40 A  
 Air requirements . . . . .120 ltr/min  
 Air pressure . . . . .55-70 psi  
 Power Efficiency . . . . .5.2 Kva  
 Mains Voltage . . . . .230V - 1 ph  
 Insulation class . . . . .H  
 Electrical protection . . . . .Class 1  
 Weight . . . . .14 Kg  
**INPUT**  
 Absorbed current . . . . . 15.4A 32.5  
 Power factor . . . . .(cosphi) 0.65 - 0.72  
 Delayed fuses . . . . .20A

**OUTPUT**  
 No load Voltage . . . . .370V  
 Rated cutting Voltage . . . . .86-96V  
 Rated cutting current . . . . .15-40A  
**PLASMA TORCH**  
 Gas . . . . .DRY compressed air  
 Air pressure . . . . .55-70psi  
 Cooling flow rate . . . . .120 lt/min  
 Striking system . . . . .HF & Pilot Arc  
 cutting current . . . . .15 by 40A  
 Max cutting thickness . . . . .12 mm

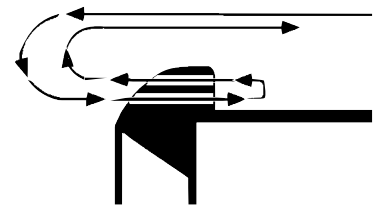

**2. SAFETY INSTRUCTIONS**

**2.1. ELECTRICAL SAFETY. ⚠ WARNING! Electrical installation of the plasma cutting unit must only be carried out by a qualified electrician. Make sure that power supply cable is correctly connected to Earth Plate. It is the user's responsibility to read, understand and comply with the following:**

You must check all electrical equipment and appliances to ensure they are safe before using. You must inspect power supply leads, plugs and all electrical connections for wear and damage. You must ensure the risk of electric shock is minimised by the installation of appropriate safety devices. An RCCB (Residual Current Circuit Breaker) should be incorporated in the main distribution board. We also recommend that an RCD (Residual Current Device) is used with all electrical products. It is particularly important to use an RCD together with portable products that are plugged into an electrical supply not protected by an RCCB. If in doubt consult a professional electrician. You may obtain a Residual Current Device by contacting your Sealey dealer. **You must** also read and understand the following instructions concerning electrical safety.

- 2.1.1. The **Electricity At Work Act 1989** requires all portable electrical appliances, if used on a business premises, to be tested by a qualified Electrician at least once a year by using a Portable Appliance Tester (PAT).
- 2.1.2. The **Health & Safety at Work Act 1974** makes owners of electrical appliances responsible for the safe condition of the appliance, and safety of the appliance operator. **If in any doubt about electrical safety, contact a qualified electrician.**
- 2.1.3. Ensure the insulation on all cables and the product itself is safe before connecting to the mains power supply. See 2.1.1. & 2.1.2. above and use a Portable Appliance Tester (PAT).
- 2.1.4. Ensure that cables are always protected against short circuit and overload.
- 2.1.5. Regularly inspect power supply, leads, plugs and all electrical connections for wear and damage, especially power connections, to ensure that none are loose.
- 2.1.6. **Important:** Ensure the voltage marked on the product is the same as the electrical power supply to be used, and check that plugs are fitted with the correct capacity fuse. A 13Amp plug may require a fuse smaller than 13Amps for certain products (**subject to 2.1.11. below**) see fuse rating at right.
- 2.1.7. DO NOT pull or carry the powered appliance by its power supply lead. Products such as welders must not be pulled or carried by their output cables.
- 2.1.8. DO NOT pull power plugs from sockets by the power cable.
- 2.1.9. DO NOT use worn or damage leads, plugs or connections. Immediately replace or have repaired by a qualified Electrician.
- 2.1.10. DO NOT use this product with a cable extension reel.
- 2.1.11. **This product will require MORE than a 13Amp electrical supply, so no plug will be fitted. You must contact a qualified Electrician to ensure a 30 Amp fused supply is available. We recommend you discuss the installation of a industrial round pin plug & socket with your electrician.**

**FUSE RATING**  
 TO GAIN MAXIMUM  
 OUTPUT THE PLASMA  
 CUTTER MUST BE  
 CONNECT TO A  
**30 Amp FUSED**  
 ELECTRICAL SUPPLY

**⚠ WARNING! Reminder, the electrical installation of the plasma cutting unit must only be carried out by a qualified electrician. Make sure that power supply cable is correctly connected to Earth Plate.**

## 2.2 GENERAL SAFETY

- ▲ **DANGER!** Direct contact with the plasma cutter circuit or torch is dangerous. You **MUST** unplug the cutter from the mains power supply, (and the compressed air supply) before connecting or disconnecting cables or performing maintenance or service.
- ✓ Keep the plasma cutter, cables and torch in good working order and condition. (Take immediate action to repair or replace damaged parts).
- ✓ Use recommended parts and accessories only. (Non recommended parts may be dangerous and will invalidate the warranty).
- ✓ Only use the cutting torch provided with the system, and ensure any replacement is of the same type.
- ✓ Use the plasma cutter in an adequate working area for its function. Ensure the area has adequate ventilation as welding fumes are harmful. For enclosed areas we recommend the use of an air and smoke extraction system. If you are not able to provide adequate extraction and/or ventilation, wear a respirator suitable for protection against toxic fumes, smoke, and gases.
- ✓ Ensure there are no obstructions to the flow of clean cool air and ensure there is no conductive dusts, corrosive vapours or humidity which could enter the unit and cause serious damage.
- **WARNING:** use a welding head shield to protect your eyes and avoid exposing skin to the ultraviolet rays given off by the electric arc. Always wear protective clothing, insulating gloves and shoes. Keep all protective items clean and undamaged.
- ✓ Remove ill fitting clothing before wearing protective clothing, also remove ties, watches, rings, and other loose jewellery, and contain long hair.
- ✓ Stand correctly keeping a good footing and balance, and ensure the floor is not slippery, and wear non-slip shoes.
- ✓ Ensure the workpiece is correctly secured before operating the plasma cutter.
- ✓ Avoid unintentional contact with workpiece. Accidental or uncontrolled switching on of the torch may be dangerous and will wear the nozzle.
- ✓ Keep unauthorised persons away from the working area, and any persons working within the area must adorn the same protective items.
- ✗ DO NOT use cables and torch if the insulation is worn or connections are loose.
- ✗ DO NOT attempt to fit any non authorised torches, components, or parts to the plasma cutting unit.
- ✗ DO NOT cut surfaces that are painted, galvanic coated, oily or greasy.
- ✗ DO NOT use cables over 10m in length.
- ✗ DO NOT use any metallic structure which is not part of the work piece to substitute the return cable of the plasma current.
- ✗ DO NOT hit the electrode on the workpiece, this may damage the electrode and make strike-up difficult.
- ▲ **DANGER!** DO NOT cut near inflammable materials, solids, liquids, or gases. Remove all flammable materials such as waste rags etc.
- ✗ DO NOT cut containers or pipes which have held flammable materials or gases, liquids or solids. DO NOT cut materials that have been cleaned with chlorinated solvents (or near such solvents) as vapours from the arc action may produce toxic gases.
- ✗ DO NOT operate cutter while under the influence of drugs, alcohol or intoxicating medication, or if fatigued.
- ✗ DO NOT force the plasma cutter to achieve a task it was not designed to perform.
- ✗ DO NOT operate the plasma cutter if any parts are damaged or missing as this may cause failure or possible personal injury.
- ✗ DO NOT carry, or pull cutter by leads or cables. DO NOT strain or bend cables, protect from sharp or abrasive items, DO NOT stand on cables or leads. Protect from heat. Long lengths of slack must be gathered & neatly coiled. DO NOT place cables where they endanger others.
- ✗ DO NOT hold unsecured work in your hand.
- ✗ DO NOT get the plasma cutter wet or use in damp or wet locations or areas where there is condensation.
- ✗ DO NOT use cutter where there is flammable liquids, solids or gases such as paint solvents, including waste wiping or cleaning rags etc.
- ✗ DO NOT touch the workpiece close to the cut as it will be very hot. Allow to cool. The cut edge of the workpiece will also be very sharp.
- ✗ DO NOT touch the torch immediately after use. Allow the torch to cool.
- ✓ When not in use store the unit in a safe, dry, childproof area.

## 2.3 AIR SUPPLY GENERAL SAFETY

- **WARNING!** turn off air supply and de-pressurise the air before removing the pump unit from the plasma system. Failure to comply with this instruction may damage the unit and will invalidate your warranty.
- **WARNING!** ensure correct air pressure is maintained and not exceeded. Recommended pressure 55-70psi required air flow 120lt./min.
- **WARNING!** DO NOT exceed maximum entry pressure of 90psi. Excessive pressure may cause possible damage and/or personal injury.
- ✓ Keep air hose away from heat, oil and sharp edges. Check air hose for wear before each use, and ensure that all connections are secure.
- ✗ DO NOT carry the cutter by the hose, or yank the hose from the air supply, and DO NOT direct air from the air hose at yourself or others.
- **WARNING!** turn off air supply and de-pressurise the control nozzle before removing the pump unit from any installation or mobile system. Failure to comply with this instruction may damage the unit and will invalidate your warranty.

## 3. CARRY STRAP ASSEMBLY

If not already fitted, follow the carrying strap assembly as pictured to the right.

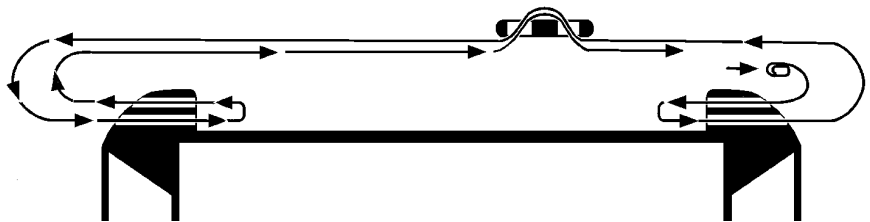

## 4. AIR SUPPLY

- **WARNING!** Ensure you have read and understood the safety instructions in 2.3. before connecting or operating the air supply.
- 4.1. An external compressed air supply must be attached to the plasma cutter. The supply must produce a minimum of 55-70psi with a capacity of 120 L/min for operating unit. The maximum entry pressure into the unit however must not exceed 90psi.
- 4.2. To avoid excessive wear of the cutter ensure the air supply is clean and free from moisture. We recommend the fitting of a clean air filtration unit as pictured in fig 1 with connection procedure. Alternatively attach a filter unit immediately at the rear of the plasma cutter fig 1.
- 4.3. The air inlet filter system should be cleaned weekly.
- 4.4. Line pressure should be increased to compensate for unusually long air hoses (over 8 metres). The minimum hose diameter should be 10mm I.D. and fittings must have the same inside dimensions.
- 4.5. Keep hose away from heat, oil and sharp edges. Check hoses for wear, and make certain that all connections are secure.

**Note:** DO NOT use oiler with the air system, the air must remain DRY at all times.

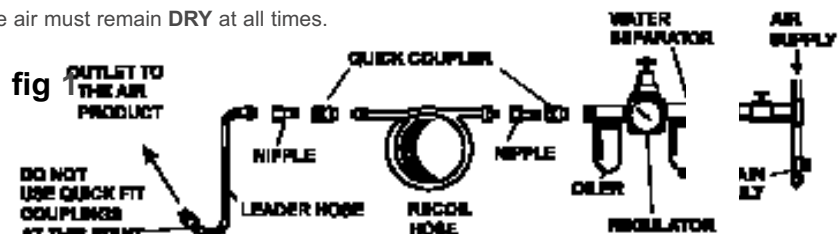
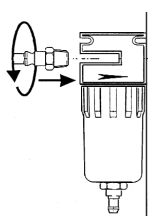

## 5. CONTROL INSTRUCTIONS

❑ **WARNING!** before operating the machine ensure that you have read, understand and apply chapter 2 safety instructions. Ensure the machine is disconnected from the power supply before moving or changing accessories.

### 5.1. Locating the Machine.

- 5.1.1. Ensure your work area has a good airflow and that there is no dust, smoke or gas present.
- 5.1.2. Ensure that there is a minimum clearance of 500mm around the machine, and there are no obstacles to prevent a cool air flow. Also check to ensure the front outlet and rear inlet grills are not blocked.
- 5.1.3. When moving the machine disconnect the unit from the mains power supply, and gather all cables safely.

### 5.2. Connecting the Earth cable.

Connect the work cable clamp to the piece to be cut or to the metallic workbench as follows:

- 5.2.1. Check that there is a good electrical contact. Caution: Ensure you have made good contact on oxidised or insulate coated sheets.
- 5.2.2. Make the Earth connection as close to the cutting area as possible.
- 5.2.3. DO NOT use metallic structures or objects to make contact (i.e. return cable), other than the metallic workbench which is holding workpiece. To do so may endanger the system safety and will give a poor cut result. DO NOT make Earth connection to the off cut, or piece that will be removed.

### 5.3. Connecting the Plasma Cutter.

- 5.3.1. Insert the male connector of the torch into the centralised connector on the front panel of the machine. Check to ensure the polarisation keys match.
- 5.3.2. Screw the ring nut tightly clockwise to ensure air flow without leaks.
- 5.3.3. Before cutting, check the head of the torch to ensure it is correctly assembled.

### 5.4. ON / OFF Switch.

The on/off switch is located at the rear of the machine (fig 3.1). When the switch is in the "O" position the machine is turned off. When switched to the "I" position the machine is turned on, which will be indicated by two green lights. One light being the ready indicator, and the other confirmation that the mains power is on. When switched on, the machine control and duty circuits are live but the torch will remain in a "Stand-By" mode until the torch button is pressed.

### 5.5. The Cutting Regulator.

The cutting current is regulated by switch (fig 2.2 & fig 4). This switch regulates the supply of current required to cut various thickness of metal at various speeds according to the machines technical data.

### 5.6. Air Pressure Gauge

- 5.6.1. Check torch and view technical data to determine what pressure you will require.
- 5.6.2. Pull and turn the pressure regulator knob "ON" (fig 3.3). Flick switch (fig 2.9) down and read pressure gauge (4) to check when the required "psi" value is registered.
- 5.6.3. Push the pressure regulator knob to lock it.

### 5.7. The Torch Control.

When the machine is turned on the green indicator light will show that the torch is in a "Stand-By" mode.

- 5.7.1. Press the torch button to activate and note the pilot arc on signal is displayed by a yellow light (fig 2.5).
- 5.7.2. As a safety feature, should the following situations arise the torch will automatically de-activate.
  - a) During PREAIR (0.3s) and POSTAIR (>30s) phases.
  - b) If the pilot arc is not moved to the workpiece within 2 seconds.
  - c) If the cutting arc is interrupted because it is held too far from the torch-part, or the electrode is worn out, or the torch has been forced away from the workpiece.
  - d) Should the alarm security switch activate (see fig 3.8).

### 5.8. The Thermal Switch & Mains Voltage Fault.

If the thermal, and mains fault switch illuminates as a RED LED and an alarm sounds, this will indicate one of the following:

- a) The power transformer has overheated.
  - b) There has been a decrease or increase in the mains voltage power supplied to the machine.
- The activation of this switch is automatic and will stop the all functions.

The problem that had caused this switch to activate is self rectifying, and within a few seconds the switch will re-set and the RED LED light will go out. The machine is now ready to use once again.

### 5.9. Air Pressure Fault Signal.

If YELLOW LED together with the RED LED, (fig 2. 6 & 7), and alarm activate, this will indicate that air pressure is too great or too low. This activation will automatically stop the machine operating.

Make any necessary adjustments to the air pressure.

Once the air pressure is correct the fault signal will return to normal, the LED displays will go out, and the machine is ready to use again.

### 5.10. Technical Data.

On the rear of the machine you will find technical data as follows:

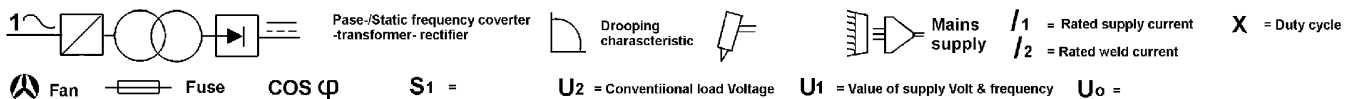

### 5.11. The Torch

Although the machine and torch may be fully powered, the torch button is the only device that will activate the cutting process.

- 5.11.1. To turn the cutting process on, the torch button must be fully depressed
- 5.11.2. Release the button and the cutting cycle will stop immediately. The cooling air (post-air) will continue to function.

**NOTE:** To minimise the possibility of accidental starting, the on button must be pushed to at least 300ms before the cutting operation will start.

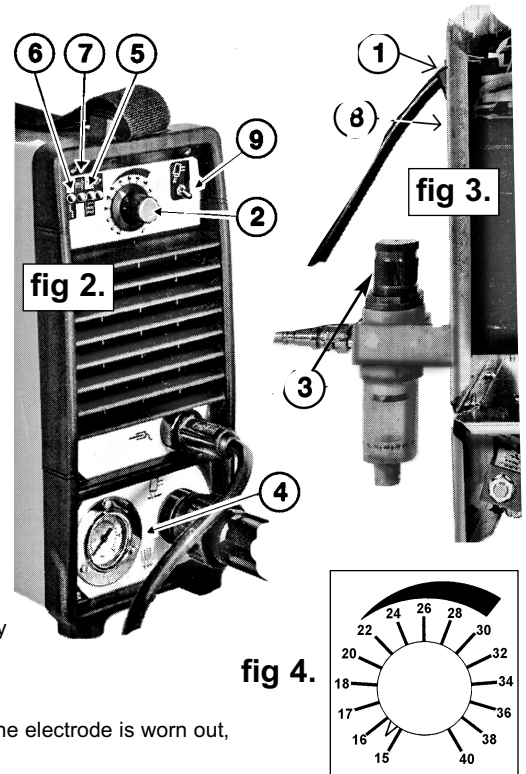

## 6. OPERATING INSTRUCTIONS

❑ **WARNING!** before operating the machine ensure that you have read, understand and apply chapter 2 safety instruction, and that you have familiarised yourself with the controls. Ensure the machine is disconnected from the power supply before moving or changing accessories.

### 6.1. Set up

- 6.1.1. Ensure you have the compressed air connected correctly to the machine. (see chapter 4).
- 6.1.2. Check that the Earth cable is correctly clamped to the piece to be cut as (see chapter 5).
- 6.1.3. Switch on the mains power supply and the machine "on" switch (turn switch in fig 3.1. to the "I" position).
- 6.1.4. Set the regulator switch the the appropriate position for the task to be performed (fig 4).
- 6.1.5. Press the torch button to commence the flow of cooling air (post-air).
- 6.1.6. Check the torch technical data and set the air pressure until the air gauge (fig 2. 4) indicates the correct value.
- 6.1.7. Allow the air flow to continue until any condensation has been removed from the torch. At this point the air flow should automatically stop.

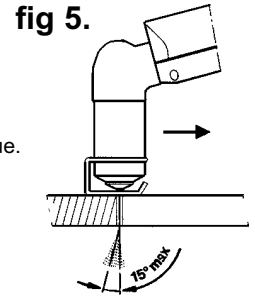

### 6.2. Cutting workpiece beginning from the edge.

The torch provided with this unit can actually make contact with the material to be cut (touch-cut). For cutting light materials however, a spacer (fig 9), has been provided, which prolongs the life of the electrode and nozzle. **NOTE: If the unit is being used over 30Amps, the spacer MUST be removed.**

- 6.2.1. Bring the torch nozzle toward the edge of workpiece and hold it at 3mm above the cutting line.
- 6.2.2. Press the torch button on. Pre-air will generate immediately igniting the pilot arc (after about 2 seconds). If the distance between the torch nozzle and the workpiece is correct, the arc will jump to the cutting line thereby commencing the cutting process.
- 6.2.3. Move torch slowly and smoothly forward along the cutting line at a consistent height from workpiece.
- 6.2.4. Adjust cutting speed according to the thickness of the material to be cut, and the selected current.
- 6.2.5. Check the underside of material being cut. The arc (flame) should have a 5 - 10° tilt (fig 5).

### 6.3. Cutting workpiece by piercing item.

- 6.3.1. Place torch nozzle at the maximum bracket angle to the position you wish to commence cutting (fig 6).
- 6.3.2. Ignite the torch arc, then slowly and smoothly bring the arc to the upright position.

### 6.4. To stop the arc.

- 6.4.1. Release torch button to stop the arc. The post-air will continue to flow cooling the nozzle.
- 6.4.2. Other reasons why the arc will stop operating are:
  - a) If the distance between the torch nozzle and workpiece is too great.
  - b) If you have completed a cut and have continued beyond the edge of a workpiece.
  - c) The waste cut off falls away from the workpiece thus increasing the gap.

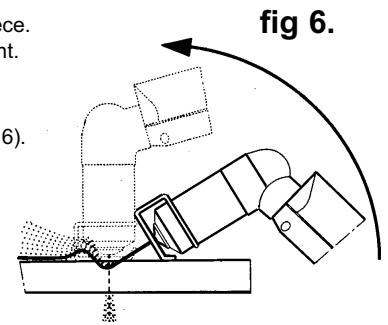

## 7. MAINTENANCE

▲ **DANGER!** Ensure machine is disconnected from power supply before performing service or maintenance on any part of the unit, cables or torch.

### 7.1. The power unit.

DO NOT open the machine. Service and maintenance of the machine must only be undertaken by an authorised service agent.

- 7.1.1. Keep the machine clean by wiping with a soft cloth. Do not use abrasives.
- 7.1.2. Periodically check to ensure the carrying handle is in good order and condition. If not replace it immediately.
- 7.1.3. Ensure that the front and rear air vents are not blocked.

### 7.2. Cables, and leads.

- 7.2.1. Check to ensure cables and leads are in good order and condition. If damaged contact your authorised service agent.
- 7.2.2. Keep cables and leads clean. Do not use solvents.

### 7.3. Torch.

Check torch regularly. Maintenance will depend on frequency and type of usage and is essential for correct and safe use of torch.

- ❑ **WARNING!** Ensure the torch is cool before attempting any maintenance. Always re-assemble the torch in the correct order ensuring that electrode, distributing ring and nozzle, before the nozzle holder. Never use tools to tighten nozzle components, hand tighten only. Manually dismantle the torch nozzle head (fig 7). Items 3A and 5A are optional extension nozzles.

- 7.3.1. Nozzle holder. (fig 7 item 2). Clean nozzle holder and check to ensure it is not damaged, (including distortion, burns, or cracks) if in any doubt replace the item.
- 7.3.2. Nozzle. (fig 7 item 3 & 3A). If surface is oxidised clean it with extra fine abrasive paper. Check wear of the plasma arc hole and the inner and outer surfaces. If hole has widened, or nozzle is damaged in any way replace it immediately. The nozzle "V" crater should be 2mm in depth (fig 8).
- 7.3.3. Air Distributing Ring (fig 7 item 4). Check that the ring is not burned or cracked and that the airflow holes are not obstructed. If damaged replace immediately.
- 7.3.4. Electrode. (fig 7 item 5 & 5A). Check the build up on the emitting surface of the electrode. When the build up is approximately 2mm replace the electrode. **NOTE:** We recommend that the electrode and nozzle should be changed at the same time.
- 7.3.5. Spacer. (fig 7 item 1, & fig 9). The spacer (fig 9) must be replaced if distorted or coated by scoria and is impossible to keep the torch in the correct position.

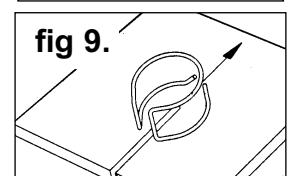
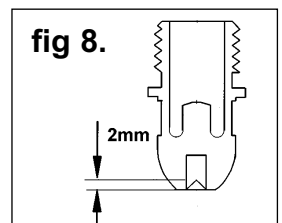
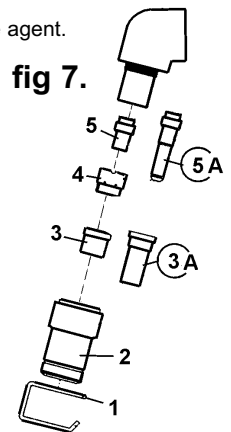

### 7.4. Compressed Air filter.

The filter (fig 1) drains condensation from the air system, and must be kept clean.

- 7.4.1. Regularly inspect the filter. If the glass bowl contains water, drain by pushing the drain plug upwards.
- 7.4.2. When the filter cartridge becomes dirty replace immediately.
- 7.4.3. Clean the filter with clean soapy water only. Do not use abrasives, or solvents.

## 8. TROUBLESHOOTING

PROBLEM	POSSIBLE CAUSE	REMEDY <i>(Numbers refer to chapter and item heading)</i>
Insufficient penetration or excessive scoria settlement.	Too high a cutting speed. Torch is too tilted. Workpiece is too thick. Electrode and nozzle are worn out.	Slow the cutting speed Adjust the torch tilt. Confirm workpiece thickness, and re-check technical data. Replace electrode and nozzle.
Interruption of cutting arc.	Cutting speed too low. Excessive distance between torch and workpiece. Electrode is worn out. Intervention of the protections system.	Increase cutting speed. Decrease the distance between torch and workpiece. Replace electrode and nozzle. Check warning lights and take appropriate action.
The torch is cutting at tilt when you wish it to be perpendicular.	Torch position not correct. Asymmetric wear of nozzle hole and/or wrong assembly of torch parts.	Re-align the torch position. Check assembly (see fig 9) and change nozzle if necessary.
Excessive wear of nozzle and electrode.	Air pressure too low. Contaminated air (humidity-oil). Excessive pilot arc ignitions in the air. Nozzle holder damaged.	Increase air pressure (see chapter 5). Check air supply system (see chapters 4, 5, & 7). Do not casually turn the torch on and off. Change the nozzle holder.

**Declaration of Conformity** We, the sole importer into the UK, declare that the product listed below is in conformity with the following EEC standards and directives.

**PLASMER CUTTER Model: PP40.**

73.23/EEC  
Low Voltage Directive (S.I. 1994/3260)  
89/336/EEC  
EMC Directive (S.I. 1992/2372 & Amendments).



The construction file for this product is held by the Manufacturer and may be inspected on request by contacting Jack Sealey Ltd

Signed by John Sealey

1st March 1999

*For Jack Sealey Ltd. Sole importer into the UK of Sealey Power Welders*

**NOTE:** It is our policy to continually improve products and as such we reserve the right to alter data, specifications and component parts without prior notice.

**IMPORTANT:** No liability is accepted for incorrect use of this equipment

**WARRANTY:** Guarantee is 12 months from purchase date, proof of which will be required for any claim.

**INFORMATION:** Call us for a copy of our latest catalogue on 01284 757525 and leave your full name and address including your postcode.

**SEALEY POWER WELDERS**

**Sole UK Distributor**  
**Sealey Group,**  
Bury St. Edmunds, Suffolk.



01284 757500



01284 703534

**E-mail:** sales@sealey.co.uk