

Thank you for purchasing a Sealey product. Manufactured to a high standard this product will, if used according to these instructions and properly maintained, give you years of trouble free performance.

IMPORTANT: PLEASE READ THESE INSTRUCTIONS CAREFULLY. NOTE THE SAFE OPERATIONAL REQUIREMENTS, WARNINGS AND CAUTIONS. USE THE PRODUCT CORRECTLY AND WITH CARE FOR THE PURPOSE FOR WHICH IT IS INTENDED. FAILURE TO DO SO MAY CAUSE DAMAGE AND/OR PERSONAL INJURY AND WILL INVALIDATE THE WARRANTY. PLEASE KEEP INSTRUCTIONS SAFE FOR FUTURE USE.

1. SAFETY INSTRUCTIONS

1.1. ELECTRICAL SAFETY

WARNING! It is the responsibility of the owner and the operator to read, understand and comply with the following: You must check all electrical products, before use, to ensure that they are safe. You must inspect power cables, plugs, sockets and any other connectors for wear or damage. You must ensure that the risk of electric shock is minimised by the installation of appropriate safety devices. A Residual Current Circuit Breaker (RCCB) should be incorporated in the main distribution board. We also recommend that a Residual Current Device (RCD) is used. It is particularly important to use an RCD with portable products that are plugged into a supply which is not protected by an RCCB. If in any doubt consult a qualified electrician. You may obtain a Residual Current Device by contacting your Sealey dealer. **You must** also read and understand the following instructions concerning electrical safety.

- 1.1.1. The **Electricity at Work Act 1989** requires that all portable electrical appliances, if used on business premises, are tested by a qualified electrician, using a Portable Appliance Tester (PAT), at least once a year.
- 1.1.2. The **Health & Safety at Work Act 1974** makes owners of electrical appliances responsible for the safe condition of those appliances and the safety of the appliance operators. **If in any doubt about electrical safety, contact a qualified electrician.**
- 1.1.3. Ensure that the insulation on all cables and on the appliance is safe before connecting it to the power supply. See 1.1.1. and 1.1.2. and use a Portable Appliance Tester.
- 1.1.4. Ensure that cables are always protected against short circuit and overload.
- 1.1.5. Regularly inspect power supply cables and plugs for wear or damage and check all connections to ensure that none is loose.
- 1.1.6. **Important:** Ensure that the voltage marked on the appliance matches the power supply to be used and that the plug is fitted with the correct fuse - see fuse rating at right.
- 1.1.7. **DO NOT** pull or carry the appliance by the power cable.
- 1.1.8. **DO NOT** pull the plug from the socket by the cable.
- 1.1.9. **DO NOT** use worn or damaged cables, plugs or connectors. Immediately have any faulty item repaired or replaced by a qualified electrician. When a BS 1363/A UK 3 pin plug is damaged, cut the cable just above the plug and **dispose of the plug safely.**

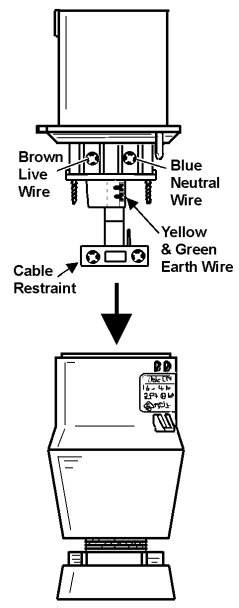
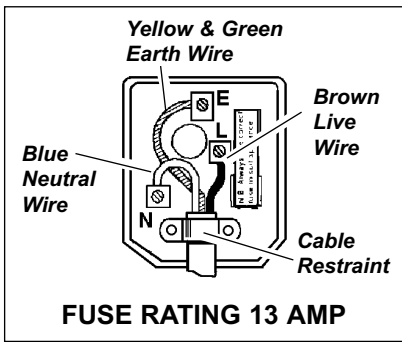

- a) **Connect the GREEN/YELLOW earth wire to the earth terminal 'E'.**
 - b) **Connect the BROWN live wire to the live terminal 'L'.**
 - c) **Connect the BLUE neutral wire to the neutral terminal 'N'.**
 - d) **After wiring, check that there are no bare wires, that all wires have been correctly connected, that the cable outer insulation extends beyond the cable restraint and that the restraint is tight.**
- Double insulated products, which are always marked with this symbol , are fitted with live (brown) and neutral (blue) wires only. To rewire, connect the wires as indicated above - **DO NOT** connect either wire to the earth terminal.
- 1.1.10. Products which require more than 13 amps are supplied without a plug. In this case you must contact a qualified electrician to ensure that a suitably rated supply is available. We recommend that you discuss the installation of an industrial round pin plug and socket with your electrician.
 - 1.1.11. If an extension reel is used it should be fully unwound before connection. A reel with an RCD fitted is preferred since any appliance plugged into it will be protected. The cable core section is important and should be at least 1.5mm², but to be absolutely sure that the capacity of the reel is suitable for this product and for others which may be used in the other output sockets, we recommend the use of 2.5mm² section cable.

1.2. GENERAL SAFETY

- WARNING! Ensure Health & Safety, local authority, and general workshop practice regulations are adhered to when using this equipment.**
- ✓ Familiarise yourself with the application, limitations and potential hazards of the hoist.
- WARNING! Disconnect the hoist from the mains power before changing accessories, servicing or performing any maintenance.**
- ✓ Maintain the hoist in good condition (use an authorised service agent).
- ✓ Replace or repair damaged parts. *Use genuine parts only. Unauthorised parts may be dangerous and will invalidate the warranty.*
- ✓ Locate hoist in a suitable work area, keep area clean and tidy and free from unrelated materials. Ensure that there is adequate lighting.
- WARNING! Ensure that the mounting for the hoist is capable of supporting at least 400kg without failure and that the hoist is mounted horizontally.**
- ✓ Keep the hoist clean for best and safest performance and check moving parts alignment regularly.
- ✓ Remove ill fitting clothing. Remove ties, watches, rings and other loose jewellery and contain and/or tie back long hair.
- ✓ Keep children and unauthorised persons away from the work area.
- ✓ Ensure the load is correctly secured before operating the hoist.
- x **DO NOT** use the hoist for any purpose other than that for which it is designed.
- x **DO NOT** operate the hoist if any parts are damaged or missing as this may cause failure and/or possible personal injury.
- x **DO NOT** exceed the rated capacity of the hoist.
- x **DO NOT** adjust or tamper with the maximum lift cut-out mechanism.
- x **DO NOT** use the hoist out of doors.
- x **DO NOT** get the hoist wet or use in damp or wet locations or areas where there is condensation.

- x DO NOT allow untrained persons to operate the hoist.
- x DO NOT operate the hoist when you are tired or under the influence of alcohol, drugs or intoxicating medication.
- x DO NOT use the hoist where there are flammable liquids, solids or gases such as paint solvents, etc.
- x DO NOT attempt to lift angled loads or to drag loads with the hoist. The centre of gravity of the load must always be directly below the hoist.
- x DO NOT allow the load to swing beneath the hoist.
- x DO NOT allow a raised and supported load to fall and thus shock load the mounting, hoist, cable and hook.
- x DO NOT use more than one hoist to lift a load.
- x DO NOT leave the hoist unattended with a suspended load.
- x DO NOT wrap the hoist cable around the load.
- x DO NOT use the hoist to lift dangerous materials.
- x DO NOT use the hoist to lift people.
- ✓ Use a qualified person to lubricate and maintain the hoist.
- ✓ When not in use and before carrying out repairs/maintenance isolate the hoist from the power supply.
- ▲ **DANGER! Ensure that personnel are prevented from passing beneath the hoist and load.**

2. INTRODUCTION & SPECIFICATIONS

The PH250.V2 and PH250/110 Power Hoists are for use where a suitable support exists. Each has a single line lift capacity of 125kg and a double line lift capacity of 250kg.

Specifications

Lifting capacity - single line	...125kg
	double line ...250kg
Lift height - single line	...11m
	double line ...5.5m

Cable diameter	...3mm
Cable breaking load	...900kg
Motor - PH250.V2	...230V 242W
Motor - PH250/110	...110V 242W

3. MOUNTING

- 3.1. Unpack the hoist and check contents against the items listed below. Should there be any damaged or missing parts contact your supplier immediately.
Items
 1. Hoist assembly
 2. Double line pulley and hook (loosely assembled)
 3. Bag containing mounting brackets (2) and screws (4)
- 3.2. Ensure that the selected support is sufficiently strong and will also hold the hoist in a horizontal position. If alternative mounting brackets are fabricated ensure that these are at least as strong as those provided and align with the mounting holes (fig.2 A) in the hoist.
- 3.3. Once the hoist is attached to the mount, connect cable (fig.1.1) to a switched power supply using either a junction box or an in-line plug and socket (plug is not supplied).

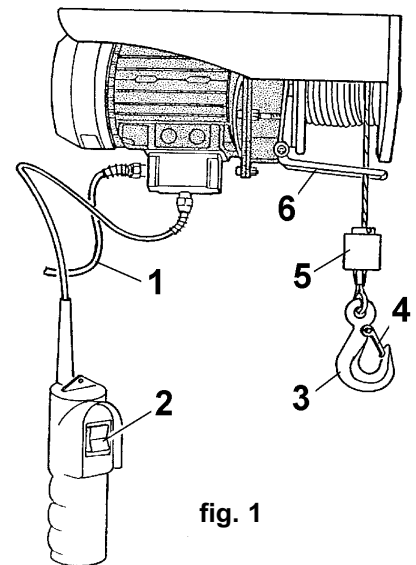

fig. 1

4. OPERATION

- **WARNING! Before using the hoist ensure that you have read, understood and apply the safety instructions in Section 1.**
- 4.1. Ensure that the load to be lifted is directly below the hoist and that any lifting straps, ropes or chains being used are capable of supporting the weight.
- 4.2. With mains power switched on, operate control switch (fig.1.2) to bring hook to load height. Press lower half of switch to lower hook and upper half to raise hook. Release switch to stop hoist.
- 4.3. Attach hoist hook (fig.1.3) to load ensuring that safety bar (fig.1.4) is fully closed.
- 4.4. Use control switch to raise or lower the load to the required height.
- 4.5. To carry out a double line lift first place single line hook in aperture in hoist frame (fig.2.B). Then take double line pulley and hook, remove nut and bolt holding hook and place pulley on cable loop between hoist drum and single line hook (fig.2.C). Refit hook and tighten both locknuts (fig.2.D), ensuring that pulley is free to rotate. Proceed as 4.2. to 4.4.

- Notes:**
1. It is important not to completely empty the cable drum and therefore the cable has a marker to indicate maximum cable length. DO NOT allow this marker to move significantly below the cut-out arm (see fig.3).
 2. In order to prevent the motor/gearbox from overheating the hoist should not be operated for longer than four minutes at any one time. Any period of use should be followed by a similar period with the hoist at rest.
 3. Do not wind loose cable onto drum - ensure that cable is always under tension.

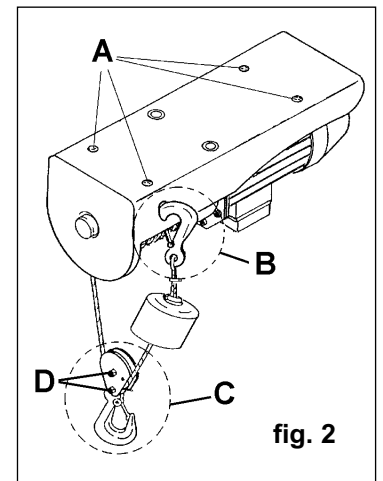

fig. 2

5. MAINTENANCE

The hoist should be checked at regular intervals to ensure that it is undamaged and is functioning correctly.

- 5.1. Isolate from the power supply and inspect the following for any signs of damage, wear or looseness, as appropriate:

a) Lifting cable	d) Mounting brackets/bolts
b) Electrical cables/connections	e) Support structure
c) Control switch	

 Rectify any faults found.
- 5.2. Reconnect to power supply and check for correct operation of the control switch and the maximum lift cut-out switch - hoist stops when counterweight (fig.1.5) lifts cut-out arm (fig.1.6).

