

Thank you for purchasing a Sealey product. Manufactured to a high standard this product will, if used according to these instructions and properly maintained, give you years of trouble free performance.

IMPORTANT: PLEASE READ THESE INSTRUCTIONS CAREFULLY. NOTE THE SAFE OPERATIONAL REQUIREMENTS, WARNINGS AND CAUTIONS. USE THE PRODUCT CORRECTLY AND WITH CARE FOR THE PURPOSE FOR WHICH IT IS INTENDED. FAILURE TO DO SO MAY CAUSE DAMAGE AND/OR PERSONAL INJURY AND WILL INVALIDATE THE WARRANTY. PLEASE KEEP INSTRUCTIONS SAFE FOR FUTURE USE.

1. CONTENTS

	Page No.
Section 2. General	1.
Section 2.1 Identification	1.
Section 2.2. Technical Data	1.
Section 3. Safety/Operational Instructions.	2.
Section 4. Maintenance/Examination/Inspection.	2.
Section 5. Assembly and storage.	3.
Section 6. Owner's & Operator's Responsibilities.	3.
Section 7. Declaration of Conformity.	4.
Section 8. Parts List/Diagram	5.

2. GENERAL

2.1 Identification

Supplier: Sealey Power Products,
 Kempson Way,
 Suffolk Business Park,
 Bury St Edmunds,
 Suffolk, IP32 7AR.

Model No: PH20.V3

2.2 Technical Data

Rated Capacity

Safe Working Load (SWL) 10t (tested to 50% overload).
 Working Load Limit (WLL) 10t (tested to 50% overload).

Max. lift @ min. jib extension:	1880mm
Max. lift @ max. jib extension:	2320mm
Max. height of frame legs:	190mm
Max. length of frame:	1740mm
Max. width of frame legs:	1040mm
Overall height:	1560mm
Width (max) inside frame legs:	890mm
Distance between rear wheel centres:	750mm
Weight:83kg

- a) Design Capability: Test Load 50% overload.
- b) For a description of in-service and out-of-service conditions see section 3 Safety, Section 4 Maintenance and Section 6.
- c) The crane is fitted with a bypass valve that will prevent the ram from over extending.
- d) For applications see Section 3 Safety.
- e) For control system, see Fig.1 for release valve and pump handle assy. Usage is explained in Section 3.2 Operation.
- f) For ground condition requirements, see Section 3 Safety.
- g) For information on parts and materials requiring specialised repair techniques see Section 4 Maintenance.

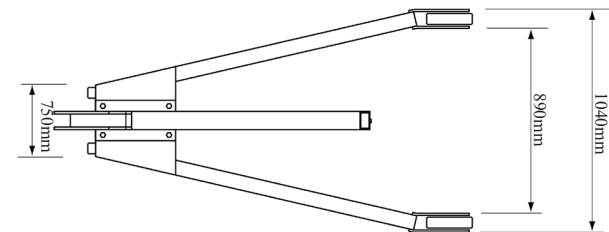
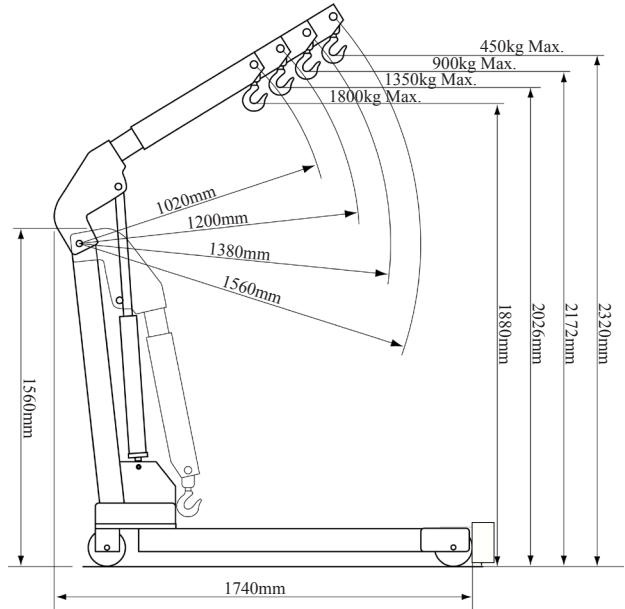

Lifting capacity:
 Position 1: 1800kg
 Position 2: 1350kg
 Position 3: 900kg
 Position 4: 450kg

Length of jib:
 Position 1: 1020mm
 Position 2: 1200mm
 Position 3: 1380mm
 Position 4: 1560mm

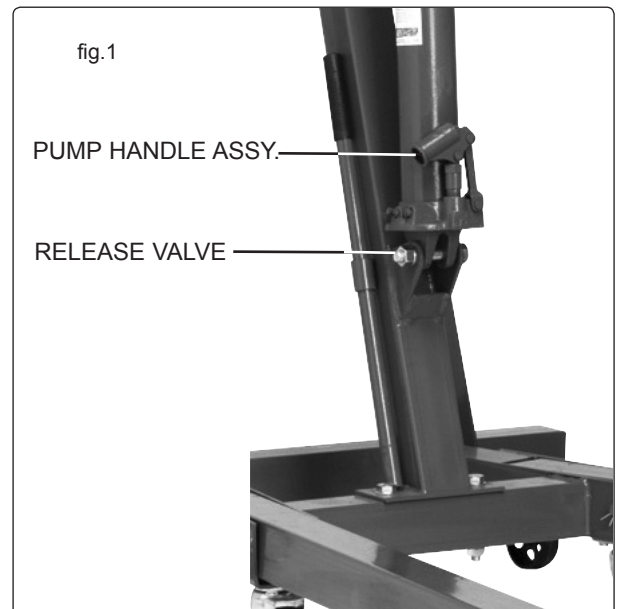

3. SAFETY/OPERATING INSTRUCTIONS

3.1 SAFETY

- ✓ **Keep** crane, lifting slings, support and beams in good working order and condition. Follow the inspection requirements as described in Section 4 page 2 Maintenance. *Take immediate action to repair or replace damaged parts by contacting your supplier. Ensure that all accessory lifting devices are suitably certified. If crane is damaged, remove from service immediately.*
- ✓ **Ensure the surface on which the crane is used is level, firm and capable of supporting the weight of the crane with maximum load - we recommend concrete. Never use the crane on tarmacadam or other soft surfaces.**
- ✓ **Ensure** the crane legs and arms are locked before use.
- ✓ **Keep** children and unauthorised persons away from the working area.
- ✓ **Keep** working area clean and tidy, free from unrelated materials and ensure that there is adequate lighting.
- ✓ **Ensure** that load does not exceed the maximum lifting capacity of the crane. Overloading the crane is dangerous. Where appropriate, use only the lifting points recommended by the manufacturer of the item to be lifted, e.g. vehicle engine.
- ✓ **Before** lifting the load ensure that the crane jib is in the lowest practical position, that there are no obstacles which may snag the load whilst it is being lifted and that the area above the jib is clear.
- ✓ **To avoid injury**, be fully aware of your own and other persons locations in relation to the lifting, and lowering, of the load.
- ✓ **Keep** a sound footing and balance, and ensure the floor is not slippery.
- ✓ **Ensure** jib extension locking bolt and nut are in position before lifting.
- ✓ **Ensure** the centre of gravity always remains inside the crane base.
- ✗ **DO NOT** harness the load at an angle or use any attachments not verified as fit for purpose.
- ✗ **DO NOT** allow the load to swing during lifting.
- ✗ **DO NOT** allow the load to drop suddenly. Lower load with care, ensuring that you are fully aware of the condition of the surface onto which the load is to be placed.
- ✗ **DO NOT** load crane beyond its rated capacity for each specified jib extension position as indicated in Section 2 page 1. The capacity of the crane reduces as the jib is extended.
- ✗ **DO NOT** position any part of your body beneath the load.
- ✗ **DO NOT** use the crane to move or transport a load other than for repositioning (see 3.2.f). The crane is a lifting device only.
- ✗ **DO NOT** apply any sideways pressure to any part of the crane during lifting or when a load is suspended.
- ✗ **DO NOT** attempt to adjust the safety valve, which has been set and sealed by the manufacturer.
- ✗ **DO NOT** use this product to perform a task for which it is not designed.
- ✗ **DO NOT** use whilst under the influence of drugs, alcohol or intoxicating medication.
- ✗ **DO NOT** climb on the crane.
- ✓ **When not in use** fold the crane down and store in a safe, dry, childproof area.
- ✓ **This crane is designed for lifting within a garage or workshop environment.**
- WARNING! Failure to heed safety and warning instructions may result in damage and/or personal injury and will invalidate the warranty.**



NOTE: ENSURE YOU HAVE READ AND UNDERSTOOD THE SAFETY INSTRUCTIONS AT THE BEGINNING OF THIS SECTION BEFORE YOU OPERATE THE CRANE.

3.2 OPERATION. (Refer to Section 4.2 regarding inspection before each and every use).

- a) Use the pump handle recess to tighten the release valve, turning firmly clockwise.
- b) Place handle into pump socket and pump, the jib will raise. Continue to pump until the jib reaches the height at which the load can be secured.
- c) Connect the crane hook to the load using a suitable **certified** sling or support beam. Ensure you are aware of the load weight, and check that it is within the capacity of the crane (at the jib extension you are using) and the sling or support beam. When removing engines ensure you know the weight to be lifted. Use only the lifting points recommended by the vehicle manufacturer.
- d) Lift only from directly above the load. **WARNING! DO NOT LIFT THE LOAD AT AN ANGLE!**
- e) To lower load, position handle on release valve at base of ram and turn **VERY SLOWLY anti-clockwise** avoiding any sudden movement. **WARNING!** Do not allow the load to drop suddenly.
- f) The crane is not a transportation device but may be used to reposition the load being worked on. To do so, lower load and jib with care, to the lowest possible point before attempting to move. Do not try to move crane in a sideways direction. The crane is not designed to support the load indefinitely. When you have repositioned the load, lower the load onto a secure and appropriate working base, being fully aware of your own and other persons locations in relation to the lowering load.
- g) When load has been secured, remove lifting sling, support beam etc. and place crane in a safe location with lifting beam fully lowered.

4. MAINTENANCE/EXAMINATION/INSPECTION

NOTE: The crane MUST be kept clean and dry and must be maintained in accordance with these instructions.

4.1. Lubrication.

- a) Oil all working parts monthly.
- b) The ram is filled with oil and should only require occasional topping up. For the occasional top up **DO NOT** use brake fluid, as this will damage the hydraulic seals. Proceed as follows:
 - a) Use only good quality hydraulic jack oil available from your supplier.
 - b) **DO NOT OVERFILL** as this will cause failure.
 - c) After filling with hydraulic oil, pump the crane up to full height and pour off any excess oil.

4.2. Inspection and Examination of Crane Before Use.

- a) Before each use of the crane you must perform an inspection for leaks, damage, loose or missing parts.
- b) The workshop crane must be examined immediately if it has been subject to an abnormal load or shock. It is recommended that such an examination is made by an authorised service agent.
- c) The owner and/or operator must be aware that repair of this equipment will require specialised knowledge and facilities. It is recommended that an annual examination of the workshop crane is made by an authorised service agent.
- d) Unauthorised parts may be dangerous and will invalidate the warranty.

Note! Please see the Definition of 'inspection' and 'examination' below.

Inspection:

Looking at the crane for defects and checking the operation of the controls, limiting and indicating devices without loading the crane. This is much more than a check but does not normally require any part of the crane to be dismantled other than removal or opening of covers or housings.

Examination:

Verification that the crane can safely continue in service including a functional test of all safety devices i.e. limiting, indicating equipment, brakes, clutches, safety valves etc to verify that they operate within the required tolerances. An examination is more thorough than an inspection.

5. ASSEMBLY/STORAGE INSTRUCTIONS

5.1 ASSEMBLY.

Note: Numbers in brackets refer to item numbers as shown in the parts diagram (Section 8, page 4).

- a. Assembly procedure is as follows. (Numbers in brackets refer to the parts diagram - please refer to this for appropriate positioning).
- b. Attach wheels (22) to the appropriate points on the base (29) using bolts, washers, lock washers and nuts (2,3,4,5).
- c. Attach wheels (23-small wheels) to appropriate points on base (29) using bolts, washers and lock washers (1,3,4).
- d. Attach wheels (22) to appropriate points on the legs (30) using bolts, washers, lock washers and nuts (2,3,4,5).
- e. Slot the legs (30) into the base (29) and secure with pins (6), and use hair pins to secure these.
- f. Attach the post (26) to the front of the base (29) using bolts, washers, lock washers and nuts (10,7,8,9).
- g. Attach supports (27) to the base (29) using bolts, washers, lock washers and nuts (10,7,8,9).
- h. Attach the tops of the supports (27) to the post (26) using bolt, washer, lock washer and nut (10,7,8,9).
- i. Attach the base of the ram unit (28) to the lower fixing point of the post (26) using bolt, washer, lock washer and nut (11,12,13,14).
- j. Attach the boom (25) to the top of the post (26) using bolt, washer, lock washer and nut (15,18,19,20).
- k. Attach the piston head of the ram unit (28) to appropriate point on the boom (25) using bolt, washer, lock washer and nut (17,12,13,14).
- l. Slot the boom extension (24) into the boom (25) and secure using pin (16) and use a hair pin to secure this. Be sure to select the correct extension for the weight to be lifted.
- m. Attach the hook and chain (31) to the boom using bolt, washer, lock washer and nut (21,7,8,9).
- n. Open the release valve of the ram by turning anticlockwise using the groove in the pump handle (32) provided. Pump the ram 10-20 times. This is necessary to flush the hydraulic system and purge any air that may be present.
- o. Pull the jib up slightly, close the release valve (turn clockwise) and pump the handle. The jib should now raise. Pump the jib all the way up and then lower it slowly by opening the release valve. This is to confirm that the oil level is correct. Close the release valve. The crane is now ready for use. Ensure it is not damaged in any way. Should you experience any problems, contact your supplier immediately.

5.2 STORAGE.

- a) Always store the crane fully closed so that the jib is in lowest position and the ram is closed.
- b) To save space the legs may be folded into the upright position and secured in place using the Lock Pins.

6. OWNER'S & OPERATOR'S RESPONSIBILITIES

The owner and/or operator shall study these instructions and retain them for future use.

- a) **Understanding instructions and warnings.**
The owner and/or operator shall understand the operating instructions and warnings before operating the crane.
Warning information must be emphasised and understood.
If the operator is not fluent in English, the product instructions and warnings must be read to, and discussed with, the operator in the operator's native language by the owner, making sure the operator understands the contents.
- b) **Damaged Cranes.**
Any crane which appears to be damaged, badly worn, or operates abnormally **MUST BE REMOVED FROM SERVICE!** It is recommended that necessary repairs be made by an authorised service agent.
- c) **End of service.**
Through years of normal wear, the crane will eventually become unserviceable. When this happens ensure the hydraulic oil is drained off and disposed of in accordance with local authority regulations.



NOTE: It is our policy to continually improve products and as such we reserve the right to alter data, specifications and component parts without prior notice.

IMPORTANT: No liability is accepted for incorrect use of this product.

WARRANTY: Guarantee is 12 months from purchase date, proof of which will be required for any claim.

INFORMATION: For a copy of our latest catalogue and promotions call us on 01284 757525 and leave your full name and address, including postcode.



Sole UK Distributor, Sealey Group,
Kempson Way, Suffolk Business Park,
Bury St. Edmunds, Suffolk,
IP32 7AR

01284 757500

01284 703534



www.sealey.co.uk



sales@sealey.co.uk



EC DECLARATION OF CONFORMITY

We the sole importers into the UK, hereby declare that the equipment described below

Description and Function:..... Folding Workshop Crane - 1.8 tonnes.....

Model/Type:..... PH20.....

Serial number (optional):.....

Manufacturer's authorised representative within the EC: **Jack Sealey Ltd. Kempson Way, Suffolk Business Park, Bury St. Edmunds, Suffolk, IP32 7AR**

Conforms to the requirements of the following Directives, as indicated.

- 2006/42/EC Machinery Directive
- 2000/14/EC Outdoor Noise Emissions Directive
- 2006/95/EC Low Voltage Directive
- 2002/96/EC WEEE Directive
- 2004/108/EC EMC Directive
- 2002/95/EC RoHS Directive
- 93/68/EEC CE Marking Directive

And the following harmonised standard(s): **BS EN 14238: 2004** **BS EN 12644 part 1: 2001**.....

BS EN 12644 part 2: 2000 **BS EN 1494: 2001**.....

National technical standards and specifications (if applicable):.....

Technical file compiled by: **Jack Sealey Ltd.**

Signed: 

Date:..... 02-Nov-2009.....

Place: Bury St.Edmunds.

Name:..... Mark Sweetman.....

Position: Managing Director.....

Being the responsible person appointed by the manufacturer.



Sealey Power Products, Kempson Way,
Suffolk Business Park, Bury St. Edmunds,
Suffolk, IP32 7AR

 01284 757500

 01284 703534

 sales@sealey.co.uk

 www.sealey.co.uk

8. PARTS LIST/DIAGRAM

MODEL: PH20.V3

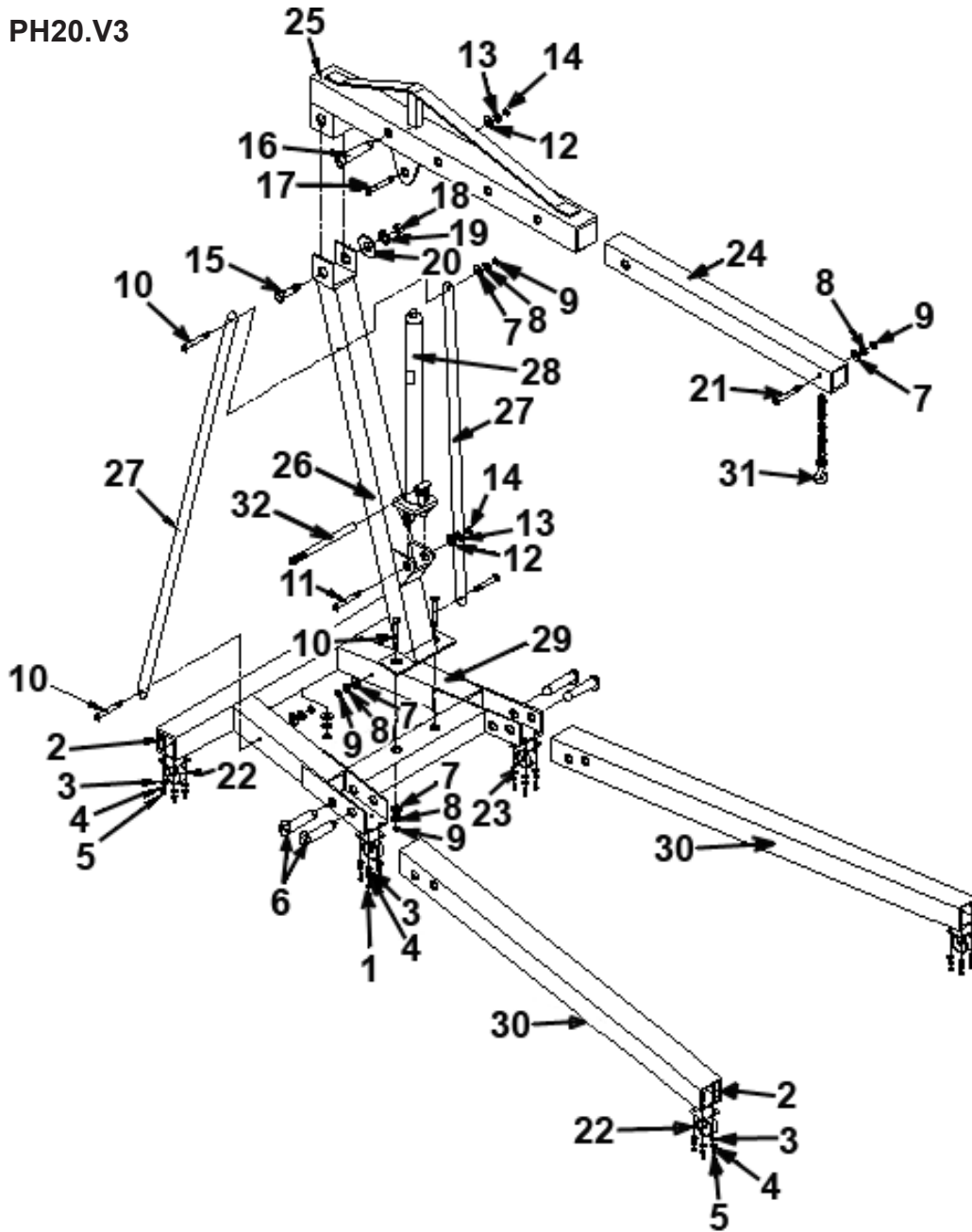

Item	Part No.	Description	Item	Part No.	Description
1	PH20.V3-00	BOLT M8X14	17	PH20.V3-16	BOLT M16X80
2	PH20.V3-01	BOLT M8X20	18	PH20.V3-17	NUT M18
3	PH20.V3-02	WASHER M8	19	PH20.V3-18	LOCK WASHER
4	PH20.V3-03	LOCK WASHER M8	20	PH20.V3-19	WASHER M18
5	PH20.V3-04	NUT M8	21	PH20.V3-20	BOLT M14X80
6	PH20.V3-05	PIN	22	PH20.V3-21	CASTER WHEEL, LARGE
7	PH20.V3-06	WASHER M14	23	PH20.V3-22	CASTER WHEEL, SMALL
8	PH20.V3-07	LOCK WASHER M14	24	PH20.V3-A	BOOM EXTENSION
9	PH20.V3-08	NUT M14	25	PH20.V3-B	BOOM
10	PH20.V3-09	BOLT M14X100	26	PH20.V3-C	POST
11	PH20.V3-10	BOLT M16X90	27	PH20.V3-D	SUPPORT BRACE
12	PH20.V3-11	WASHER M16	28	PH20.V3-E	HYDRAULIC UNIT
13	PH20.V3-12	LOCK WASHER M16	29	PH20.V3-F	"A" FRAME BASE
14	PH20.V3-13	NUT M16	30	PH20.V3-G	LEG
15	PH20.V3-14	BOLT M18X110	31	PH20.V3-H	CHAIN C/W HOOK
16	PH20.V3-15	PIN	32	PH20.V3-I	PUMPING HANDLE

NOTE: It is our policy to continually improve products and as such we reserve the right to alter data, specifications and component parts without prior notice.

IMPORTANT: No liability is accepted for incorrect use of this product.

WARRANTY: Guarantee is 12 months from purchase date, proof of which will be required for any claim.

INFORMATION: For a copy of our latest catalogue and promotions call us on 01284 757525 and leave your full name and address, including postcode.



Sole UK Distributor, Sealey Group,
Kempson Way, Suffolk Business Park,
Bury St. Edmunds, Suffolk,
IP32 7AR



01284 757500

01284 703534



www.sealey.co.uk

sales@sealey.co.uk