

Thank you for purchasing a Sealey product. Manufactured to a high standard this product will, if used according to these instructions and properly maintained, give you years of trouble free performance.

IMPORTANT: PLEASE READ THESE INSTRUCTIONS CAREFULLY. NOTE THE SAFE OPERATIONAL REQUIREMENTS, WARNINGS AND CAUTIONS. USE THE PRODUCT CORRECTLY AND WITH CARE FOR THE PURPOSE FOR WHICH IT IS INTENDED. FAILURE TO DO SO MAY CAUSE DAMAGE AND/OR PERSONAL INJURY AND WILL INVALIDATE THE WARRANTY. PLEASE KEEP INSTRUCTIONS SAFE FOR FUTURE USE.

1. CONTENTS

	Page No.
Section 2. General	1.
Section 2.1. Identification	1.
Section 2.2. Technical Data	1.
Section 3. Safety / Operational Instructions	2.
Section 4. Maintenance / Examination / Inspection	2.
Section 5. Assembly and storage	3.
Section 6. Owner's & Operator's Responsibilities	3.
Section 7. Declaration of Conformity	4.
Section 8. Parts List / Diagram	5.

2. GENERAL

2.1 Identification
 Supplier: Sealey Power Products,
 Kempson Way,
 Suffolk Business Park,
 Bury St Edmunds,
 Suffolk, IP32 7AR.

Model No: PH10.V3

2.2 Technical Data

Rated Capacity

- Safe Working Load (SWL) 1tonne (tested to 50% overload).
- Working Load Limit (WLL) 1tonne (tested to 50% overload).
- Lifting Cap. in Position 1: 1000kg
- Lifting Cap. in Position 2: 800kg
- Lifting Cap. in Position 3: 700kg
- Maximum Lift Ht. at Minimum Jib Extn: 2180mm
- Maximum Lift Ht. at Maximum Jib Extn: 2270mm
- Length of Jib Position 1: 1035mm
- Length of Jib Position 2: 1160mm
- Length of Jib Position 3: 1280mm

- a) Design Capability: Test Load 50% overload.
- b) For a description of in-service and out-of-service conditions see section 3 Safety, Section 4 Maintenance and Section 6.
- c) The crane is fitted with a bypass valve that will prevent the ram from over extending.
- d) For applications see Section 3 Safety.
- e) For control system, see Fig.1 for release valve and pump handle assy. Usage is explained in Section 3.2 Operation.
- f) For ground condition requirements, see Section 3 Safety.
- g) For information on parts and materials requiring specialised repair techniques see Section 4 Maintenance.

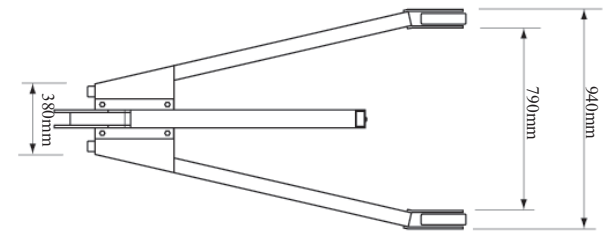
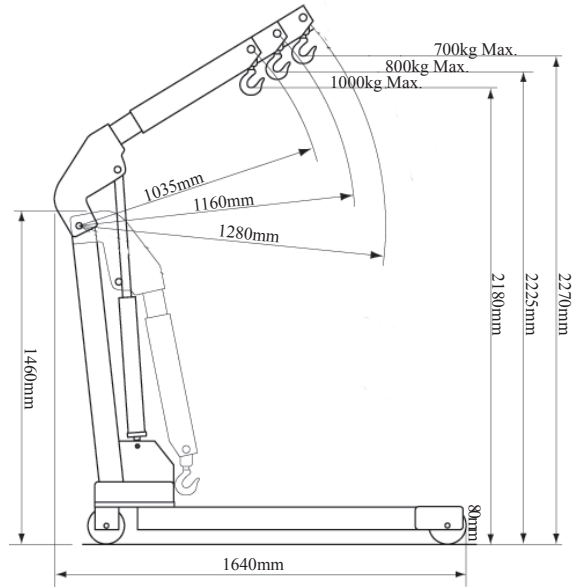

- Height of Frame: 80mm
- Length of Frame: 1640mm
- Overall Height: 1460mm
- Maximum Width of Frame: 940mm
- Width Inside Frame: 790mm
- Distance between Centres of Rear Wheels: 380mm
- Weight: 71kg

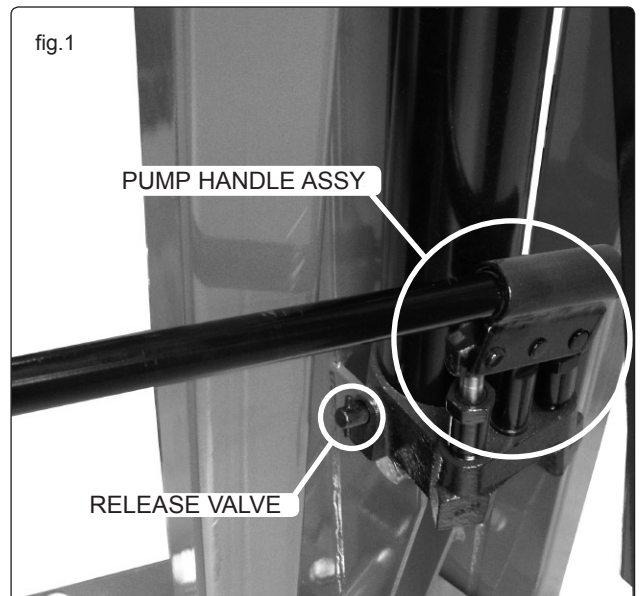

3. SAFETY / OPERATING INSTRUCTIONS

3.1 SAFETY

- ✓ **Keep** crane, lifting slings, support and beams in good working order and condition. Follow the inspection requirements as described in Section 4 page 2 Maintenance. *Take immediate action to repair or replace damaged parts by contacting your supplier. Ensure that all accessory lifting devices are suitably certified. If crane is damaged, remove from service immediately.*
- ✓ **Ensure the surface on which the crane is used is level, firm and capable of supporting the weight of the crane with maximum load - we recommend concrete. Never use the crane on tarmacadam or other soft surfaces.**
- ✓ **Ensure** the crane legs and arms are locked before use.
- ✓ **Keep** children and unauthorised persons away from the working area.
- ✓ **Keep** working area clean and tidy, free from unrelated materials and ensure that there is adequate lighting.
- ✓ **Ensure** that load does not exceed the maximum lifting capacity of the crane. Overloading the crane is dangerous. Where appropriate, use only the lifting points recommended by the manufacturer of the item to be lifted, e.g. vehicle engine.
- ✓ **Before** lifting the load ensure that the crane jib is in the lowest practical position, that there are no obstacles which may snag the load whilst it is being lifted and that the area above the jib is clear.
- ✓ **To** avoid injury, be fully aware of your own and other persons locations in relation to the lifting, and lowering, of the load.
- ✓ **Keep** a sound footing and balance, and ensure the floor is not slippery.
- ✓ **Ensure** jib extension locking bolt and nut are in position before lifting.
- ✓ **Ensure** the centre of gravity always remains inside the crane base.
- ✗ **DO NOT** harness the load at an angle or use any attachments not verified as fit for purpose.
- ✗ **DO NOT** allow the load to swing during lifting.
- ✗ **DO NOT** allow the load to drop suddenly. Lower load with care, ensuring that you are fully aware of the condition of the surface onto which the load is to be placed.
- ✗ **DO NOT** load crane beyond its rated capacity for each specified jib extension position as indicated in Section 2 page 1. The capacity of the crane reduces as the jib is extended.
- ✗ **DO NOT** position any part of your body beneath the load.
- ✗ **DO NOT** use the crane to move or transport a load other than for repositioning (see 3.2.f). The crane is a lifting device only.
- ✗ **DO NOT** apply any sideways pressure to any part of the crane during lifting or when a load is suspended.
- ✗ **DO NOT** attempt to adjust the safety valve, which has been set and sealed by the manufacturer.
- ✗ **DO NOT** use this product to perform a task for which it is not designed.
- ✗ **DO NOT** use whilst under the influence of drugs, alcohol or intoxicating medication.
- ✗ **DO NOT** climb on the crane.
- ✓ **When** not in use fold the crane down and store in a safe, dry, childproof area.
- ✓ **This crane is designed for lifting within a garage or workshop environment.**
- ☐ **WARNING!** Failure to heed safety and warning instructions may result in damage and/or personal injury and will invalidate the warranty.



NOTE: ENSURE YOU HAVE READ AND UNDERSTOOD THE SAFETY INSTRUCTIONS AT THE BEGINNING OF THIS SECTION BEFORE YOU OPERATE THE CRANE.

3.2 OPERATION. (Refer to Section 4.2 (a) regarding inspection before each and every use).

- a) Use the pump handle recess to tighten the release valve, turning firmly clockwise.
- b) Place handle into pump socket and pump, the jib will raise. Continue to pump until the jib reaches the height at which the load can be secured.
- c) Connect the crane hook to the load using a suitable **certified** sling or support beam. Ensure you are aware of the load weight, and check that it is within the capacity of the crane (at the jib extension you are using) and the sling or support beam. When removing engines ensure you know the weight to be lifted. Use only the lifting points recommended by the vehicle manufacturer.
- d) Lift only from directly above the load. **WARNING! DO NOT LIFT THE LOAD AT AN ANGLE!**
- e) To lower load, position handle on release valve at base of ram and turn **VERY SLOWLY anti-clockwise** avoiding any sudden movement. **WARNING!** Do not allow the load to drop suddenly.
- f) The crane is not a transportation device but may be used to reposition the load being worked on. To do so, lower load and jib with care, to the lowest possible point before attempting to move. Do not try to move crane in a sideways direction. The crane is not designed to support the load indefinitely. When you have repositioned the load, lower the load onto a secure and appropriate working base, being fully aware of your own and other persons locations in relation to the lowering load.
- g) When load has been secured, remove lifting sling, support beam etc. and place crane in a safe location with lifting beam fully lowered.

4. MAINTENANCE / EXAMINATION / INSPECTION

NOTE: The crane MUST be kept clean and dry and must be maintained in accordance with these instructions.

4.1. Lubrication.

- a) Oil all working parts monthly.
- b) The ram is filled with oil and should only require occasional topping up. For the occasional top up **DO NOT** use brake fluid, as this will damage the hydraulic seals. Proceed as follows:
 - a) Use only good quality hydraulic jack oil available from your supplier.
 - b) **DO NOT OVERFILL** as this will cause failure, with ram in lowered position remove rubber bung located on the ram and top up to just below the filling hole. Replace rubber bung.
 - c) After filling with hydraulic oil, pump the crane up to full height and pour off any excess oil.

4.2. Inspection and Examination of Crane Before Use.

- a) Before each use of the crane you must perform an inspection for leaks, damage, loose or missing parts.
- b) The workshop crane must be examined immediately if it has been subject to an abnormal load or shock. It is recommended that such an examination is made by an authorised service agent.
- c) The owner and/or operator must be aware that repair of this equipment will require specialised knowledge and facilities. It is recommended that an annual examination of the workshop crane is made by an authorised service agent.
- d) Unauthorised parts may be dangerous and will invalidate the warranty.

Note! Please see the Definition of 'inspection' and 'examination' below.

Inspection:

Looking at the crane for defects and checking the operation of the controls, limiting and indicating devices without loading the crane. This is much more than a check but does not normally require any part of the crane to be dismantled other than removal or opening of covers or housings.

Examination:

Verification that the crane can safely continue in service including a functional test of all safety devices i.e. limiting, indicating equipment, brakes, clutches, safety valves etc to verify that they operate within the required tolerances. An examination is more thorough than an inspection.

5. ASSEMBLY / STORAGE INSTRUCTIONS

5.1 ASSEMBLY.

Unpack the product and check contents against the parts list in these instructions. Should there be any damaged or missing parts contact your supplier immediately. We recommend two people assemble the crane as follows:

- Fig. A. Attach two rear swivel castors (10) to base (9) using bolts (20), lock washers (19), flat washers (18), inner spacers (17), wheel bracket (16), flat washers (15).
- Fig. B. Attach two legs (11) to the base (9) using pins (12), flat washers (2) and lock nuts (3), then screw the legs onto base with nuts (13) and flat washers (14).
- Fig. C. Attach main support assembly (23) onto the base (9) using two short bolts M12x25 (42), lock nuts (3), flat washers (2) and four long bolts M12x110 (21), lock nuts (3), flat washers (2).
- Fig. D - E. Secure the boom (28) to the main support post (23) using bolt (25) and lock nut (26). While assistant holds the boom up, connect the top of the ram unit (37) to boom (28) using bolt (35), nut (27).

Bleed the Hydraulic System: Place the pump handle into the pump socket, open the release valve and pump handle 10-15 times through the full stroke, thus bleeding from the hydraulic system, any air which may have entered during transit.

5.2 STORAGE.

- Always store the crane fully closed so that the jib is in lowest position and the ram is closed.
- To save space the legs may be folded into the upright position and secured in place using the Lock Pins.

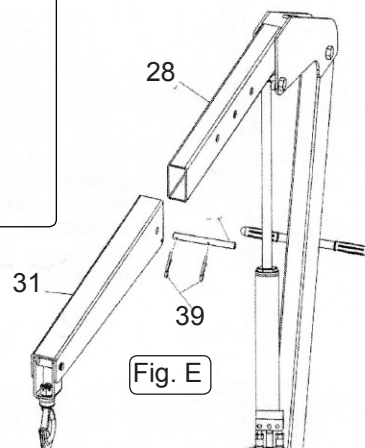
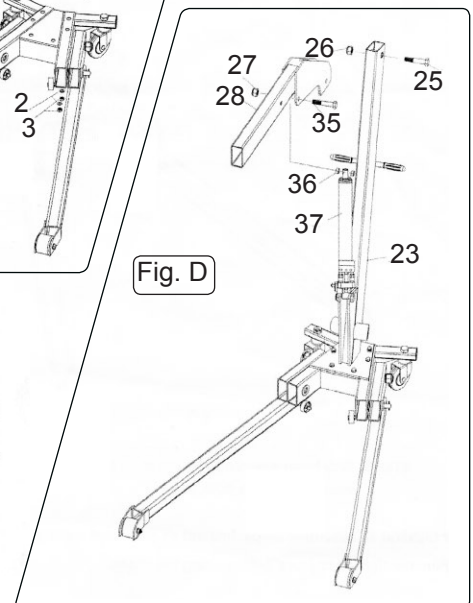
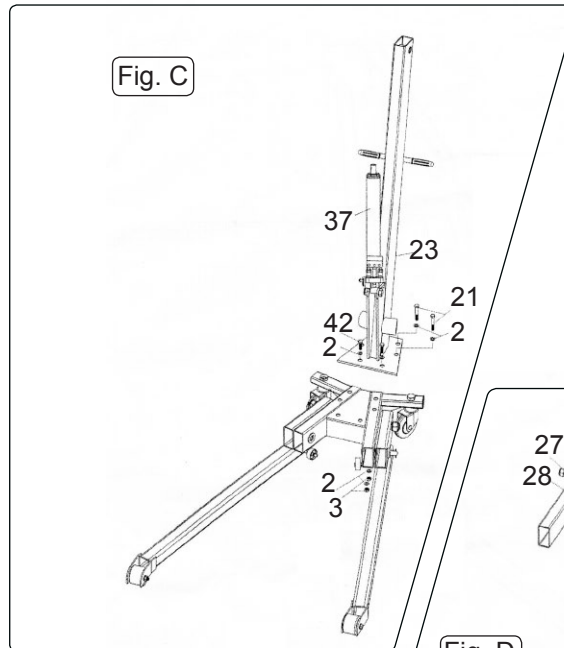
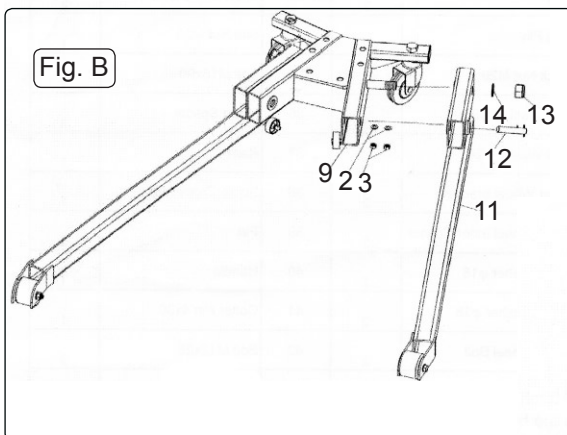
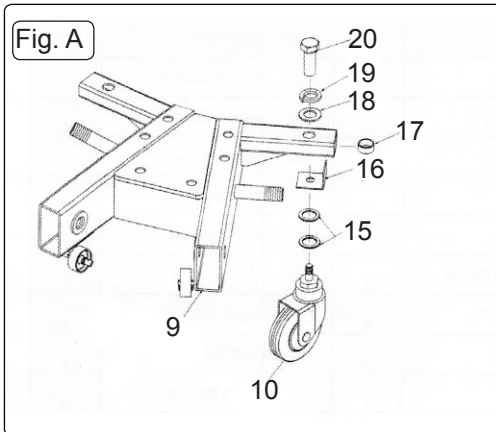

6. OWNER'S & OPERATOR'S RESPONSIBILITIES

The owner and/or operator shall study these instructions and retain them for future use.

- Understanding instructions and warnings.**
The owner and/or operator shall understand the operating instructions and warnings before operating the crane. Warning information must be emphasised and understood.
If the operator is not fluent in English, the product instructions and warnings must be read to, and discussed with, the operator in the operator's native language by the owner, making sure the operator understands the contents.
- Damaged Cranes.**
Any crane which appears to be damaged, badly worn, or operates abnormally **MUST BE REMOVED FROM SERVICE!** It is recommended that necessary repairs be made by an authorised service agent.
- End of service.**
Through years of normal wear, the crane will eventually become unserviceable. When this happens ensure the hydraulic oil is drained off and disposed of in accordance with local authority regulations.



EC DECLARATION OF CONFORMITY

We the sole importers into the UK, hereby declare that the equipment described below

Description and Function:..... Folding Engine Crane Yankee 1 tonne.....

Model/Type:..... PH10.V3.....

Manufacturing Date / Serial number (optional).....

Manufacturer's authorised representative within the EC: **Jack Sealey Ltd. Kempson Way, Suffolk Business Park, Bury St. Edmunds, Suffolk, IP32 7AR**

Conforms to the requirements of the following Directives, as indicated.

- 2006/42/EC Machinery Directive
- 2000/14/EC Outdoor Noise Emissions Directive
- 2006/95/EC Low Voltage Directive
- 2002/96/EC WEEE Directive
- 2004/108/EC EMC Directive
- 2002/95/EC RoHS Directive
- 93/68/EEC CE Marking Directive
- 97/23/EC Pressure Equipment Directive

And the following harmonised standard(s): **BS EN ISO 12100 part 1: 2003** **BS EN ISO 12100 part 2: 2003**.....

BS EN 1050: 1997 **BS EN 13001 part 1: 2004**.....

National technical standards and specifications (if applicable):.....

Technical file compiled by: **Jack Sealey Ltd.**

Signed:..... 

Date:..... 30-Apr-2010.....

Place: Bury St. Edmunds.

Name:..... Mark Sweetman.....

Position:..... Managing Director.....

Being the responsible person appointed by the manufacturer.



Sealey Power Products, Kempson Way, Suffolk Business Park, Bury St. Edmunds, Suffolk, IP32 7AR

 01284 757500

 01284 703534

 sales@sealey.co.uk

 www.sealey.co.uk

8. PARTS LIST/DIAGRAM

MODEL No: PH10.V3

Issue: 1
Issue Date: 210510

ITEM	PART NO	DESCRIPTION
1	PH10.V3-01	BOLT (M12x90)
2	PH10.V3-02	WASHER (M12)
3	PH10.V3-03	LOCK NUT (M12)
4	PH10.V3-04	BEARING
5	PH10.V3-05	FRONT WHEEL
6	PH10.V3-06	FRONT WHEEL SPACER
7	PH10.V3-07	SPLIT PIN (2.5x18)
8	PH10.V3-08	GUIDE WHEEL
9	PH10.V3-09	BASE
10	PH10.V3-10	REAR WHEEL
11	PH10.V3-11	LEG
12	PH10.V3-12	LEG PIN
13	PH10.V3-13	LOCK NUT (M20)
14	PH10.V3-14	WASHER (20mm)
15	PH10.V3-15	WASHER (24mm)
16	PH10.V3-16	REAR WHEEL BRACKET
17	PH10.V3-17	REAR WHEEL SPACER
18	PH10.V3-18	WASHER (18mm)
19	PH10.V3-19	LOCK WASHER (18mm)
20	PH10.V3-20	REAR WHEEL BOLT
21	PH10.V3-21	BOLT (M12x110)
22	PH10.V3-22	BOLT (M16x70)
23	PH10.V3-23	MAIN SUPPORT POST
24	PH10.V3-24	HANDLE GRIP
25	PH10.V3-25	BOLT (M18x90)
26	PH10.V3-26	LOCK NUT (M18)
27	PH10.V3-27	LOCK NUT (M16)
28	PH10.V3-28	BOOM
29	PH10.V3-29	SAFETY PIN
30	PH10.V3-30	CIRCLIP
31	PH10.V3-31	BOOM EXTENSION
32	PH10.V3-32	HOOK PIN
33	PH10.V3-33	CIRCLIP
34	PH10.V3-34	NUT (M20)
35	PH10.V3-35	BOLT (M16x90)
36	PH10.V3-36	SPACER
37	PH10.V3-37	RAM
38	PH10.V3-38	CROSS PIN
39	PH10.V3-39	PIN
40	PH10.V3-40	HANDLE
41	PH10.V3-41	COTTER PIN (4x30)
42	PH10.V3-42	BOLT (M12x25)
43	PH10.V3-43	BRACKET FOR HOOK
44	PH10.V3-44	HOOK

