

Owner's Manual

Model No.: PGC101

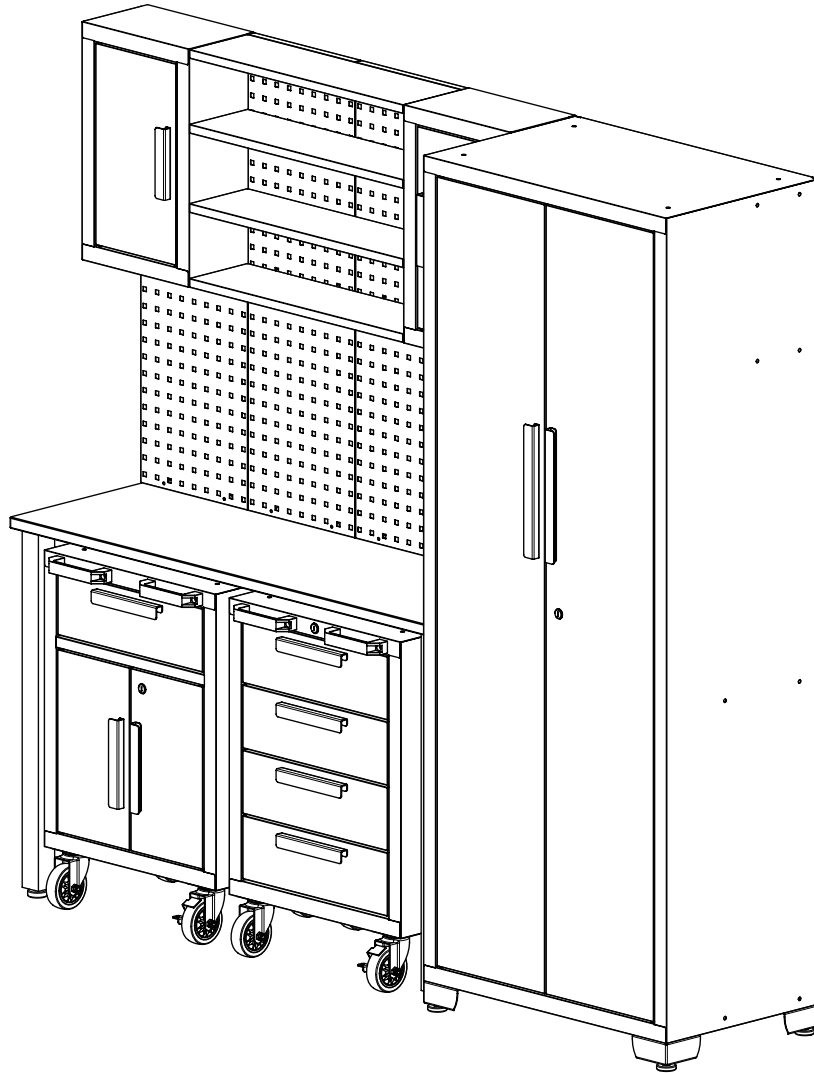

**Garage
Classic Series**

Important

When you open the cartons, carefully check the contents and make sure there is no damage. If you have any problems or you find any parts damaged or missing, Please contact with us first.

Do not return the product to the store before contacting us. Do not dispose of your cartons until you are completely satisfied with your products.

To reduce the risk of injury, the user should read and understand this owner's manual before assembling and using these products for the first time.

Fill in the following information and retain this manual for future reference:

Item No. _____
 Date of Purchase _____
 Place of Purchase _____
 Receipt No. _____

Safety Guidelines

● WARNING

Use two or more people to move, assemble, and install the product to avoid any injury.

● WARNING

DO NOT leave children unattended near the product.

● WARNING

DO NOT stand on the product or lean on the drawers or worktop.

● WARNING

WEAR SAFETY GLASSES when removing or repositioning the slides. The tools could slip, which may cause personal injury.

● WARNING

DO NOT alter the product in any manner. For example, do not weld external lock bars or attach unapproved electrical equipment. This may cause product damage, personal injury, or death.

● WARNING

DO NOT OVERLOAD PRODUCTS! The components of the product are designed to carry the following maximum weight capacities:

Cabinet	Shelf Weight Capacity (lbs.)	Drawer Weight Capacity (lbs.)	Bottom Weight Capacity (lbs.)	Top Weight Capacity (lbs.)	Overall Weight Capacity (lbs.)
Locker	150	/	220	150	820
Wall cabinet	/	/	50	/	50
1-drawer roller cabinet	100	70x1	100	100	370
4-drawer roller cabinet	/	70x4	/	100	380
52in workbench	/	/	/	800	800

● CAUTION

BE CAREFUL when opening more than one drawer. The product could become unstable and tip, which may cause product damage or personal injury.

● CAUTION

High risk of tipping if the product is not installed correctly. Securely attach the product to the wall to avoid serious injury.

Unpacking

1. Start by placing the package on flat covered ground.
2. Remove all cardboard, honey comb board, foam packaging material and clear plastic bags.
3. Recycle all packaging materials.
4. Verify all the contents are included and gather the tools required.

Hardware Included

No.	DESCRIPTION	WALL		1-DRAWER	4-DRAWER	52IN	PEGBOARD
		CABINET	LOCKER	R. CABINET	R. CABINET	WORKBENCH	
		x2	x1	x1	x1	x1	x 6
1	M6 Hex Flange Nut	8 x2	4	0	0	0	0
2	Flat Washer	4 x2	4	0	0	0	4 x6
3	Key	0	2	2	2	0	0
4	M5 x 50 Hex Tapping Bolt	4 x2	4	0	0	0	4 x6
5	M6 x 12 Flat-Head Bolt	8 x2	20	0	0	0	0
6	M5 x 12 Flat-Head Bolt (on the door)	2 x2	4	6	8	0	0
7	Adjustable Leveling Feet	0	4	0	0	0	0
8	Shelf	0	3	1	0	0	0
9	Casters	0	0	4	4	0	0
10	M8 x 20 Hex Flange Bolt	0	0	16	16	0	0
11	Grab Handle	0	0	2	2	0	0
12	M8 x 16 Flat-Head Bolt	0	0	4	4	8	0
13	M8 x 65 Hex Bolt	0	0	0	0	4	0
14	M8 Hex Flange Nut	0	0	0	0	4	0

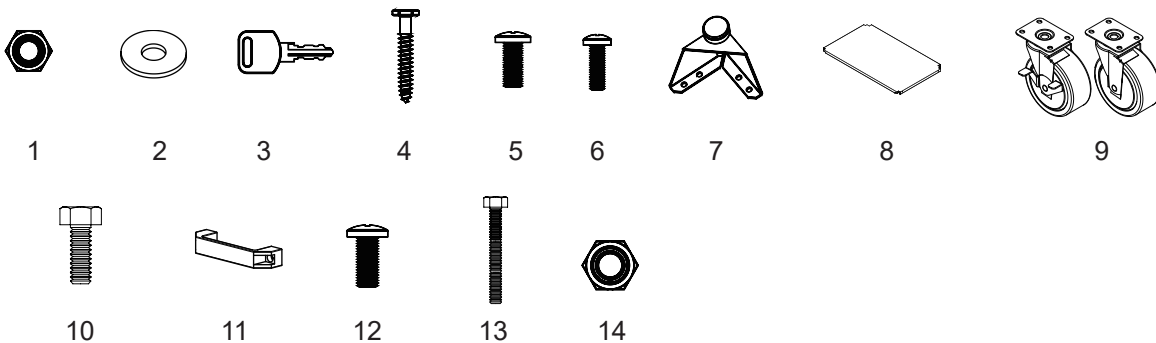

Tools Required

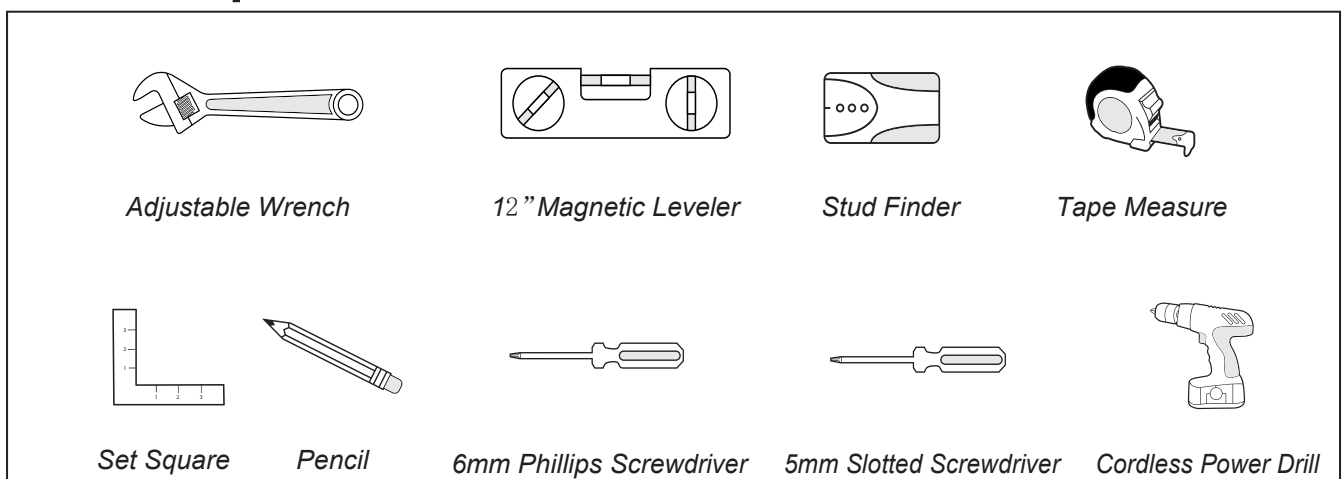

Locker x1

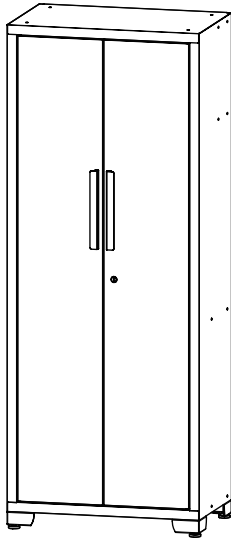

Wall cabinet x2

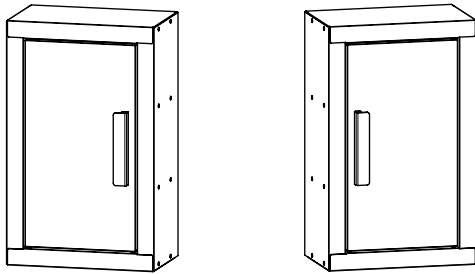

Shelf to connect the wall cabinets x4



1-drawer roller cabinet x1

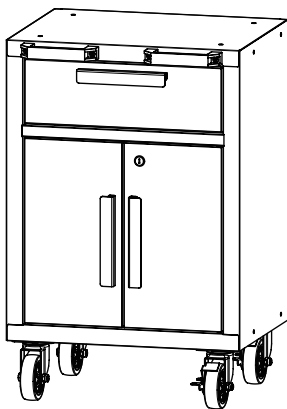

4-drawer roller cabinet x1

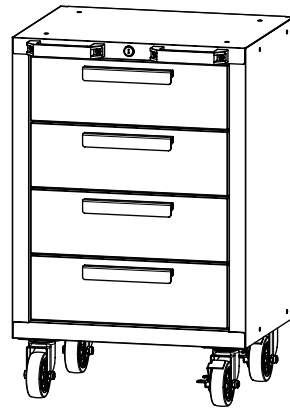

52in workbench x1

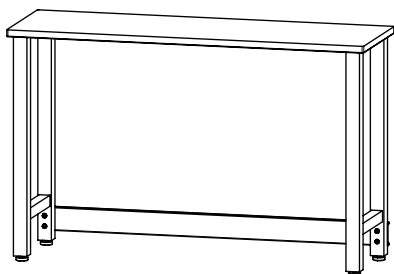

Pegboard x6

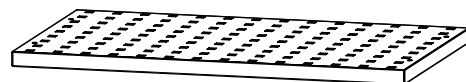

Installing the Handles

Unscrew the bolts on the front of the drawers or the doors using a Phillips screw driver to remove the handle on the back of it, then attach the handle to the front of the door or the drawer using two **M5x12** flat head bolts. Repeat for all the doors and drawers.

Attach the grab handle to the cabinet, align the holes and fix with two **M8x16** flat head bolts.

No. 6 x 2 each
M5 x 12mm Bolt

No. 11 x 2 each
Grab handle

No. 12 x 2 each
M8 x 16 Flat-head
bolt

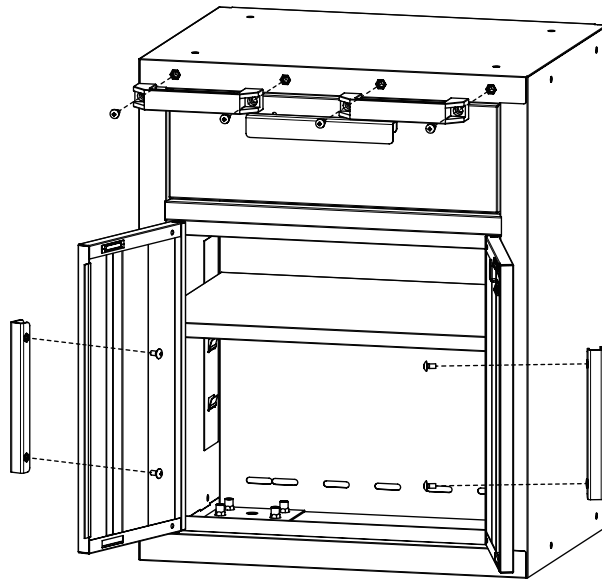

Installing the Casters

Lay the rolling cabinet on soft ground. Use the packaging material to protect the finish.

Mount four casters to each cabinet with sixteen **M8x20** hex flange bolts.

Note: The casters with brakes should be on the front side of the cabinet.

No. 9 x 4 each
Casters

No. 10 x 16 each
M8 x 20mm Hex
Flange Bolt

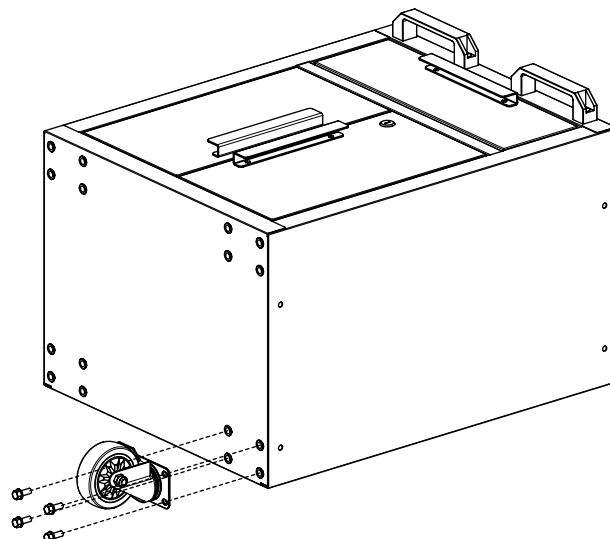

Installing the Feet

Carefully set the locker on its back, then attach the adjustable leveling feet to the locker using sixteen **M6x12** flat-head bolts with a Philips screw driver.

No. 5 x 16
M6 x 12mm
Flat-Head Bolt

No. 7 x 4
Adjustable Leveling
Feet

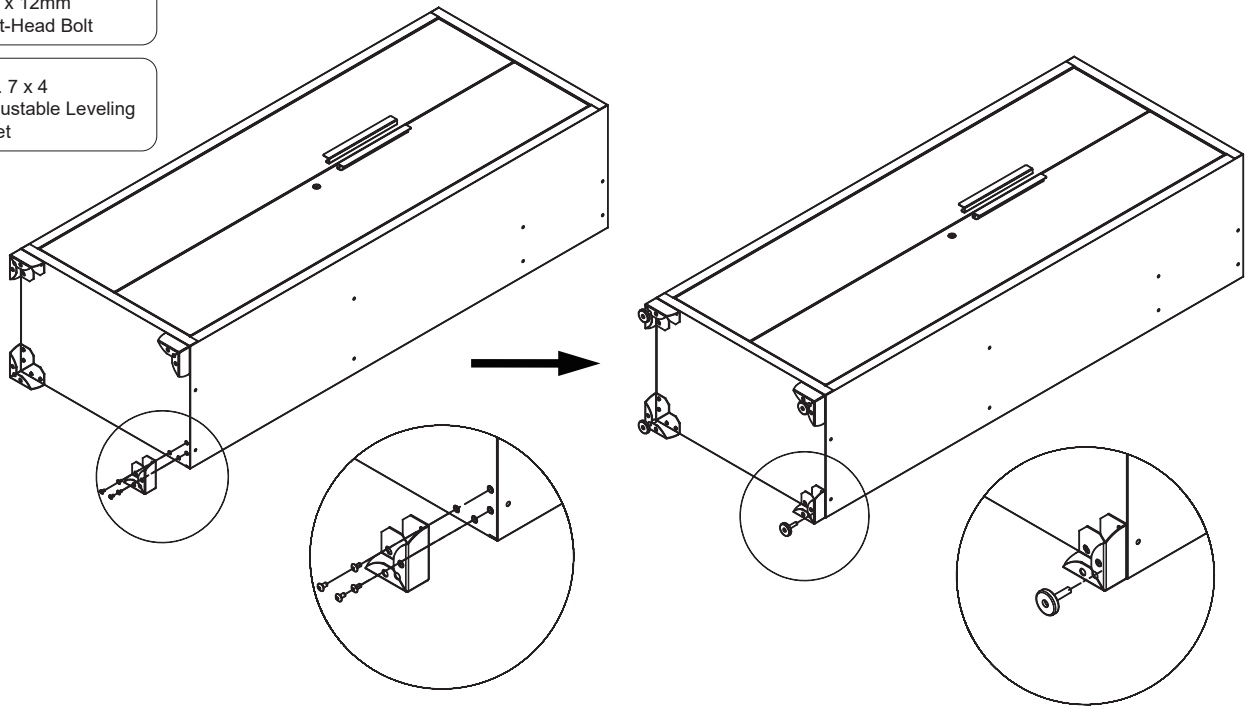

Installing the Shelves

Check the location need, carefully put the shelf into the slot .
Please make sure the shelf is stable.

NOTE: A center shelf must be installed level with the lock on the cabinet door in order for lock to work.

No. 8
Shelf

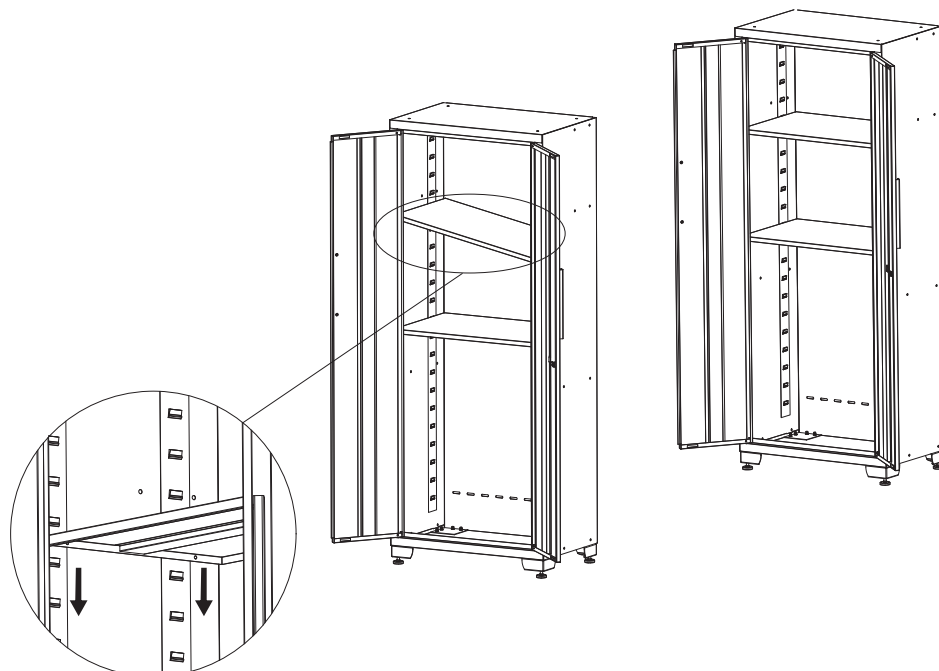
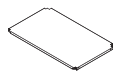

Installing the Workbench

1. Lay down the work top on a soft surface, align the holes on the legs with that on the worktop.
Use four **M8x16** bolts to connecting them together.
2. Use four **M8x65** hex bolts and four **M8** nuts to fasten support to the legs.
3. Fasten all the bolts and nuts.
4. Stand up the worbench to fihish this step.

No. 13 x 4
M8 x 65mm Hex bolt

No. 14 x 4
M8 Nut

No. 12 x 8
M8 x 16 Flat-head
bolt

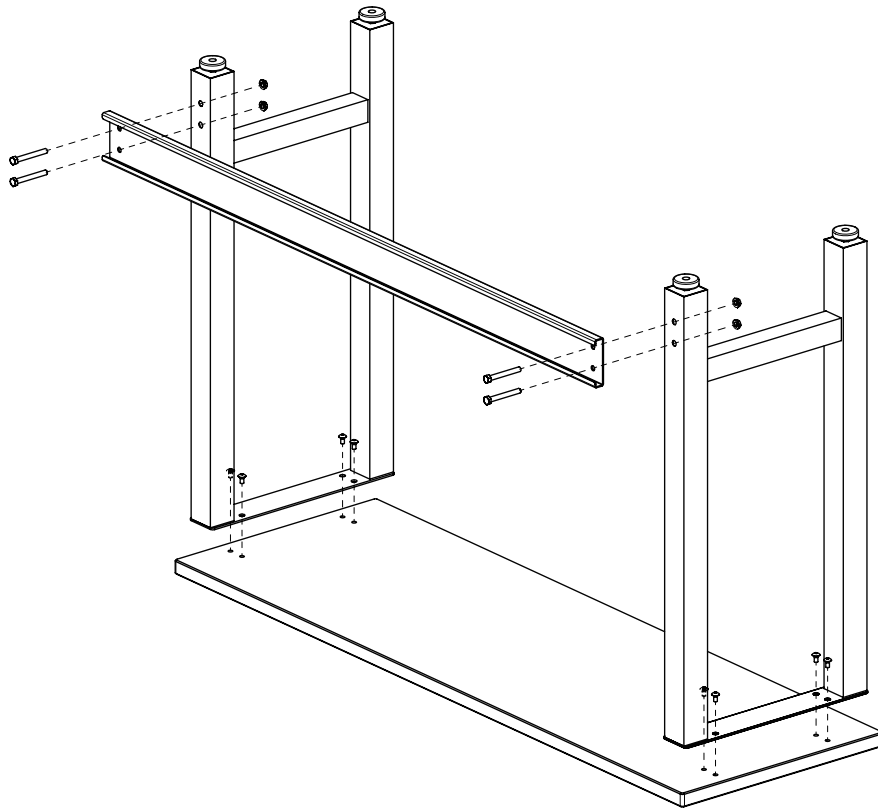

Setup

1. Planning the position of the cabinets, position the workbench

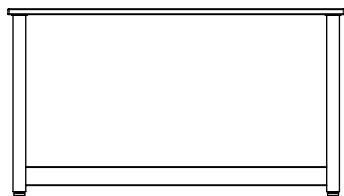

2. Align the pegboard and screw them onto the wall with

No. 2 x 4 each
Flat Washer

No. 4 x 4 each
M5 x 50mm Hex
Tapping Bolt

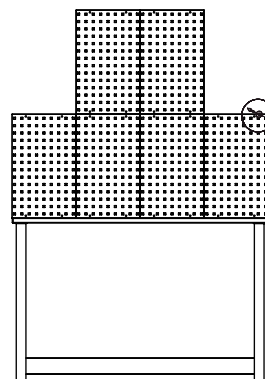
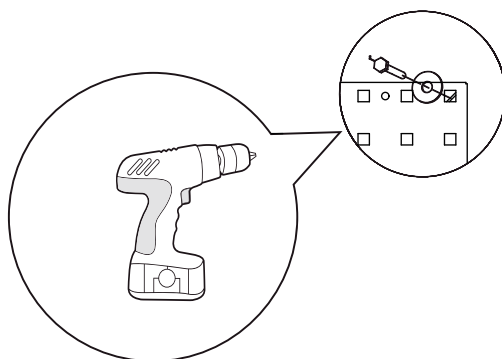

3. Connect the two wall cabinets with the shelves

No. 1 x 16
M6 Hex Flange Nut

No. 5 x 16
M6 x 12mm
Flat-Head Bolt

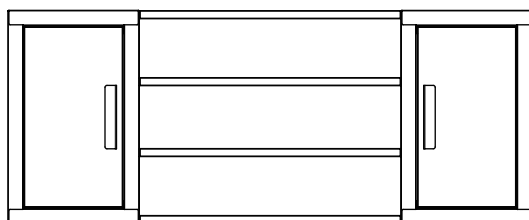

3. Open the door of the wall cabinet, connect the wall cabinet assembly to the wall. Two or more person is recommended for this step.

No. 2 x 8
Flat Washer

No. 4 x 8
M5 x 50mm Hex
Tapping Bolt

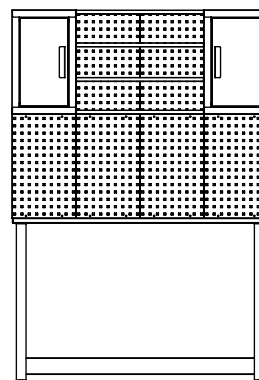
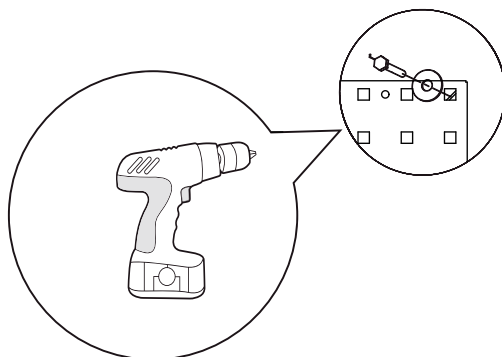

4. Roll the tool cabinet under the workbench

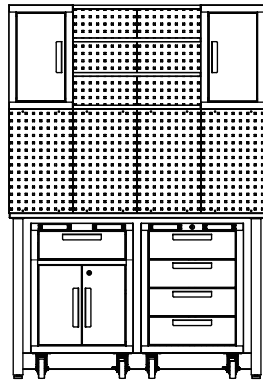

5. Lean the cabinet against the table. Open the door of the locker and securely attach the locker on the wall to prevent it from tipping.

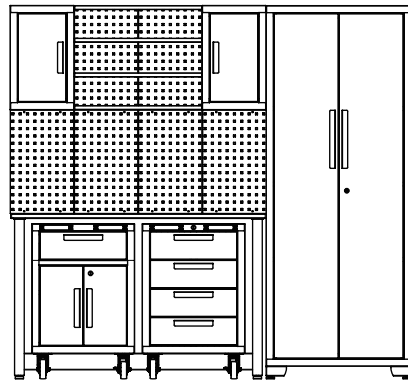

No. 2 x 4
Flat Washer

No. 4 x 4
M5 x 50mm Hex
Tapping Bolt

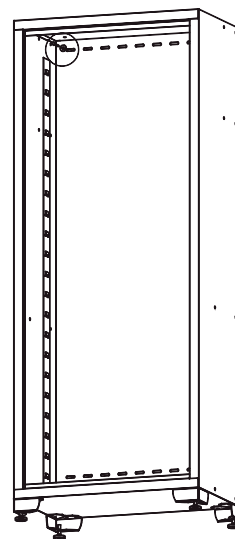
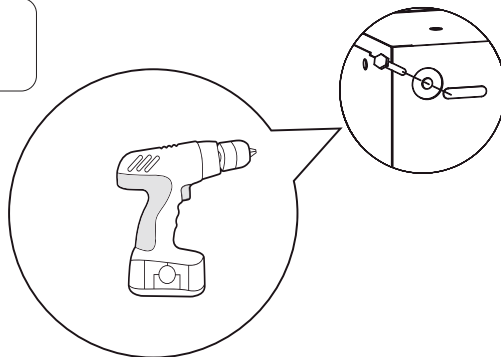

The installation of the garage cabinet set is finished.

Operation

Drawer Removal

Put the drawer out so that it's almost fully extended. Push up on the black release lever on one side, while pulling down on the black release lever on the other side. While holding the levers in the positions as illustrated below, pull the drawer outward until it is released from the drawer slide.

Push up one side

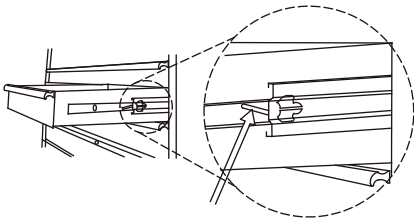

Push down the other side

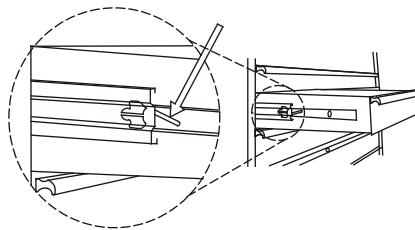

Drawer replacement

Extend the drawer slides from the cabinet. Insert the buckets on each side of the drawer into the slots in the slides, being careful to position them properly. Once inserted, close the drawer completely to seat the slides in their proper positions.

Maintenance

1. Lubricate the slides twice a year with a quality lubricant. This is especially necessary when the temperature drops, which may cause the bearings to be stiff.
2. Periodically clean the drawers fronts, doors, handles and other surfaces with mild soap and water.
3. For safety, use a non flammable cleaning fluid. Grease and oil can be removed with most standard cleaning fluids.