

SEALEY

720W BENCH PILLAR DRILL WITH DIGITAL DISPLAY & LASER GUIDE

MODEL NO: **PDM10B**

Thank you for purchasing a Sealey product. Manufactured to a high standard, this product will, if used according to these instructions, and properly maintained, give you years of trouble free performance.

IMPORTANT: PLEASE READ THESE INSTRUCTIONS CAREFULLY. NOTE THE SAFE OPERATIONAL REQUIREMENTS, WARNINGS & CAUTIONS. USE THE PRODUCT CORRECTLY AND WITH CARE FOR THE PURPOSE FOR WHICH IT IS INTENDED. FAILURE TO DO SO MAY CAUSE DAMAGE AND/OR PERSONAL INJURY AND WILL INVALIDATE THE WARRANTY. KEEP THESE INSTRUCTIONS SAFE FOR FUTURE USE.



Refer to instruction manual



Wear eye protection



Wear ear protection



Wear a mask

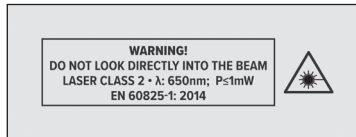

Warning!
Laser beam

1. SAFETY

1.1. ELECTRICAL SAFETY

- WARNING!** It is the user's responsibility to check the following:
Check all electrical equipment and appliances to ensure that they are safe before using. Inspect power supply leads, plugs and all electrical connections for wear and damage. Sealey recommend that an RCD (Residual Current Device) is used with all electrical products.

ELECTRICAL SAFETY INFORMATION. It is important that the following information is read and understood.

- 1.1.1. Ensure that the insulation on all cables and on the appliance is safe before connecting it to the power supply.
- 1.1.2. Regularly inspect power supply cables and plugs for wear or damage and check all connections to ensure that they are secure.
- 1.1.3. **IMPORTANT:** Ensure that the voltage rating on the appliance suits the power supply to be used and that the plug is fitted with the correct fuse - see fuse rating in these instructions.

- ✗ **DO NOT** pull or carry the appliance by the power cable.
- ✗ **DO NOT** pull the plug from the socket by the cable. Remove the plug from the socket by maintaining a firm grip on the plug.
- ✗ **DO NOT** use worn or damaged cables, plugs or connectors. Ensure that any faulty item is repaired or replaced immediately by a qualified electrician.

- 1.1.4. This product is fitted with a BS1363 3 pin plug.

If the cable or plug is damaged during use, switch off the electricity supply and remove from use.

Replace a damaged plug with a BS1363 3 pin plug. If in doubt contact a qualified electrician.

Class II products are wired with live (brown) and neutral (blue) only and are marked with the Class II symbol;

A) Connect the BROWN live wire to the live terminal 'L'.



B) Connect the BLUE neutral wire to the neutral terminal 'N'.

C) After wiring, check that there are no bare wires and ensure that all wires have been correctly connected.

Ensure that the cable outer sheath extends inside the cable restraint and that the restraint is tight.

DO NOT connect either wire to the earth terminal.

Sealey recommend that repairs are carried out by a qualified electrician.

If an extension reel is used it should be fully unwound before connection. A reel with an RCD fitted is preferred since any appliance plugged into it will be protected. The cable core section is important and

should be at least 1.5mm², but to be absolutely sure that the capacity of the reel is suitable for this product and for others which may be used in the other output sockets, we recommend the use of 2.5mm² section cable. If extension reel is to be used outdoors, ensure it is marked for outdoor use.

1.2. GENERAL SAFETY

- ✓ Familiarise yourself with the applications, limitations and potential hazards of the drill.
- ✓ Keep the operating instructions package with the machine at all times and store it in a plastic cover to protect it from dirt and moisture.
NOTE It is not designed for heavy commercial use.
- WARNING!** Disconnect the drill from the mains power before changing accessories, servicing or performing any maintenance.
- ✓ The machine must only be serviced by a qualified person or service agent. Contact your Sealey stockist for information.
- ✓ Select a work area suitable for the drill and keep the area clean, tidy and free from unrelated materials. Ensure that there is adequate lighting.
- ✓ Maintain the drill in good condition, check moving parts alignment regularly. Keep drill bits clean and sharp.
- ✓ Replace or repair damaged parts. *Use recommended parts only. Unauthorised parts may be dangerous and will invalidate the warranty.*
- WARNING!** Keep all guards and holding screws in place, tight and in good working order. Check regularly for damaged parts.
- ✓ A guard, or any other part, that is damaged should be repaired or replaced before the drill is next used. The safety guard is a mandatory fitting where the drill is used in premises covered by the Health & Safety at Work Act.
- ✓ Remove adjusting keys and wrenches from the machine and the vicinity before switching on.
- ✓ Operators must be under the adequate supervision of a person who has a thorough knowledge and experience of the machine and the appropriate regulations.
- ✗ **DO NOT** operate the drill if any parts are damaged or missing as this may cause failure and/or personal injury.
- ✗ **DO NOT** operate the drill when you are tired or under the influence of alcohol, drugs or intoxicating medication.
- ✓ When not in use switch off the drill and unplug from the power supply.
- WARNING!** Wear approved safety eye protection, ear defenders and, if dust is generated, respiratory protection.
- ✓ Remove ill fitting clothing. Remove ties, watches, rings and other loose jewellery and contain long hair.

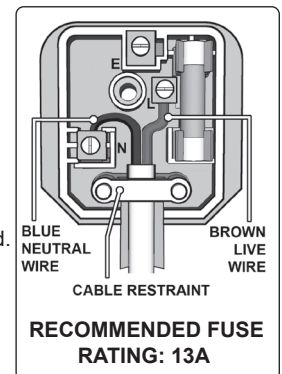

- ✓ Keep hands and body clear of the drill bit when operating the drill.
 - ✓ Maintain correct balance and footing. Ensure the floor is not slippery and wear non-slip shoes.
 - ✓ Keep children and unauthorised persons away from the work area.
 - ✓ Avoid unintentional starting and never leave the drill operating unattended.
 - ✗ **DO NOT** use the drill for a task it is not designed to perform and ensure operators are trained to use the drill.
 - ✗ **DO NOT** get the drill wet or use in damp or wet locations or areas where there is condensation.
 - ✗ **DO NOT** use the drill where there are flammable liquids, solids or gases such as paint solvents and including waste cleaning rags etc.
- 1.3. DRILL SAFETY WARNINGS**
- ✓ The work piece must be stationary and clamped or held against both the fence and the table.
 - ✓ Drill only one work piece at a time. Stacked multiple work pieces cannot be adequately clamped or braced and may bind on the drill bit or shift during cutting.
 - ✓ Ensure the drill is mounted or placed on a level, firm work surface before use. A level and firm work surface reduces the risk of the drill becoming unstable.
 - ✓ Always use a clamp or a fixture designed to properly support round material such as rods or tubing. Rods have a tendency to roll while being cut, causing the drill bit to "bite" and pull the work with your hand into the drill bit.
 - ✓ Let the drill bit reach full speed before contacting the work piece. This will reduce the risk of the work piece being thrown.
 - ✓ If the work piece or drill bit becomes jammed, turn the drill off. Wait for all moving parts to stop and disconnect the plug from the power source. Then work to free the jammed material. Continued drilling with a jammed work piece could cause loss of control or damage to the drill.
 - ✓ Never touch the drill bit or moving parts during use.
 - ✓ Never start the drill when the drill bit is in contact with the work piece.
 - ✓ The drill must be secured. A drill that is not properly secured may move or tip over and may result in personal injury.
 - ✗ **DO NOT** Drill pieces that are too small to be clamped securely. Holding the work piece by hand during operation may result in personal injury.
 - ✗ **DO NOT** Wear gloves. Gloves may be entangled by the rotating parts or chips leading to personal injury.
 - ✓ Keep your hands out of the drilling area while the tool is running. Contact with rotating parts or chips may result in personal injury.
 - ✓ Make sure the drill bit is rotating before feeding into the work piece. Otherwise the drill bit may become jammed in the work piece causing unexpected movement of the work piece and personal injury.
 - ✓ When the drill bit is jammed, stop applying downward pressure and switch off the tool. Investigate and take corrective actions to eliminate the cause of the jam. Jamming can cause unexpected movement of the work piece and personal injury.
 - ✓ Avoid generating long chips by regularly interrupting downward pressure. Sharp metal chips may cause entanglement and personal injuries.
 - ✓ Never remove chips from the drilling area while the tool is running. To remove chips, move the drill bit away from the work piece, switch off the tool and wait for the drill bit to stop moving. Use tools such as a brush or hook to remove chips. Contact with rotating parts or chips may result in personal injury.
 - ✓ **LASER LIGHT. DO NOT** stare into beam. Only turn laser beam on when tool is on work piece.
 - ✗ Never point the laser beam towards reflecting surfaces and persons or animals. Even a laser beam with a low output can cause damage to the eyes.
 - ▲ **DANGER:** Methods other than those specified here can result in dangerous radiation exposure.
 - ✗ Never open the laser module. Unexpected exposure to the beam can occur.
 - ✗ The laser may not be replaced with a different type of laser.
 - ✓ Repairs of the laser may only be carried out by the laser manufacturer or an authorised representative.

2. INTRODUCTION

Great workspace illumination and accuracy thanks to the integrated LED light and laser. Easy-to-read LCD display shows rpm as well as spindle travel for exact drilling depth. Parallel guide and vertical clamp on base. Superior control from two gears giving speed adjustment from 170 to 2600rpm. Convenient quick release chuck.

3. SPECIFICATION

Model noPDM10B
 Base size330mm x 300mm
 Collar Diameter: Ø43mm
 Column Diameter: Ø46mm
 Drilling Capacity (Chuck Size):..... 13mm
 Fuse Rating:..... 13A
 Integral Work Light:Yes, Including Laser Guide
 Maximum Distance Spindle to Base:..... 280mm
 Motor Power (Start):..... 720W(900W)
 Number of Speeds:2 Variable Speed Range : First : 170-880/min. Second : 490-2600/min
 Overall Height: 660mm
 Spindle Travel: 100mm
 Supply:.....230V
 Swing: 250mm

4. CONTENTS

- | | |
|--------------------------------|---|
| 1 drilling machine | 1 clamping lever (Fig1.6) |
| 1 quick release clamp (Fig1.2) | 1 depth stop (Fig1.7) |
| 1 base plate (Fig1.1) | 1 hex key, 4 mm (Fig1.19) |
| 1 guide / stop (Fig1.16) | 1 open-ended spanner (flat), 16 mm |
| 1 handle (Fig1.8) | 1 screw bag: 4 screws M8 x 50, 4 nuts M8, 8 washers |
| 1 chuck guard (Fig1.13) | 1 operating manual |
| 2 screws 3.0 x 12 | |

fig.1

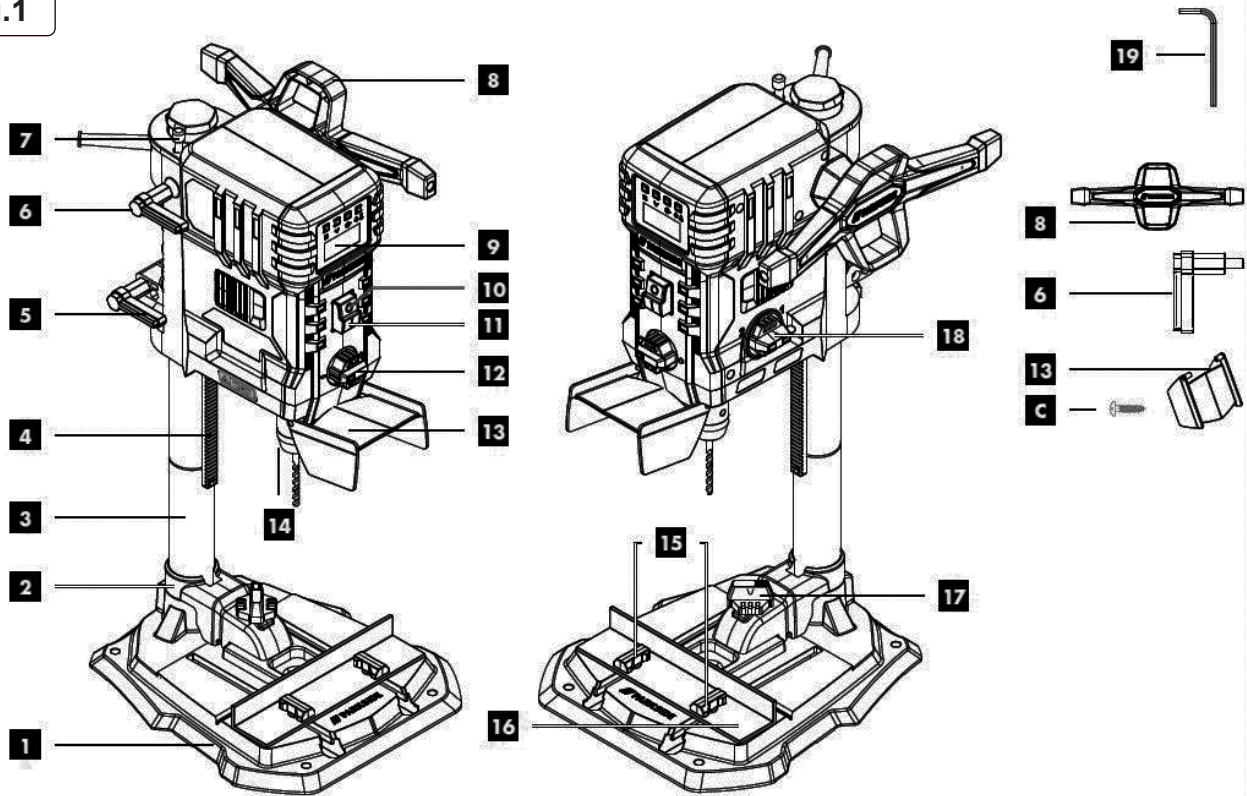

5. ASSEMBLY

- | | |
|---|-------------------|
| 1. Base plate | 8. Handle |
| 2. Quick clamp | 9. Display |
| 3. Column | 10. Off switch |
| 4. Toothed rack for height adjustment | 11. On switch |
| 5. Clamping lever for height adjustment | 12. Speed control |
| 6. Clamping lever for depth stop | 13. Chuck guard |
| 7. Depth stop | 14. Chuck |

- | |
|------------------------------------|
| 15. Winged screws for guide / stop |
| 16. Guide / stop |
| 17. Quick clamp lever |
| 18. Gear selector switch |
| 19. Hex key |

5.1. ASSEMBLING THE BASE PLATE AND COLUMN (fig.2)

- 5.1.1. Insert the quick release clamp (2) over the column (3).
- 5.1.2. Locate the column (3) into the base plate (1) so as the guide pins on the bottom end of the column (3) engage with the grooves, on the bottom of the base plate (1).
- 5.1.3. Secure the grub screws (A) on the rear of the base plate (1) with the hex key (19). This may need a further adjustment on completion to align laser light to ensure centralisation of the laser.

5.2. FITTING THE GUIDE / STOP (fig.3)

- 5.2.1. Slide the guide / stop (16) into the grooves in the base plate (1).
- 5.2.2. Ensure that the sliding blocks underneath the winged screws of the guide / stop (15) are properly engaged in the grooves of the base plate.
- 5.2.3. Move the guide / stop (16) to the desired position and tighten the winged screws of the guide / stop (15) firmly.

5.3. FITTING THE CHUCK GUARD (FIG.2)

- 5.3.1. Insert the chuck guard (13) into the holes provided in the machine frame.
- 5.3.2. Fit the chuck guard (13) and tightening the screws (C).

5.4. HANDLE FITMENT (fig.2)

- 5.4.1. Slide the handle (8) onto the retainer (D) as shown in fig.2.
- 5.4.2. Place the handle (8) on the retainer (D) with the flattened part at the side of the fastening screw (B).
- 5.4.3. Tighten the fastening screw (B) with the hex key (19).

5.5. FITTING THE DEPTH STOP (fig.2)

Insert the depth stop (7) into the hole provided in the housing.

5.6. CLAMPING LEVER FOR DEPTH STOP ASSEMBLY (fig. 2)

- 5.6.1. Assemble the clamping lever for depth stop (6) as shown in fig.2.

5.7. SECURING TO A WORK SURFACE (fig.3)

- 5.7.1. Fasten the device to the work surface by bolting the base plate (1) to the work surface.

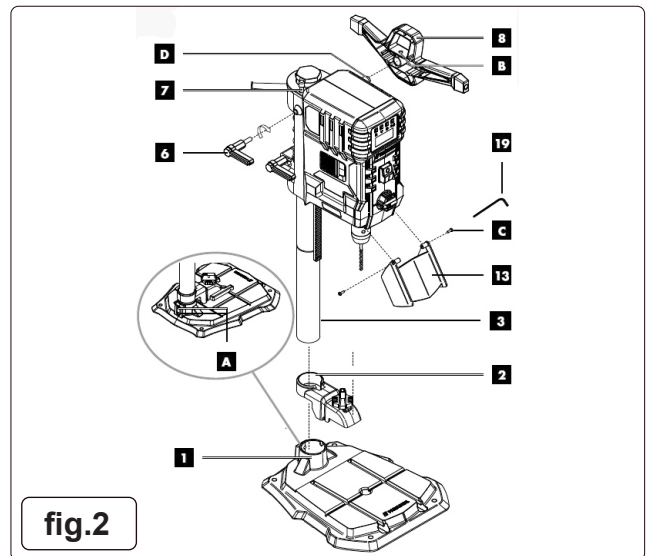

fig.2

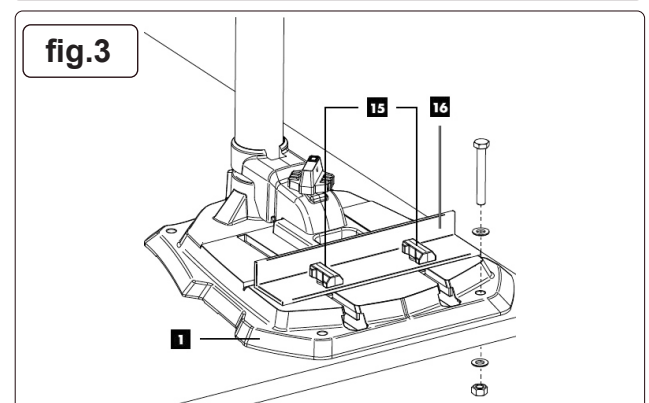

fig.3

6. OPERATION

6.1. OPERATION OF THE DISPLAY (fig. 4)

6.1.1. Switching the display on/off: Press the button one for five seconds until the display (9) switches on or off.

6.2. DISPLAY OF DRILLING DEPTH / SPEED

6.2.1. The display can be switched between displaying the speed and the drilling depth by pressing (F) button.

6.3. SETTING THE ZERO POINT

6.3.1. The zero point for the drilling depth can be set by pressing the (G) button.

6.4. SWITCHING THE LASER CROSS ON / OFF

6.4.1. The laser cross can be switched on or off by pressing the (H) button.

6.5. SWITCHING THE LED ON/OFF

6.5.1. The LED work light can be switched on or off by pressing the (I) button.

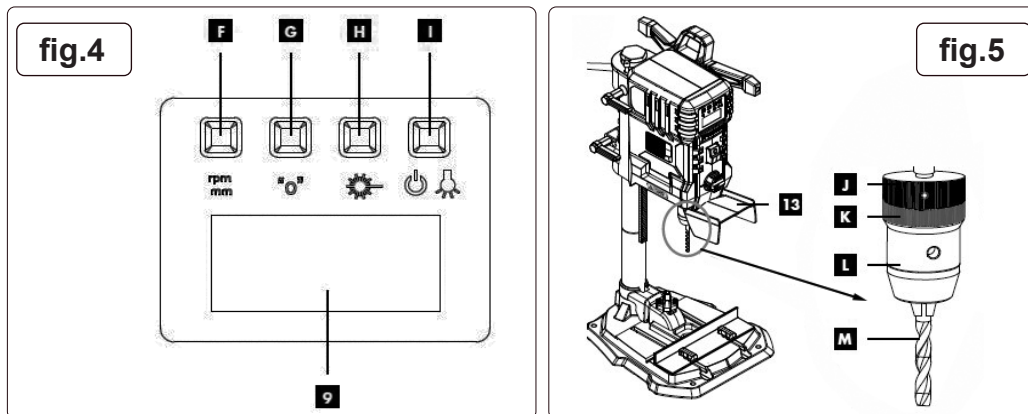

6.6. HEIGHT ADJUSTMENT (fig.1)

6.6.1. The position of the machine head can be adjusted to suit the work piece by height or length.

6.6.2. Hold the handle (8) firmly.

6.6.3. Release the clamping (5) lever for the height adjustment.

6.6.4. Set the position of the machine head with the handle (8).

6.6.5. Secure the position of the machine head with the clamping lever for height adjustment (5).

NOTE: Ensure in the lowest machine head position that the machine head will not be moved beyond the marking. Use the clamping lever for height adjustment (5) to secure the machine head in this position. Otherwise, the guide could be damaged.

6.7. SETTING THE DRILLING DEPTH (fig.1).

6.7.1. The drilling depth can be set with the depth stop (7).

6.7.2. Release the clamping lever on the depth stop (6).

6.7.3. Carry out a test drilling. As soon as the desired depth is shown on the display (9) (refer to point 10.9), tighten the depth stop clamping lever (6) again.

6.7.4. The depth stop (7) is now locked in the desired drilling depth.

6.8. CLAMPING/RELEASING DRILL BITS (fig 5 and fig 7)

6.8.1. CLAMPING

6.8.2. Hold the chuck in place and turn the securing ring (K) in the release direction.

6.8.3. Turn the clamping sleeve (L) clockwise until the drill bit (M) can be inserted. Hold the holding ring (J) in place whilst doing so.

6.8.4. Insert the drill bit (M), hold it in place and turn the clamping sleeve (L) counterclockwise by hand. Hold the holding ring (J) in place whilst doing so.

6.8.5. Hold the chuck in place and turn the securing ring (K) in the lock direction.

NOTE: When using small drill bits, set the chuck to roughly the right size for the drill bit beforehand. Otherwise, there is a risk of the drill bit not being properly centred in the chuck.

6.9. RELEASING

6.9.1. Turn the securing ring (K) in the "RELEASE" direction.

6.9.2. Turn the clamping sleeve (L) clockwise until the drill bit (M) can be removed.

6.10. ALIGNING WORK PIECES

6.10.1. Switch on the laser cross via the display (9). See 6.1, Operation of the display.

6.10.2. The intersection of the two laser lines exactly indicates the centre point of the drill.

6.10.3. Align your marking on the work piece with the laser cross.

6.11. CLAMPING THE WORK PIECE (fig. 6)

NOTE It must be possible to clamp the work piece securely. Do not work with work pieces that cannot be clamped securely. The cut out of the quick clamp must be centrally aligned with the hole to be drilled. Otherwise, the drill bit or the chuck could be obstructed by the quick clamp.

6.11.1. Position the work piece with the help of the laser cross.

6.11.2. Loosen the quick clamping lever (17).

6.11.3. Place the quick clamp (2) on the work piece.

6.11.4. Turn the quick clamp lever (17) clockwise to clamp the work piece. Turn the quick clamp lever (17) counterclockwise to release, the quick clamp (2).

6.12. CLAMPING LARGER WORK PIECES (FIG.6)

- 6.12.1. Use the parallel stop (16) for larger work pieces:
- 6.12.2. Loosen the wing screws for the parallel stop (15) and insert the parallel stop (16) into the grooves of the base plate.
- 6.12.3. Tighten the wing screws for the parallel stop (15).
- 6.12.4. Align your work piece against the parallel stop (16) and clamp it with the quick clamp (2).

NOTE: With work pieces that are wider or longer than the tabletop, ensure that these are adequately supported, e.g. through trestles or saw horses. Work pieces that are longer or wider than the base plate of the tabletop drill can tip if they are not properly supported. If the work piece tips, this can damage the chuck guard or the cutting tool.

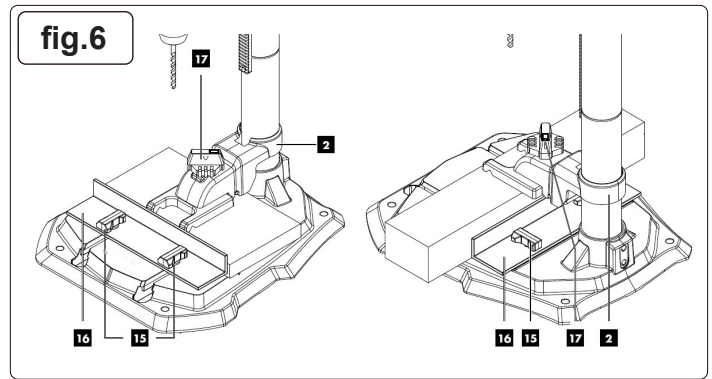

6.13. SETTING THE DRILLING SPEED (FIG. 1)

- 6.13.1. The correct speed must be set to suit the work piece to be drilled and the tool diameter.

6.14. MECHANICAL GEAR SELECTION

- 6.14.1. Two different speed ranges can be selected with the gear selector switch (18).
- 6.14.2. Low speeds first gear (170- 880 rpm) for large tool diameters.
- 6.14.3. High speeds second gear (490-2600 rpm) for small tool diameters.

NOTE: Actuate the gear selector switch (18) only when at a standstill. If the gear selector switch (18) does not latch into place turn the chuck (14) a little. If the gear selector switch (18) cannot be turned as far as the stop, turn the chuck a little with the drill.

6.15. ELECTRONIC SPEED CONTROL

- 6.15.1. The speed of the individual gears can be seamlessly adjusted with the electronic speed control. Set the speed with the help of the speed control (12). The current speed can be seen on the display (Fig 4.9).

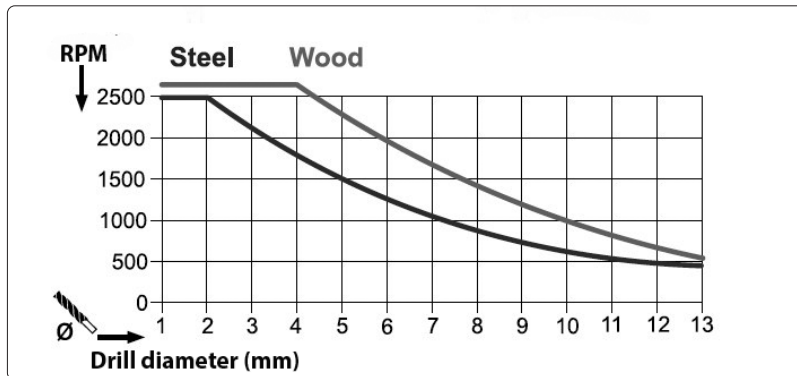

6.16. DISPLAYING THE DRILLING DEPTH (fig. 1.5)

- 6.16.1. Set the display (Fig 4.9) to the "Drilling depth" indication (button F).
- 6.16.2. Set the tip of the drill bit down lightly on the work piece.
- 6.16.3. Set the zero point by pressing the button (Fig. 4.) Drill until the desired depth is shown on the display Fig. 4.9)

6.16.4. SWITCHING ON/OFF (fig.1)

- 6.16.5. Make sure that the chuck guard (13) is folded down before switching on.
- 6.16.6. Switching on: Press the on switch (11) to switch the device on.
- 6.16.7. Switching off: Press the off switch (10) to switch the device off. G).

6.16.8. DRILLING PROCEDURE (fig. 1)

- 6.16.9. Align the work piece and clamp it.
- 6.16.10. Start the device and set the speed.
- 6.16.11. For drilling, move the handle (8) with uniform feed until the desired drilling depth is reached. When drilling into metal, interrupt the downward pressure briefly to break the swarf. After reaching the drilling depth, return the handle (8) to the starting position (5). Switch the device off.

7. MAINTENANCE

- WARNING!** Pull out the mains plug before carrying out any adjustments, maintenance or repair work. Let the device cool down before all maintenance and cleaning tasks.
NOTE: To transport the device hold it by the base plate (1).
Wipe swarf and dust off the machine from time to time with a cloth. Oil the rotating parts once monthly to extend the life of the tool.
 - DO NOT:** oil the motor.
 - DO NOT:** use corrosive agents for cleaning the plastic.
- 7.1. Before using the device each time, check the device for obvious defects such as worn or damaged parts, correct seating of screws or other parts. Replace damaged parts.
 - 7.2. **CLEANING**
 - DO NOT:** use cleaning agents or solvents. Chemical substances could damage the plastic parts of the device. Never clean the device under running water.
 - 7.2.1. Clean the device thoroughly after each use.
 - 7.2.2. Clean the ventilation holes and the surface of the device with a soft brush or cloth.
 - 7.2.3. Remove swarf, dust and dirt with a vacuum cleaner if necessary.
 - 7.2.4. Lubricate the moving parts regularly.

8. REPLACING THE CHUCK (FIG.7)

❑ **WARNING!** Pull out the mains plug!

8.1. TOOLS

8.1.1. Use an open-ended spanner (flat) 16 mm and one Hex key 2.5 mm (not included)

8.2. CHUCK REPLACEMENT

8.2.1. Loosen the Allen screw by turning it counterclockwise two turns. Hold the chuck shaft in place with the spanner and unscrew the chuck counterclockwise with your free hand.

8.2.2. Fasten the new chuck in reverse order.

NOTE: When replacing the chuck, use only chucks approved by the manufacturer.

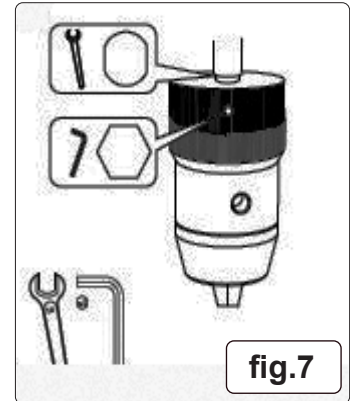

9. TROUBLESHOOTING

FAULT	POSSIBLE CAUSE	REMEDY
Device does not start.	Motor, cable or plug defective, building circuit Breaker tripped.	Check power outlet, mains connection cable, mains plug. Have repair carried out by electrical specialist. Check building circuit breakers and fuses.
	On/off switch (11/10) defective.	Contact authorised Sealey Stockist.
	Motor defective.	Contact authorised Sealey Stockist.
Heavy vibrations.	Base plate (1) not fastened in place.	Secure machine by tightening.
Motor overheats easily.	Drill bit not clamped centrally.	Check drill bit in chuck (Fig1.14).
Motor overheats easily.	Overloading of the motor, insufficient cooling of the motor.	Avoid overloading the motor while drilling, Remove dust from the motor in order to ensure optimal cooling of the motor.
Motor makes excessive noise.	Coils damaged, motor defective.	Have checked by customer service department.



WEEE REGULATIONS

Dispose of this product at the end of its working life in compliance with the EU Directive on Waste Electrical and Electronic Equipment (WEEE). When the product is no longer required, it must be disposed of in an environmentally protective way. Contact your local solid waste authority for recycling information.



ENVIRONMENT PROTECTION

Recycle unwanted materials instead of disposing of them as waste. All tools, accessories and packaging should be sorted, taken to a recycling centre and disposed of in a manner which is compatible with the environment. When the product becomes completely unserviceable and requires disposal, drain any fluids (if applicable) into approved containers and dispose of the product and fluids according to local regulations.



REGISTER YOUR PURCHASE HERE

Note: It is our policy to continually improve products and as such we reserve the right to alter data, specifications and component parts without prior notice.

Important: No Liability is accepted for incorrect use of this product.

Warranty: Guarantee is 12 months from purchase date, proof of which is required for any claim.

Sealey Group, Kempson Way, Suffolk Business Park, Bury St Edmunds, Suffolk. IP32 7AR

☎ 01284 757500

✉ sales@sealey.co.uk

🌐 www.sealey.co.uk