

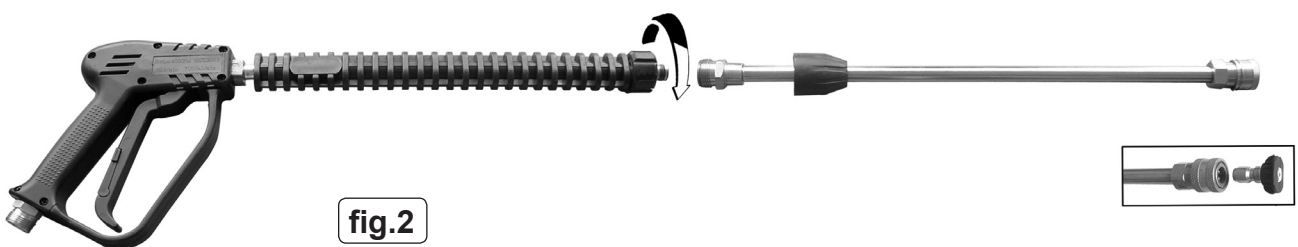

Petrol powered pressure washer with recoil starting. Ideal for commercial applications: with 5mtr pressure hose, 1mtr gun and lance and adjustable nozzle. Self priming pump makes this unit fully portable and can be used where no mains pressure is available. Can draw clean water from water butts and tanks etc. Low-pressure liquid detergent injection system with provision for detergent bottle stowage. Safety latch on trigger and automatic low-oil engine shutdown reduce risks of misuse and equipment damage. Unit stands on four legs, two with sucker feet to prevent creep, and tilts back onto two pneumatic tyred wheels for moving. Supplied with tools and full Instructions.

**fig.1**

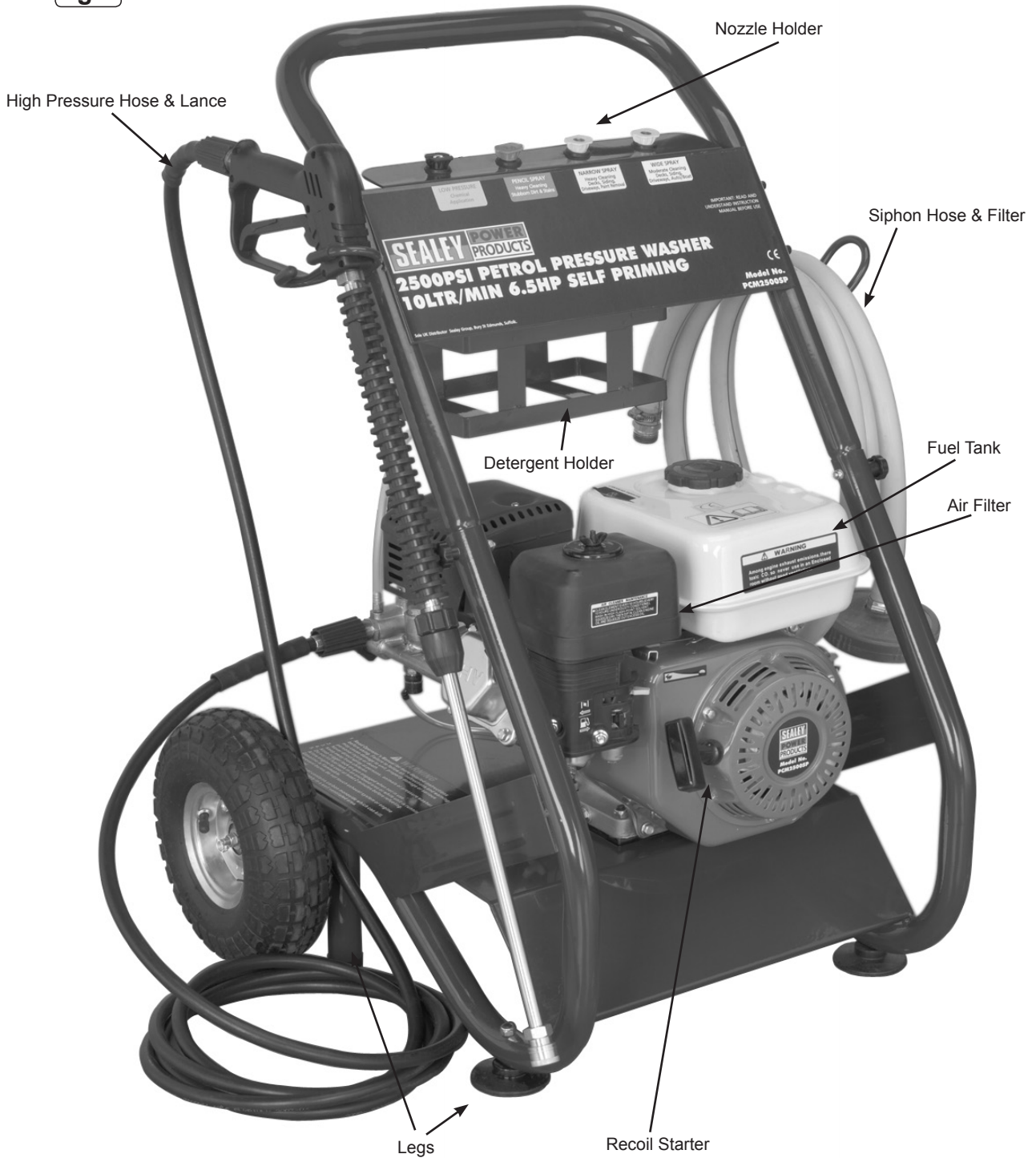

**fig.2**

### 3. ASSEMBLY / PRE-OPERATION

Unpack contents and check to ensure all parts are in good condition. If you experience any problems contact your dealer immediately.

#### 3.1 ASSEMBLY. (See fig.1.)

- 3.1.1 Screw together the two halves of the lance as shown in fig.2.  
3.1.2 Select an appropriate nozzle from the nozzle stowage area. Pull back the spring loaded sleeve at the end of the lance and insert the nozzle. Let go of the sleeve and check that the nozzle is firmly gripped in the fitting. The nozzle selection is colour coded and offers the following options.

BLACK Low pressure wide angle spray for use with detergent.  
RED High pressure, 0° degree spray, **Very Aggressive**. Use with extreme caution to prevent damage to the surface being cleaned or injury to persons or animals.  
YELLOW High pressure, 15° Spray angle, normal cleaning, provides a wide coverage and powerful water stream.  
WHITE High pressure, 40° Spray angle, normal cleaning and rinsing, provides a less powerful stream of water and is suitable for most general cleaning jobs.

fig.3

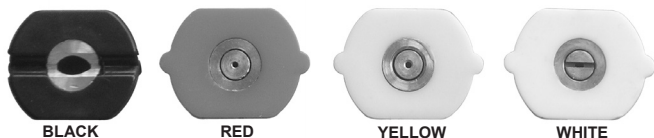

- 3.1.3 To attach the high pressure hose to the water inlet on the gun, push it into the inlet on the gun until it is fully seated and tighten as shown in figs.4 & 5.  
3.1.4 Attach the other end of the high pressure hose to the pump outlet as shown in fig.6. Push the end of the hose into the pump outlet until it is fully seated and then tighten to secure.  
3.1.5 Connect either a mains water supply hose or the siphon hose to the pump inlet as shown in fig.6. USE COLD WATER ONLY.

**Note:** The water supply hose must be reinforced and have an internal diameter of 13mm (1/2"). The minimum water supply rate must be at least equal to the washer flow rate.

The siphon pipe may require priming if drawing water from a level lower than the pump.

#### 3.2 DETERGENT DELIVERY.

- 3.2.1 Attach the BLACK low pressure nozzle to the end of the lance. Remove the cap from a bottle of detergent and place the bottle in the detergent holder.  
3.2.2 On the top of the pump outlet is a brass siphon injection fitting. Push the detergent input pipe onto the fitting (fig.6) and place the filter on the other end into the container of detergent ensuring that it goes all the way to the bottom. When used with the low pressure black nozzle detergent will be drawn from the container by siphonic action and will mix automatically with the water from the pump. Use Sealey General Purpose Detergent, **AK130 (25ltr)** or **AK131 (5ltr)**. Traffic Film Remover is also available, **AK132 (25ltr)** or **AK133 (5ltr)**.

#### 3.3 ENGINE LUBRICATION.

- 3.3.1 **THE PRESSURE WASHER ENGINE IS SHIPPED FROM THE FACTORY WITHOUT OIL. DO NOT ATTEMPT TO START THE ENGINE BEFORE THE SUMP HAS BEEN FILLED WITH THE CORRECT AMOUNT OF OIL.** Refer to the section 7.2.

#### 3.4 FUEL.

- 3.4.1 Fill the tank with fresh unleaded petrol fuel. Keep fuel level below the fuel filter which sits in the neck of the tank.

#### 3.5 PUMP.

- 3.5.1 The pump is supplied already filled with oil. Re-check the oil level before using the unit. The combined oil filler cap and dipstick is on top of the pump. The oil level can also be seen in the sight glass on the end of the pump.

#### 3.6 SITING OF UNIT.

- 3.6.1 Ideally the unit should be used on level ground. Where this is not possible the unit should not be inclined more than 20° in any one direction.

#### 3.7 RUNNING IN THE ENGINE.

- 3.7.1 For the first 20 hours of operation the unit should not be placed under heavy load. After the first 20 hours change the oil.

fig.4

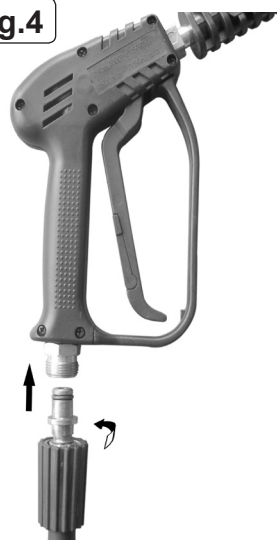

fig.5

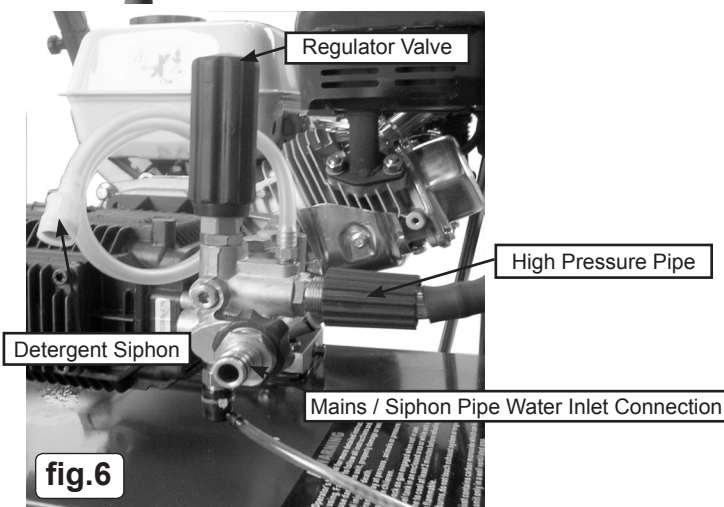

fig.6

### 4. SAFETY FEATURES

#### 4.1 THERMAL RELIEF VALVE.

- 4.1.1 A thermal relief valve is fitted to protect the machine from overheating if the gun remains closed for an extended period of time or if the nozzle becomes blocked. To prolong the life of the washer every effort should be made to avoid overheating. It is recommended that if the unit is not going to be used for two minutes or more it should be switched off.

#### 4.2 TRIGGER LOCK.

- 4.2.1 To prevent accidental starting of the pressure washer the trigger can be locked as shown in fig.4 by hinging out the lever built into the back of the trigger and pressing it until it locks into position. To release the locking lever flex the trigger handle forwards and flip the lever out and fold it back into the trigger. The trigger should be locked whenever the washer is not in use.

#### 4.3 LOW OIL SHUTDOWN.

- 4.3.1 The engine on this washer is equipped with a low oil shutdown feature which stops the engine if the oil drops below a specified level. Should the engine cut out, first check that it is standing on a level surface. If the oil level is still low top it up as described in Section 7.2.

### 5. OPERATION

- WARNING! THE PRESSURE WASHER ENGINE IS SHIPPED FROM THE FACTORY WITHOUT OIL.**
- WARNING! RISK OF FLUID INJECTION. This washer operates at fluid pressures and velocities high enough to penetrate human and animal flesh. If there is an occurrence of fluid injection seek medical help immediately.**
- WARNING! Ensure you read, understand and apply Section 1 safety instructions.**
- WARNING! Dry running can seriously damage the unit.**
- WARNING! DO NOT leave motor running for more than 2 minutes without operating the trigger, as temperature/pressure increase may damage sealing system.**

## 5.1. MANUAL STARTING PROCEDURE.

- 5.1.1 Check engine oil level before each use.
- 5.1.2 Check that the mains water feed hose is laid straight, and then fully open the water tap. Check to ensure there are no leaks from hoses or connections.
- 5.1.3 Release gun trigger safety catch and depress trigger to allow any air left in the system to escape, hold until there is a steady flow of water coming out and release the trigger.
- 5.1.4 Rotate the engine switch clockwise to the ON position. See fig.8.
- 5.1.5 Fig.7 shows the fuel tap in the OFF position. Push the fuel tap up to the right to the open position.
- 5.1.6 If the engine is cold move the choke lever to the left to close the choke.
- 5.1.7 Move the throttle lever slightly to the left, fig.7 shows the throttle in the full throttle position.
- 5.1.8 Turn the engine switch to the ON position.
- 5.1.9 Take hold of the recoil starter handle (see fig.1) and pull it slowly until you feel resistance, then let it return slowly.
- 5.1.10 Now pull the starting handle hard and fast all the way out. Use two hands if necessary.
- 5.1.11 If the engine doesn't start repeat the process from 5.1.9.
- 5.1.12 Once started adjust throttle valve to the required setting and return the choke to the open position when the engine is warm.

## 5.2. CLEANING

- 5.2.1 Only apply detergent using the BLACK low pressure nozzle.
- 5.2.2 Depress the trigger to apply the detergent to the *dry surface* which is to be cleaned.  
Vertical surfaces should be cleaned from the bottom upwards.
- 5.2.3 When detergent application is complete remove the syphon tube from the detergent container and place it in a container of clean water. Run the washer at low pressure to purge the gun of detergent.
- 5.2.4 Leave the detergent to act for 1-2 minutes, but **DO NOT** allow the surface to dry.

- 5.2.5 The detergent should be rinsed off using either the YELLOW or WHITE high pressure nozzles depending on the spray angle required. **Do not use the RED nozzle as the aggressive spray action may erode the surface being cleaned.** Always lock the gun trigger before changing nozzles.
- 5.2.6 Hold the gun firmly with both hands and commence washing with high pressure clean water. When rinsing work from the top to the bottom to avoid streaks.

**Note:** Care should be taken when selecting the nozzle for the job in hand. The distance from the nozzle to the surface being cleaned will depend on the condition of that surface. Always start further away and slowly move closer until the level of cleaning required is achieved.

## 5.3. SHUT DOWN PROCEDURE.

- 5.3.1 When cleaning has finished and the unit is no longer required allow the engine to run unloaded for 2 minutes before shutting down.
- 5.3.2 Stop the engine by pushing the throttle lever fully to the right. (See fig.7) and turn the engine switch to the OFF position.
- 5.3.3 Turn off the fuel tap. (See fig.7)
- 5.3.4 Turn off the mains water supply.
- 5.3.5 Discharge residual pressure from the washer by pressing the trigger until no more water comes out of the nozzle.
- 5.3.6 Engage the gun trigger safety catch.
- 5.3.7 In an emergency turn the engine switch to the OFF position.

### ☐ CAUTION!

- a) Avoid sudden bursts of water as this will cause the water pressure to drop and put extreme pressure on the hoses and connections.
- b) If another person is using water from the same supply as the washer, the water pressure will drop and the washer will not operate correctly. Switch the engine off immediately and wait until the pressure is restored.

## 6. MAINTENANCE (WASHER)

**Maintenance should only be performed with the engine turned off and the unit disconnected from the mains water supply.**

- 6.1 **CLEANING THE NOZZLES:** Pull back the brass sleeve on the end of the lance and pull out the nozzle. Clean the nozzle with wire provided (fig 9). If this does not improve the flow from the nozzle it should be replaced.

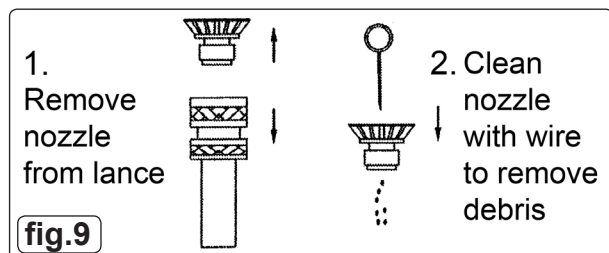

- 6.2 Check and clean the water inlet filter every 50 operating hours. The filter is moulded into a rubber washer. Unscrew the brass connector from the black fitting on the water inlet on the pump. Push the black fitting backwards which will eject the filter/washer and then clean the filter washer. If the filter is damaged in any way it should be replaced.
- 6.3 Check and clean the detergent filter at the end of the detergent input tube on a regular basis.
- 6.4 **WINTER STORAGE:** Fill the pump with an antifreeze mixture before storing in a frost free, safe, dry area for the winter. Introduce the antifreeze by the following method.
  - 6.4.1 Shut off the water supply and disconnect the supply hose. Relieve pressure within the pump by squeezing the gun trigger. Remove the high pressure hose and let all water drain from it. Hold gun/lance with nozzle downwards and pull trigger until all water has drained out.
  - 6.4.2 Connect a short length of garden hose to the water inlet and using a funnel pour an antifreeze mixture into it.
  - 6.4.3 Pull the recoil starter several times to circulate the antifreeze through the pump. Continue to add antifreeze and pull the recoil until antifreeze is expelled from the pump.

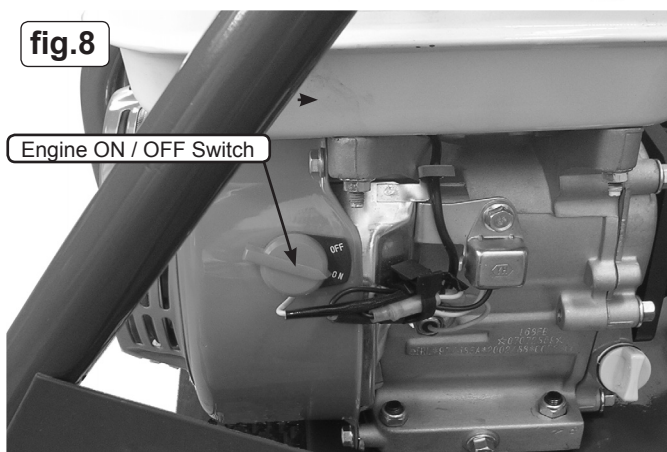
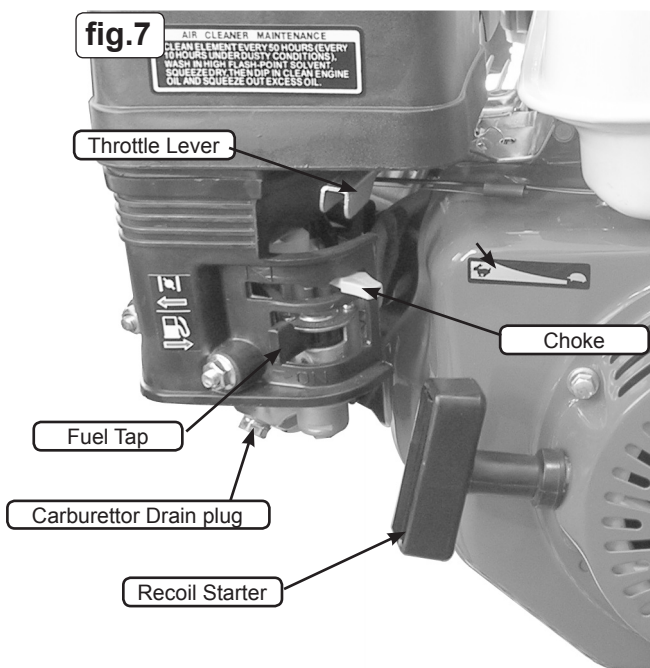

## 7. MAINTENANCE (ENGINE)

- 7.1** Change engine oil after the first 20 hours of operation. Thereafter, change oil every six months or every 100 hours of operation. Change oil more often if engine is operated under heavy load, or in high ambient air temperatures. During normal operation, partially burned fuel, small particles of metal from the cylinder walls, pistons, bearings and combustion deposits will gradually contaminate the oil. If the oil is not changed regularly, these foreign particles can cause increased friction and a grinding action which shortens the life of the engine. Fresh oil also assists in cooling. Old oil gradually becomes thick and loses its cooling ability as well as its lubricating qualities.

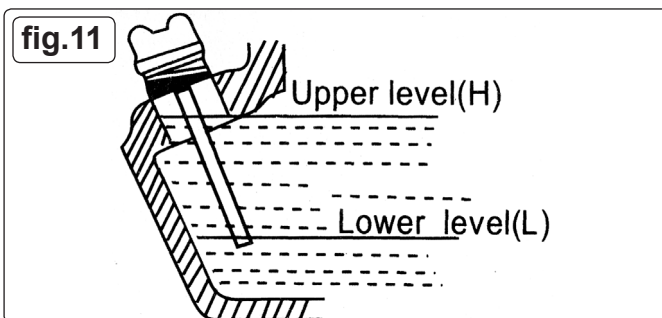
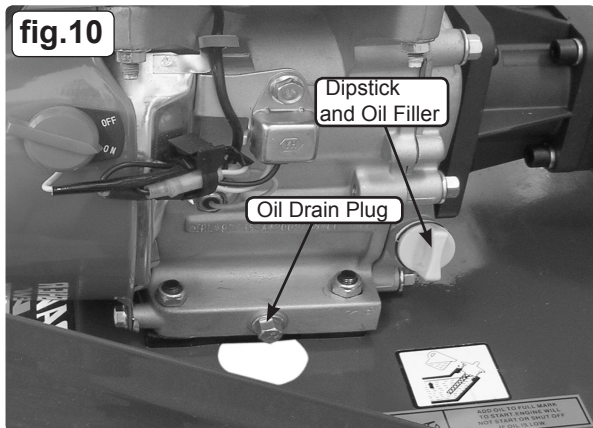

- 7.2 CHECKING THE OIL LEVEL.** Ensure the unit is on a level surface.
- 7.2.1** Unscrew the dipstick/oil filler cap (see fig.10) and wipe it clean of oil. Note that the maximum oil level should be just below the opening of the filler neck.
- 7.2.2** Check the oil level by seating the dipstick into the hole without screwing it in. See fig.11 above. On removal the oil level should be between the two marks on the dipstick. If it is at the lowest level or below, top-up immediately with an SAE10W30 oil.
- 7.2.3** Screw dipstick fully home to seal oil fill hole.
- Note:** The engine is fitted with a low oil sensor which will automatically shut the engine down in a low oil situation. The sensor may also operate if the unit is not on a level surface.
- 7.3 CHANGING THE OIL.**
- 7.3.1** Change the oil. Operate the engine for 3 minutes to warm the oil then stop the engine using the shut down procedure described in section 5.3. There is a hole in the chassis below the oil drain plug. See fig.10. Place a suitable container below the hole, remove the plug and allow the oil to drain. Replace the drain plug and refill with fresh oil. Check the oil level using the dipstick. Dispose of the old oil according to local authority guidelines.
- 7.4 FUEL FILTER:** The fuel filter is in the neck of the fuel tank.
- 7.4.1** Clean it every 300 hours.

- 7.5 ENGINE STORAGE.** If the unit is not to be used for more than one month the following procedure should be followed.
- 7.5.1** Drain the fuel from the fuel tank, fuel line and fuel tap.
- 7.5.2** Ensure that the engine switch is in the off position and pull the recoil starter handle slowly until an increase in pressure is felt indicating that the piston has commenced its compression stroke and leave it in this position. This closes both the intake and exhaust valves and prevents the inside of the cylinder from rusting.
- 7.5.3** Cover the unit and store it in a clean dry place that is well ventilated and away from open flame or sparks.



- 7.6 AIR FILTER.** To access the air filter element unscrew and remove the wing nut and seal washer on the top of the cover. Lift the air filter off its threaded mounting rod.
- 7.6.1** Remove the metal retainer and the foam filter from the inside of the outer air filter casing.
- 7.6.2** Wash the foam element with a household detergent or a high flash-point solvent and squeeze dry. When the element is thoroughly dry soak it in clean engine oil. Squeeze out any excess oil, fit back into the outer casing and replace the metal retainer.
- 7.6.3** Place the air filter back over the threaded rod and secure with the seal and wing nut.
- 7.6.4** The foam element should be replaced after every 300 hours of service.



- 7.7 CARBURETTOR.** To adjust the idling speed, turn the throttle adjusting screw (fig.14) clockwise to increase and anti-clockwise to decrease engine speed. Standard idling speed: 1700 +/- 15rpm
- 7.7.1** To clean the deposit cup (fig.14), set the fuel tap to OFF, undo the central bolt and lower the deposit cup, take care not to spill any fuel, dispose of old fuel in accordance with local authority guidelines. Wash components in a non-flammable or high flash point cleaning solvents, dry components and refit components in reverse order. Turn fuel tap back ON and check for leaks.
- 7.8 SPARK PLUG.** To remove the spark plug, pull off the spark plug lead (fig.15) and remove the spark plug (fig.16) using the spark plug wrench supplied (fig.18).
- Note:** Care must be taken if the engine is hot due to the close proximity of the exhaust silencer to the spark plug.
- 7.8.1** Clean spark plug using a wire brush and check the insulator for damage, replace if damaged or at service schedule.
- 7.8.2** Check the electrode clearance (fig.17) with a feeler gauge, adjust if required using a plug gap tool.
- 7.8.3** Replace spark plug and refit plug lead.

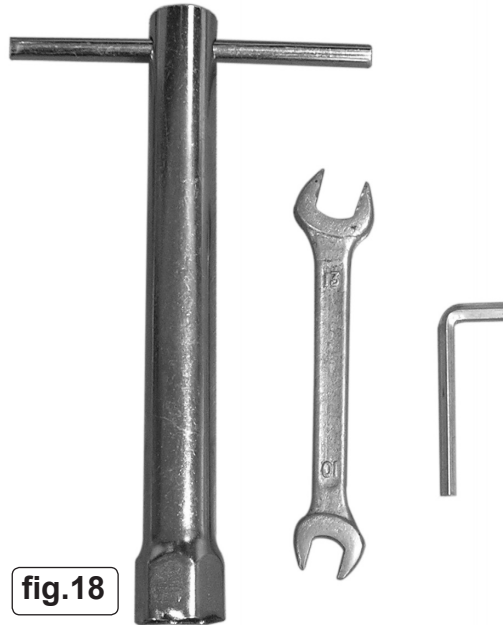
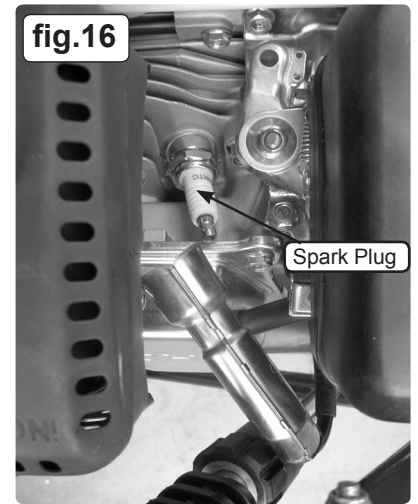
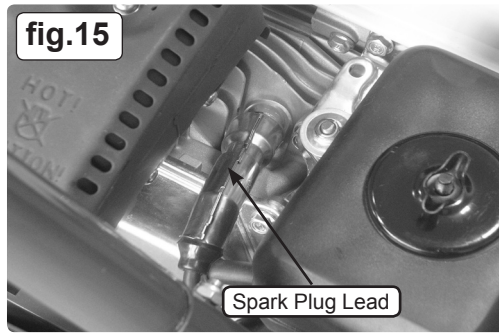
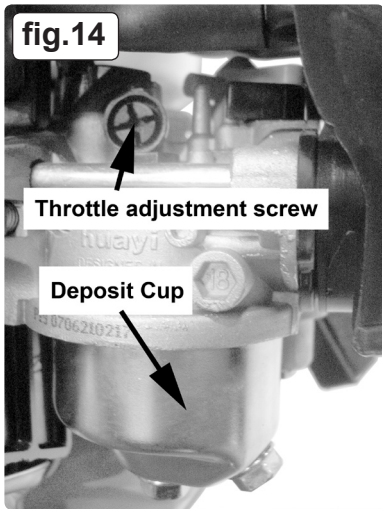

## 8. ENGINE MAINTENANCE SCHEDULE

Operation Hours		Daily	First Month or 20hrs	Every 3 months or 50hrs	Every 6 months or 100 hrs	Every 12 months or 300hrs
Task						
Check and tighten nuts and bolts	Check	✓				
Engine oil	Oil Level Check	✓				
	Replace		✓		✓	
Replace air cleaner element	Check	✓				
	Clean			✓	✓	
	Replace					✓
Spark Plug	Clean / Adjust				✓	
	Replace					✓
Fuel Tank & Fuel Filter	Clean					✓
Fuel Supply Line	Check		Every 2 years (replace if required)			
Carburettor Deposit Cup	Clean				✓	
Idling	Check / Adjust					✓
Intake and exhaust valve clearances	Check / Adjust					✓

## 9. GENERAL TROUBLESHOOTING

PROBLEM	POSSIBLE CAUSES	REMEDY
Engine will not start	Low oil sensor has shut down engine	Top up oil level
	Engine Switch not in the ON position	Turn switch ON
	Pressure build up in pump	Operate trigger
Engine is overloaded	Nozzle partially blocked	Clean nozzle
	Excessive pressure build up	Return to Sealey dealer to have reflux valve adjusted
Engine running, but pump not building maximum pressure or has irregular pressure	Mains water turned off or insufficient supply	Turn on mains water or increase supply
	Unit has been stored in freezing temperatures	Thaw out completely including hose, gun and wand
	Water inlet filter clogged	Clean out filter
	Kink in water supply hose	Straighten out hose
	Lance nozzle worn or damaged	Replace nozzle
No intake of detergent	Air in pump	Refer to section 5.1 - 5.1.3 and bleed air out of system
	Injection tube not properly attached to unit	Push tube firmly on to siphon nozzle
	Tube cracked or split	Replace tubing
	High pressure nozzle fitted	Fit low pressure nozzle (BLACK)
Trigger will not move	Siphon nozzle blocked	Clean nozzle
	Trigger lock engaged	Release trigger lock
Noisy operation	Worn bearings	Return to Sealey dealer for bearing replacement
	Tappet clearances excessive	Return to Sealey dealer for servicing.
	Cavitation in pump	Check inlet hose for correct size or leaks
Rough / pulsating operation with pressure drop	Inlet restriction	Check inlet hose for correct size, blockages or leaks
	Cavitation in pump	Check inlet hose for correct size or leaks
Engine running hot	Wrong grade of oil	Use recommended oil
	Oil too high / low	Adjust oil level to recommended level

**NOTE:** It is our policy to continually improve products and as such we reserve the right to alter data, specifications and component parts without prior notice.

**IMPORTANT:** No liability is accepted for incorrect use of this product.

**WARRANTY:** Guarantee is 12 months from purchase date, proof of which will be required for any claim.

**INFORMATION:** For a copy of our latest catalogue and promotions call us on 01284 757525 and leave your full name and address, including postcode.



Sole UK Distributor, Sealey Group,  
Kempson Way, Suffolk Business Park,  
Bury St. Edmunds, Suffolk,  
IP32 7AR



01284 757500



01284 703534



www.sealey.co.uk



sales@sealey.co.uk