



INDUSTRIAL VACUUM CLEANER WITH AUTO START/STOP

INSTRUCTION MANUAL FOR MODEL: PC300SDAUTO.V3

Thank you for purchasing a Sealey product. Manufactured to a high standard this product will, if used according to these instructions and properly maintained, give you years of trouble free performance.

IMPORTANT: PLEASE READ THESE INSTRUCTIONS CAREFULLY. NOTE THE SAFE OPERATIONAL REQUIREMENTS, WARNINGS, AND CAUTIONS. USE THIS PRODUCT CORRECTLY, AND WITH CARE FOR THE PURPOSE FOR WHICH IT IS INTENDED. FAILURE TO DO SO MAY CAUSE DAMAGE AND/OR PERSONAL INJURY AND WILL INVALIDATE THE WARRANTY.

1. SAFETY INSTRUCTIONS

1.1 ELECTRICAL SAFETY

WARNING! It is the responsibility of the owner and the operator to read, understand and comply with the following: You must check all electrical products, before use, to ensure that they are safe. You must inspect power cables, plugs, sockets and any other connectors for wear or damage. You must ensure that the risk of electric shock is minimised by the installation of appropriate safety devices. A Residual Current Circuit Breaker (RCCB) should be incorporated in the main distribution board. We also recommend that a Residual Current Device (RCD) is used. It is particularly important to use an RCD with portable products that are plugged into a supply which is not protected by an RCCB. If in any doubt consult a qualified electrician. You may obtain a Residual Current Device by contacting your Sealey dealer. You must also read and understand the following instructions concerning electrical safety.

- 1.1.1 The **Electricity at Work Act 1989** requires that all portable electrical appliances, if used on business premises, are tested by a qualified electrician, using a Portable Appliance Tester (PAT), at least once a year.
- 1.1.2 The **Health & Safety at Work Act 1974** makes owners of electrical appliances responsible for the safe condition of those appliances and the safety of the appliance operators. **If in any doubt about electrical safety, contact a qualified electrician.**
- 1.1.3 Ensure that the insulation on all cables and on the appliance is safe before connecting it to the power supply. See 1.1.1. and 1.1.2. and use a Portable Appliance Tester.
- 1.1.4 Ensure that cables are always protected against short circuit and overload.
- 1.1.5 Regularly inspect power supply cables and plugs for wear or damage and check all connections to ensure that none is loose.
- 1.1.6 **Important:** Ensure that the voltage marked on the appliance matches the power supply to be used and that the plug is fitted with the correct fuse - see fuse rating at right.
- 1.1.7 **DO NOT** pull or carry the appliance by the power cable.
- 1.1.8 **DO NOT** pull the plug from the socket by the cable.
- 1.1.9 **DO NOT** use worn or damaged cables, plugs or connectors. Immediately have any faulty item repaired or replaced by a qualified electrician. When a BS 1363/A UK 3 pin plug is damaged, cut the cable just above the plug and dispose of the plug safely.

Fit a new plug according to the following instructions (UK only).

- a) Connect the **GREEN/YELLOW earth wire** to the earth terminal 'E'.
- b) Connect the **BROWN live wire** to the live terminal 'L'.
- c) Connect the **BLUE neutral wire** to the neutral terminal 'N'.
- d) **After wiring, check that there are no bare wires, that all wires have been correctly connected, that the cable outer insulation extends beyond the cable restraint and that the restraint is tight.**

Double insulated products, which are always marked with this symbol , are fitted with live (brown) and neutral (blue) wires only. To rewire, connect the wires as indicated in diagram. **DO NOT** connect either wire to the earth terminal.

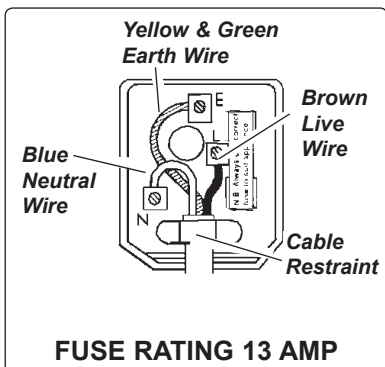

- 1.1.10 Products which require more than 13 amps are supplied without a plug. In this case you must contact a qualified electrician to ensure that a suitably rated supply is available. We recommend that you discuss the installation of an industrial round pin plug and socket with your electrician.
- 1.1.11 If an extension reel is used it should be fully unwound before connection. A reel with an RCD fitted is preferred since any appliance plugged into it will be protected. The cable core section is important and should be at least 1.5mm², but to be absolutely sure that the capacity of the reel is suitable for this product and for others which may be used in the other output sockets, we recommend the use of 2.5mm² section cable.

1.2 GENERAL SAFETY

- ✓ Disconnect the cleaner from the power supply before servicing, changing accessories, or performing any maintenance.
- ✓ Use only genuine parts and accessories. Unauthorised parts and accessories may be dangerous and will invalidate your warranty.
- ✓ Maintain the cleaner in good condition. Use an authorised agent for servicing. Keep machine clean, but **DO NOT** use solvents.
- x **DO NOT** operate the unit without the locking cartridge filter in place (except when wet vacuuming when the foam sleeve filter is used). **Using the cleaner without a locking cartridge filter will cause machine faults and will invalidate your warranty.**
- ✓ Wear protective clothing and gloves.
- x **DO NOT** allow children or untrained persons to operate the cleaner.
- x **DO NOT** place attachments close to your face (especially eyes, ears, etc). Do not point the hose end at other persons or animals.
- ▲ **DANGER! DO NOT** vacuum hot or glowing ash, cigarette ends, inflammable, explosive, corrosive or other dangerous substances.
- x **DO NOT** leave machine running unattended. Turn power supply OFF and **DO NOT** leave the vicinity until motor has come to a complete stop.
- x **DO NOT** operate the cleaner while under the influence of drugs, alcohol or impairing medication, or if you are tired.
- x **DO NOT** use the cleaner in the rain or in very damp conditions.
- x **DO NOT** use the cleaner for a task it is not designed to perform.

2. INTRODUCTION & SPECIFICATION

Introduction: Powerful 1400Watt motor head gives incredible suction through Ø35mm hosing. May also be used as a blower. Integral three-pin BS socket provides power supply for dust-free tools up to 1400W. When used in conjunction with a power tool the cleaner auto-starts when the tool is started and auto-stops 10 seconds after the tool is switched off - to ensure tool and hose are left free of dust. Includes stainless steel drum on two castors and two fixed wheels & stainless steel telescopic rigid extension tube as well as tools for wet and dry operations. Tool stowage points on head and base. Supplied with cartridge filter and wet-use foam filter.

Specification

Motor:	230V 1400W
Container	30ltr
Weight	9kg
Vac Accessories Ø:	35mm
Max vacuum pressure	165mbar
Air flow	120m ³ /hr
Filter type	Locking Cartridge

3. CONTENTS

- 3.1 **Carton content**
 3.1.1 Carefully unpack the carton.
 3.1.2 Locate the two side latches (fig. 1.19) which hold the power head in place.
 3.1.3 Undo the latches, remove the top section and take out the items in the container.
 3.1.4 Check and identify each component as listed below. If anything is missing or damaged please contact your supplier immediately.

Item	Description	Item	Description
1	Flexible vacuum hose	12	Dust free tool socket
2	Combination nozzle	13	Handle
3	Telescopic suction tube	14	Function switch
4	Vacuum hose connection	15	Latch (2)
5	Crevice nozzle	16	Wheel (2)
6	Noise diffuser	17	Castors (2)
7	Dust free tool adaptor Part No:PC200SDAV3.43	18	Drain cap
8	Foam filter	19	Axle
9	Locking Cartridge filter (fitted as standard)	20	Washers (4)
10	Container, (Stainless Steel)	21	'R' clip (2)
11	ON/OFF switch	22	Hub caps (2)

4. ASSEMBLY

- 4.1 Ensure the mains plug is disconnected.
 4.2 Undo latches that secure the power head to the stainless container.
 4.3 Lift off the power head and put carefully to one side.
 4.4 Locate the castors and wheels ready for assembly.
 4.5 Turn the container upside down. Push the castor spindles fully home into the mounting collars provided on the underside of the lower moulding.
 4.6 Push the rear axle tube through the mounting points provided at the back of the lower moulding so that it protrudes equally at either end. Slide a washer over each end of the axle followed by a wheel and another washer. Retain the wheels and washers by inserting an 'R' clip through the holes in each end of the axle tube. Snap a hub cap into place on each wheel.
 4.7 For dry vacuum cleaning use the locking cartridge filter supplied. **NOTE: Do not operate the cleaner without a cartridge filter fitted as this will damage the machine and invalidate your warranty. Ensure the filter is correctly fitted before every use.**
 4.8 If wet vacuuming remove the cartridge filter and push the foam filter over the filter basket instead.
 4.9 Replace the top section onto the container.
 4.10 Align up the top section with the latches and snap into place, by applying pressure at the mid point of the clasps.
 4.11 For quiet operation insert the noise diffuser (fig.1-6) into the blower port and push it firmly home.
 4.12 Screw the large end of the vacuum hose into the front inlet of the container.
 4.13 Choose the desired nozzle and push it onto the telescopic suction tube.

5. SWITCH OPERATION

OPERATE VACUUM ONLY

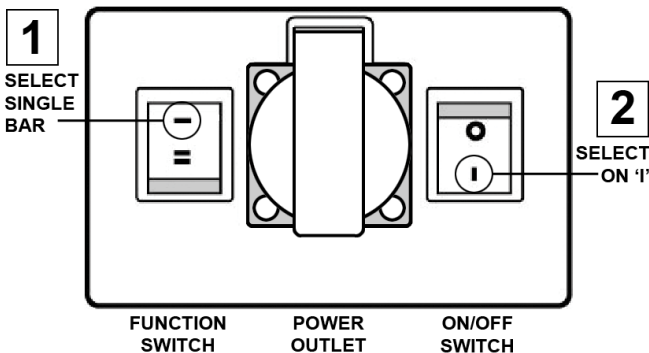

- 5.1 **OPERATE VACUUM ONLY.**
 5.1.1 Select single bar position on function switch.
 5.1.2 Move the ON/OFF switch to ('I') position to start the cleaner.

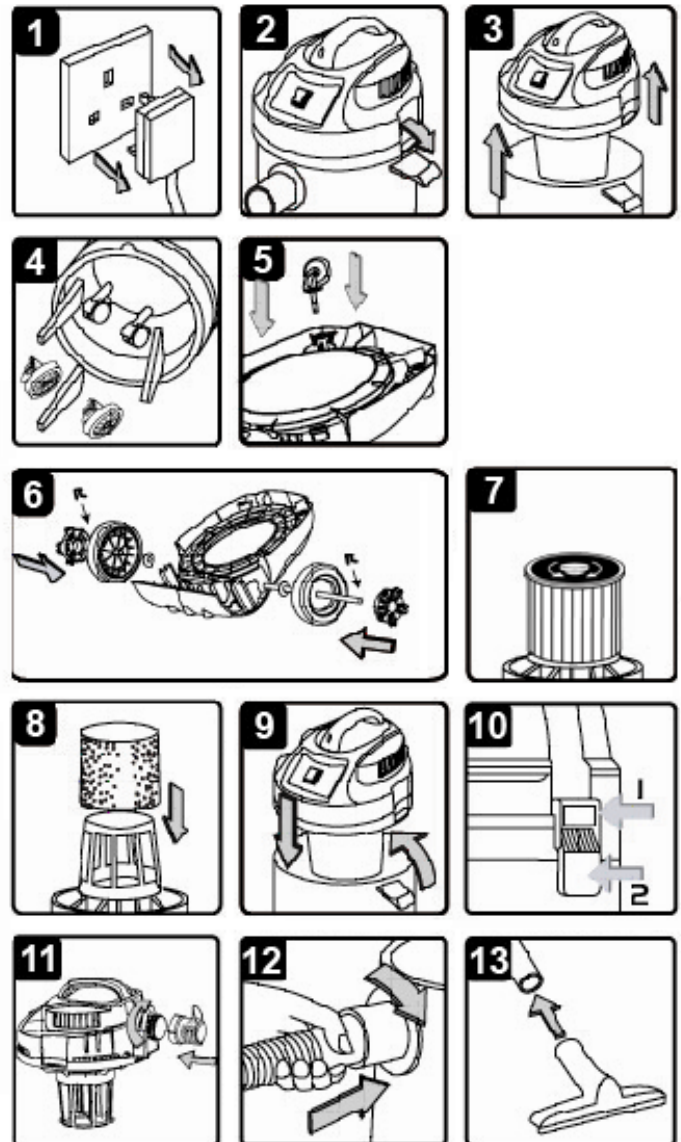
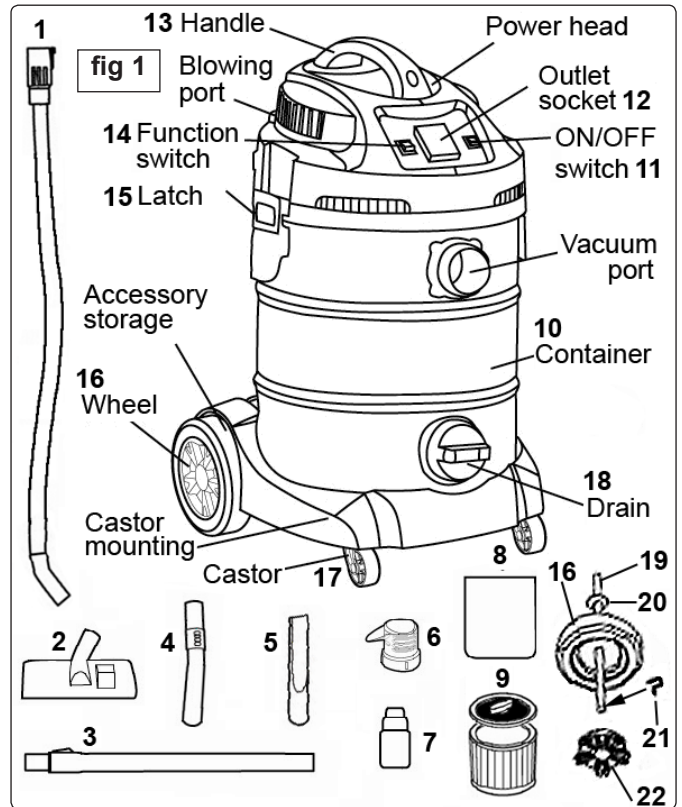

OPERATE VACUUM WITH TOOL

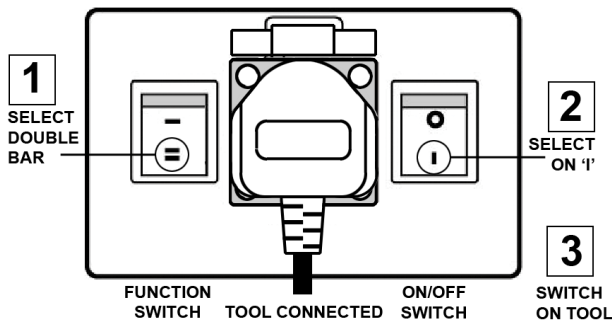

5.2 OPERATE VACUUM WITH DUST FREE TOOL

- 5.2.1 Select double bar position on function switch.
- 5.2.2 Move the ON/OFF switch to the ('I') position.
- 5.2.3 Vacuum cleaner starts when tool is switched on.

6. DRY VACUUM CLEANING

- WARNING!** Ensure you read, understand and apply Section 1 'Safety Instructions'.
Reminder: DO NOT vacuum hazardous substances. Use of an incorrect cartridge filter will invalidate your warranty.
- 6.1 Ensure the machine is unplugged from the power supply.
- 6.2 Remove the top section and with the raised rim uppermost fit the cartridge filter tube down over the filter basket and push fully home. Place the locking disc onto the top of the filter and turn the locking bar until the latch drops into the slot in the top of the filter cage. Continue turning until the filter is fully locked down. (see below)
- 6.3 Reposition the head onto the drum body and clip in place.
- 6.4 Insert the larger end of the flexible hose into the front inlet on the container and lock in place. Push the required attachment onto the free end of the hose.
- 6.5 Plug in the power supply.
- 6.6 Switch to the 'On' (position 'I').
- 6.7 When you have completed vacuuming, press the switch to 'Off' (position 'O') and unplug from power supply. Regularly check the container and dispose of dust and debris when it is 1/2 full.

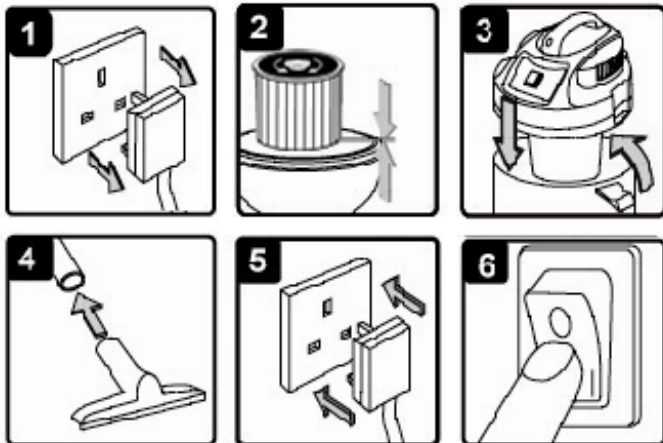

7. WET VACUUM CLEANING

- WARNING!** Ensure you read, understand and apply Section 1. 'Safety Instructions'. **Reminder: Remove plug from power supply before opening unit. DO NOT vacuum solvents, explosives, inflammable and/or hazardous liquids such as petrol, oil, spirits, paint, thinners, acids etc.**
- WARNING! Not designed for liquid storage. Always empty liquids after use and before storing.**
- 7.1 Ensure the machine is unplugged from the power supply. Make sure the tank is clean and free from dust and dirt.
- 7.2 Remove the cartridge filter and fit a foam filter over the filter basket. Replace the top section onto the container.

- 7.3 To the same flexible hose as used in dry cleaning fit the desired nozzle.
- 7.4 Ensure the switch is 'Off' (position 'O') before plugging into the power supply.
- 7.5 Press the switch to 'On' (position 'I').
Note: To vacuum large quantities of liquid, from a sink or tank etc, do not immerse the nozzle completely in the liquid, leave a gap at the top of the nozzle opening to allow an air inflow. The machine is fitted with a float valve which stops the suction action when the tank has reached its maximum capacity. The user will notice an increase in motor speed. When this happens, turn off the machine, disconnect from power supply and empty the container either by removing the power head and pouring the liquid out or by removing the drain cap at the base of the container. After wet vacuuming, turn the machine off and unplug from power supply. Empty the container and clean and dry the inside and outside before storage. Remember! After wet vacuuming the foam filter must be removed and a cartridge filter must be fitted before dry vacuuming again.

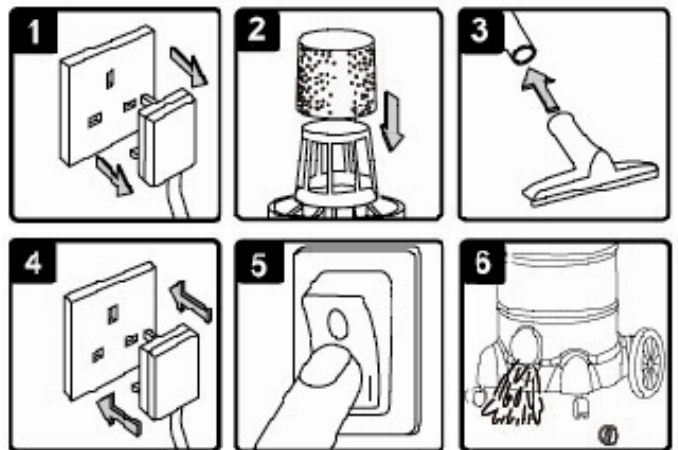

8. BLOWING

- WARNING!** Wear a dust mask.
- WARNING!** Always wear safety goggles when using the unit for blowing.
- WARNING!** Keep bystanders clear from blowing debris. Make sure the container is empty before using the unit as a blower.
- 8.1 Remove the hose from the vacuum port and insert the large end of the hose into the blowing port on the other side of the power head and twist to the right to lock it in place.
- 8.2 Fit the desired extension tube/nozzle to the free end of the vacuum hose.
- 8.3 Ensure the ON/OFF switch is in the OFF position.
- 8.4 Plug the unit into the mains power supply.
- 8.5 Take firm hold of the loose end of the hose and move the ON/OFF switch to the ON 'I' to start the motor.
- 8.6 If the unit does not appear to be blowing, switch OFF and check for blockages in the hosepipe.



9. USING DUST FREE TOOLS

- 9.1 Connect the tool to the vacuum hose using the rubber adaptor supplied. Ensure that the ON/OFF switch is in the **OFF** position then plug the dust free tool into the covered socket provided on the front of the power head (see fig.1-12). Move the function switch to the double bar position. Move the ON/OFF switch to the ON ('I') position. The vacuum cleaner will start automatically when the tool is switched on. When the tool is switched off the vacuum will continue to run for 10 seconds to ensure that the tool and hose are left free of dust.

10. MAINTENANCE



10.1 GENERAL MAINTENANCE.

- 10.1.1 Ensure the machine is unplugged from the power supply. (1)
 10.1.2 Disconnect the hose from the container. (2)
 10.1.3 Undo the clasps and remove motor head from the container. (3)
 10.1.4 Clear out any dirt or debris from the container and hose. (4)
 10.1.5 Check that the telescopic suction tube operates smoothly, and check the power cable to make sure it has not been damaged.

10.2. CARE OF CARTRIDGE FILTER

IMPORTANT! Clean or change the cartridge filter regularly for best performance and long product life. The cartridge filter is essential for the proper functioning of the cleaner. **If the machine is used without a cartridge filter the motor will burn out and the warranty will be voided.** Always keep a new, spare filter on hand.

- 10.2.1 The cartridge filters supplied are made of a high quality material designed to trap small dust particles and should only be used for dry vacuum cleaning. **If the cartridge filter becomes wet it will clog very quickly and be very difficult to clean.** Always handle filters very carefully when removing and cleaning them. Check the filter for tears or small holes. Replace the filter if it is found to be damaged.

10.3 INSTALLING CARTRIDGE FILTER (DRY VACUUM ONLY)

- 10.3.1 Remove the top section and with the raised rim uppermost fit the cartridge filter tube down over the filter basket and push fully home. Place the locking disc onto the top of the filter and turn the locking bar until the latch drops into the slot in the top of the filter cage. Continue turning until the filter is fully locked down. (see below)

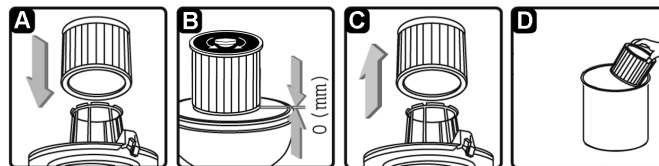

10.4 CLEANING CARTRIDGE FILTER

- 10.4.1 To remove the cartridge filter pull it carefully upwards and off the filter cage. (C)
 10.4.2 Clean the cartridge by gently tapping it over a waste receptacle or lightly brushing with a soft brush. Do this outdoors. (D)
 10.4.3 If a cartridge filter becomes inadvertently wetted it should be removed and allowed to air dry for 24 hours before reinstalling.

10.5 FITTING A FOAM SLEEVE FILTER (WET VACUUM ONLY)

- 10.5.1 Remove the power head and turn it upside down. Carefully remove the cartridge filter and store safely for future use.
 10.5.2 Slide the foam sleeve filter down over the filter cage ensuring that the whole cage is covered. See 1 & 2
 10.5.3 Invert the power head and refit it onto the container

10.6 CLEANING A FOAM SLEEVE FILTER

- 10.6.1 Carefully remove the foam sleeve from the filter cage.(3)
 10.6.2 Wash the foam sleeve in a mild soap and water solution and then rinse it in clean water. (4)
 10.6.3 Allow the filter to air dry before installing and using again.

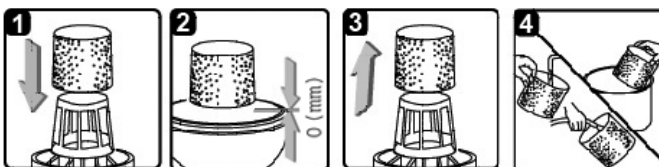

11. TROUBLESHOOTING

Symptom	Possible causes	Solutions
Vacuum will not operate	No power supply	Check power supply - cable, breakers, fuses.
	Faulty power cable	Unplug and check the power cable. If damaged have it replaced by your local Sealey dealer.
	Container full	Empty container
Dust expelled from the motor cover	Cartridge filter missing or damaged	Fit cartridge filter or replace damaged filter
Reduced efficiency and increased motor/speed vibration	There is a blockage in the nozzle or hose or in the container inlet. Cartridge filter blocked by fine dust.	Check nozzle, hose and container inlets and clear any blockages found. Remove filter and clean it or install new filter.

12. CONSUMABLES

MODEL.....PC300SDAUTO.V3
 Locking Cartridge Filter (Must be used for dry vacuuming).....Part No. PC200CFL
 Foam FilterPart No. PC200FF10
 Dust Bags (Optional)Part No. PC300PB5

IMPORTANT! IF THE MACHINE IS USED WITHOUT A CARTRIDGE FILTER FITTED THE MOTOR WILL BURN OUT EVENTUALLY AND YOUR GUARANTEE WILL BE INVALIDATED. ALWAYS KEEP A SPARE CARTRIDGE FILTER HANDY.

Environmental Protection



Recycle unwanted materials instead of disposing of them as waste. All tools, accessories and packaging should be sorted, taken to a recycling centre and disposed of in a manner which is compatible with the environment. When the product becomes completely unserviceable and requires disposal, drain off any fluids (if applicable) into approved containers and dispose of the product and the fluids according to local regulations.

NOTE: It is our policy to improve products continually and as such we reserve the right to alter data, specifications and component parts without prior notice.

IMPORTANT: No liability is accepted for incorrect use of this product.

WARRANTY: Guarantee is 12 months from purchase date, proof of which will be required for any claim.



Sole UK Distributor, Sealey Group,
Kempson Way, Suffolk Business Park,
Bury St. Edmunds, Suffolk,
IP32 7AR



01284 757500



01284 703534



www.sealey.co.uk



sales@sealey.co.uk