

Thank you for purchasing a Sealey product. Manufactured to a high standard this product will, if used according to these instructions and properly maintained, give you years of trouble free performance.

IMPORTANT: PLEASE READ THESE INSTRUCTIONS CAREFULLY. NOTE THE SAFE OPERATIONAL REQUIREMENTS, WARNINGS & CAUTIONS. USE THE PRODUCT CORRECTLY AND WITH CARE FOR THE PURPOSE FOR WHICH IT IS INTENDED. FAILURE TO DO SO MAY CAUSE DAMAGE AND/OR PERSONAL INJURY AND WILL INVALIDATE THE WARRANTY. PLEASE KEEP INSTRUCTIONS SAFE FOR FUTURE USE.

1. SAFETY INSTRUCTIONS

1.1. ELECTRICAL SAFETY

WARNING! It is the responsibility of the owner and the operator to read, understand and comply with the following: You must check all electrical products, before use, to ensure that they are safe. You must inspect power cables, plugs, sockets and any other connectors for wear or damage. You must ensure that the risk of electric shock is minimised by the installation of appropriate safety devices. A Residual Current Circuit Breaker (RCCB) should be incorporated in the main distribution board. We also recommend that a Residual Current Device (RCD) is used. It is particularly important to use an RCD with portable products that are plugged into a supply which is not protected by an RCCB. If in any doubt consult a qualified electrician. You may obtain a Residual Current Device by contacting your Sealey dealer.

You must also read and understand the following instructions concerning electrical safety.

1.1.1 The **Electricity at Work Act 1989** requires all portable electrical appliances, if used on business premises, to be tested by a qualified electrician, using a Portable Appliance Tester (PAT), at least once a year.

1.1.2 The **Health & Safety at Work Act 1974** makes owners of electrical appliances responsible for the safe condition of those appliances and the safety of the appliance operators. **If in any doubt about electrical safety, contact a qualified electrician.**

1.1.3 Ensure that the insulation on all cables and on the appliance is safe before connecting it to the power supply. See 1.1.1. and 1.1.2. and use a Portable Appliance Tester.

1.1.4 Ensure that cables are always protected against short circuit and overload.

1.1.5 Regularly inspect power supply cables and plugs for wear or damage and check all connections to ensure that none is loose.

1.1.6 **Important:** Ensure that the voltage marked on the appliance matches the power supply to be used and that the plug is fitted with the correct fuse - see fuse rating at right.

1.1.7 **DO NOT** pull or carry the appliance by the power cable.

1.1.8 **DO NOT** pull the plug from the socket by the cable.

1.1.9 **DO NOT** use worn or damaged cables, plugs or connectors. Immediately have any faulty item repaired or replaced by a qualified electrician. When an ASTA/BS approved UK 3 pin plug is damaged, cut the cable just above the plug and **dispose of the plug safely.** Fit a new plug according to the following instructions (UK only).

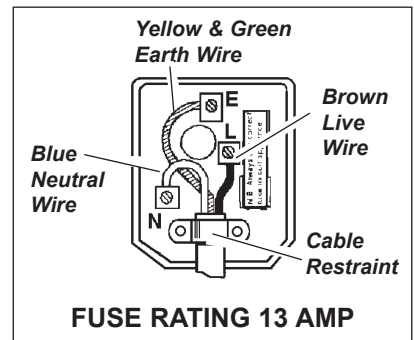

a) Connect the **GREEN/YELLOW earth wire to the earth terminal 'E'.**

b) Connect the **BROWN live wire to the live terminal 'L'.**

c) Connect the **BLUE neutral wire to the neutral terminal 'N'.**

d) **After wiring, check that there are no bare wires, that all wires have been correctly connected, that the cable outer insulation extends beyond the cable restraint and that the restraint is tight.**

Double insulated products, which are always marked with this symbol , are fitted with live (brown) and neutral (blue) wires only.

To rewire, connect the wires as indicated above - **DO NOT** connect either wire to the earth terminal.

1.1.10 Products which require more than 13 amps are supplied without a plug. In this case you must contact a qualified electrician to ensure that a suitably rated supply is available. We recommend that you discuss the installation of an industrial round pin plug and socket with your electrician.

1.1.11 If an extension reel is used it should be fully unwound before connection. A reel with an RCD fitted is preferred since any appliance plugged into it will be protected. The cable core section is important and should be at least 1.5mm², but to be absolutely sure that the capacity of the reel is suitable for this product and for others which may be used in the other output sockets, we recommend the use of 2.5mm² section cable. If extension reel is to be used outdoors, ensure it is marked for outdoor use.

1.2 GENERAL SAFETY

- WARNING!** *Water and Electricity are dangerous partners. Be extremely cautious and always be aware that this device uses an electric motor. Always plug into a RCD (see electrical safety above). Unplug from mains before changing accessories or servicing.*
- WARNING!** *DO NOT use the washer if any part of the unit, gun, nozzle, detergent bottle, hose or cables is damaged. Replace or repair using genuine parts only. Un-authorized parts may be dangerous and will invalidate your warranty. Always check connections are correctly secured and not cracked or damaged in any way before using the machine.*
- WARNING!** *Use washer on a flat, levelled surface, in a vertical position. Failure to do so will invalidate your warranty. NEVER lay the washer down during use.*
- ✓ Always be aware of the potential hazards that may occur during use. Study the applications and limitations of the washer before use.
- ✓ Keep the washer in good condition. Use an authorised agent to service the unit.
- ✓ Wear adequate protective clothing, goggles and anti-slip rubber soled footwear.
- ✓ Use where air can freely circulate around the washer to avoid the machine over-heating.
- WARNING!** *Ensure all persons and animals keep at a minimum distance of 16 yards (15mtr) from the washer when in use.*
- WARNING!** *The pressure washer must only be used with clean water. Non-filtered water or corrosive chemicals must not be used as they will damage the cleaner.*
- ✓ Ensure you comply with all local water supply regulations. Power washers may only be connected to mains drinking water supply if a valve to prevent back flow is installed in the supply hose, or at the tap outlet.
- ✓ Position the washer as near to the water supply as possible.
- ✓ The supply hose must be reinforced, and have an internal diameter of 1/2". The water supply must be at least equal to the cleaner capacity. The water temperature must **NOT** exceed 122°F (50°C). The water supply pressure must **NOT** exceed 145psi (10bar).
- ✓ Ensure the nozzle is aimed correctly at the working surface before activating the jet.
- ✓ Before operating the trigger, GRIP the gun firmly to counteract the recoil from the high pressure water jet.
- WARNING!** *Avoid sudden bursts of water as such will cause water pressure to drop and put extreme pressure on hoses and connectors.*
- ✓ If, during operation, power failure occurs turn the electricity and water off for safety reasons.
- WARNING!** *The high pressure jet will cause loose particles to be propelled at high speed, which may cause serious injury.*

- ❑ **WARNING! DO NOT use the washer on any material containing asbestos as this may release hazardous asbestos particles into the atmosphere.**
- ❑ **WARNING! DO NOT use the washer without a water supply. Dry running can seriously damage the unit.**
- ❑ **WARNING!** Discharge residual pressure before disconnecting the washer hose. Pressure left in unit may cause injury.
- ✓ After use disconnect washer from electrical and water supplies and store in a safe, dry, childproof area.
- x **DO NOT** obstruct ventilation grills during operation.
- x **DO NOT** touch plug with wet hands, to avoid the risk of electrocution. Keep all connections dry and off the ground.
- x **DO NOT** direct jet against yourself, other persons or animals, electrical equipment or the machine itself.
- x **DO NOT** use washer if you are tired or under the influence of alcohol, drugs or intoxicating medication.
- x **DO NOT** use the washer with flammable or toxic liquids or any other product. Only use recommended detergent. Non-recommended detergents may corrode the machine cover and accessories.
- x **DO NOT** jam the trigger in the operating position.
- x **DO NOT** adjust any internal control valves, as they have been set at the factory.
- x **DO NOT** leave the washer running unattended.
- x **DO NOT** connect other appliances to the machine inlet or outlet.
- x **DO NOT** use in damp or wet weather conditions.
- x **DO NOT** move the unit by pulling the hoses or electrical cables. Use handle.
- x **DO NOT** allow children or untrained persons to operate the washer.

2. INTRODUCTION

Heavy-duty induction motor unit with integral trolley. Pump unit fitted with high pressure by-pass to preserve pump life. Features automatic Total Stop System which switches the motor on and off when the lance trigger is operated, prolonging the motor life. Supplied with hose, trigger, spray lance and Rotablast Nozzle® which helps develop the same Effective Cleaning Power (ECP) as a 3200psi washer. Includes foam applicator for pre-wash. Suitable for a wide range of automotive, industrial, agricultural, marine and domestic applications.

3. CONTENTS & SPECIFICATION

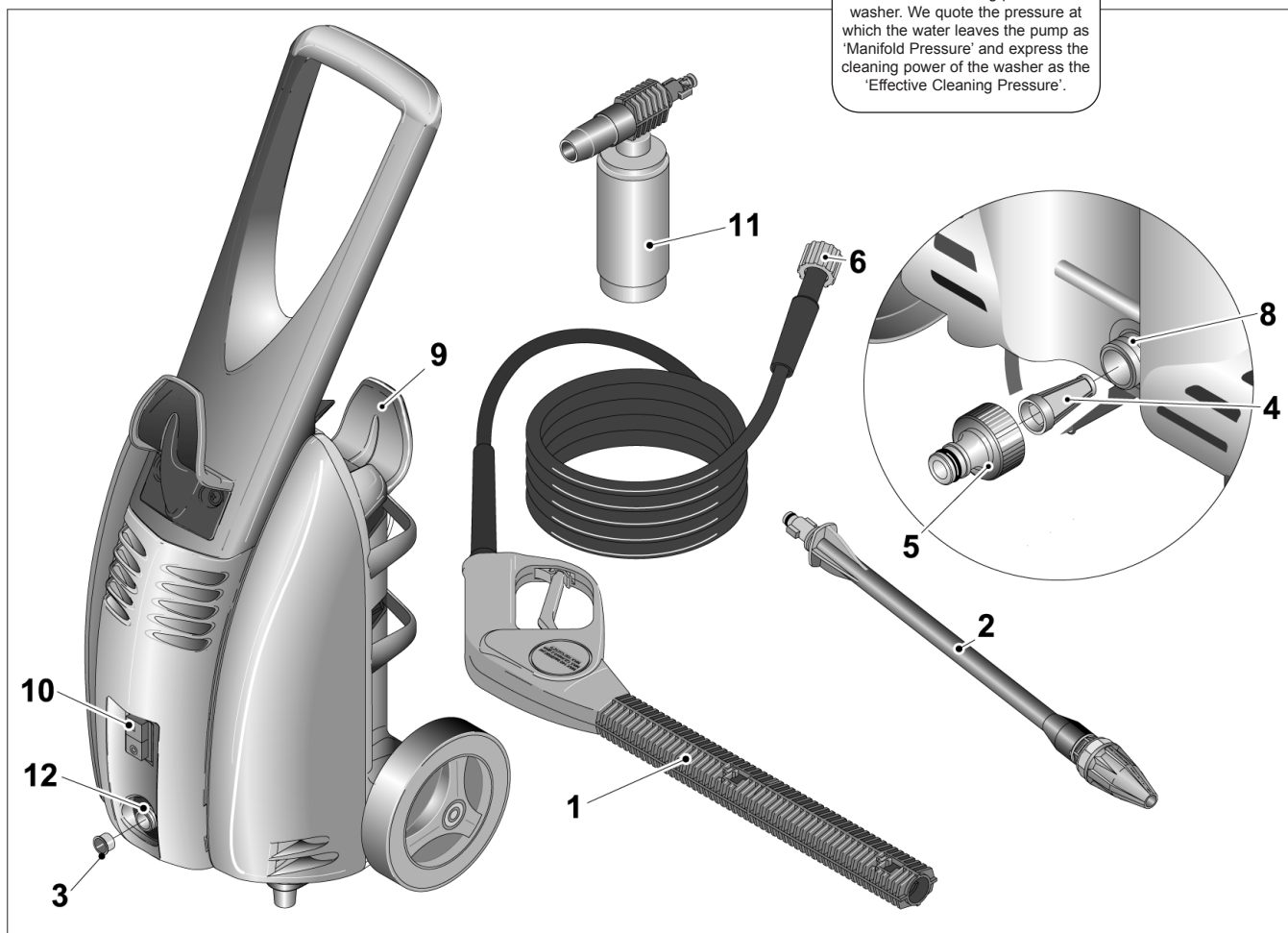

By rotating the stream of water at high speed, it is possible to increase the effective cleaning pressure of washer. We quote the pressure at which the water leaves the pump as 'Manifold Pressure' and express the cleaning power of the washer as the 'Effective Cleaning Pressure'.

3.1. CONTENTS

Unpack the product and check contents against the list below. Also check that the machine has an identification plate or label. If label or parts are damaged or missing contact your supplier immediately.

- | | | | | | |
|---|---------------------------|---|------------------------------|----|----------------------|
| 1 | Gun and hose assembly | 5 | Supply hose quick connector | 10 | ON/OFF switch |
| 2 | Turbo nozzle with lance | 6 | High pressure hose connector | 11 | Detergent dispenser |
| 3 | Water plug | 8 | Water inlet | 12 | High pressure outlet |
| 4 | Water inlet filter screen | 9 | Cable tidy | | |

3.2. SPECIFICATION

Manifold Pressure	95bar	Motor Type	Induction	Total Stop	Yes
Max Pressure	130bar	Input:	230V - 7.8A	Hose Length	6mtr
Effective Cleaning Pressure	3200psi	Rec. Power Supply	13A	Rotorblast Nozzle	Yes
Water Flow	380ltr/h	Motor Speed	2800rpm	Integral trolley	Yes
Motor Power	1800W	Max. Inlet Temp	50°C	Weight	13kg

4. SET UP

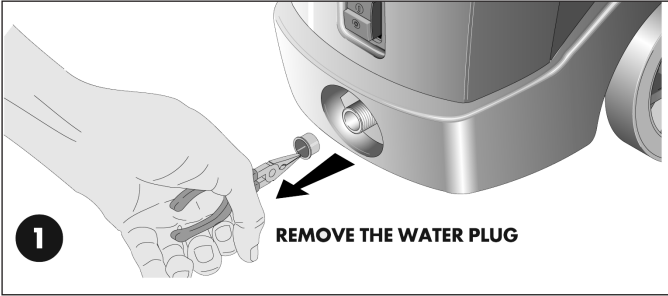

4.1 **Connecting the high pressure hose.** Remove and discard the transit plug from the water 'out' connector on the lower front of the machine (see fig.1). Attach the high pressure hose as indicated in fig.2 ensuring that the connector is tight.

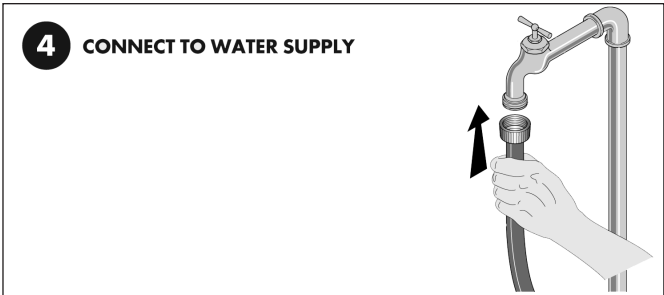
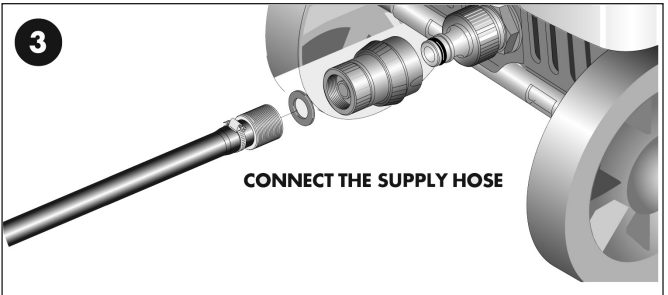
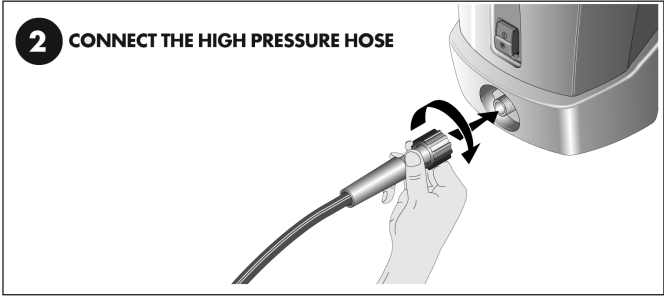

4.2 **Connecting the water supply.** Screw the hose connector to the water inlet on the machine (see fig.3). Use a reinforced hose pipe with an internal diameter of 1/2" and connect to the mains water supply as indicated in fig.4.

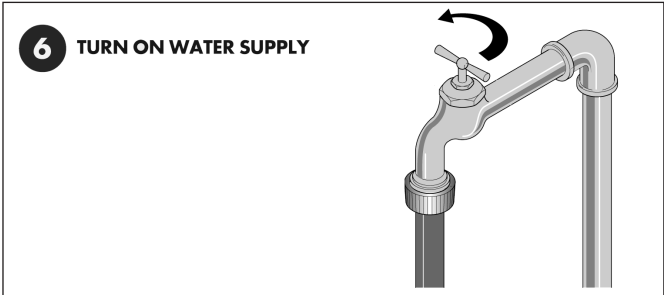
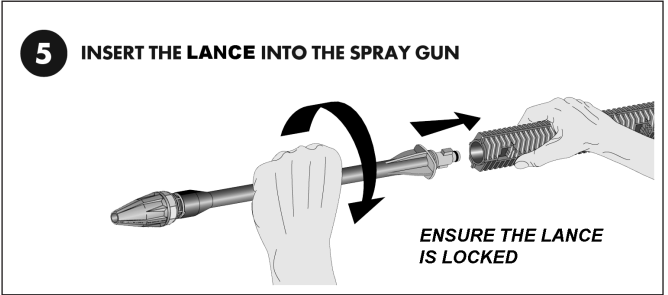

4.3 **Assembling the lance and nozzle.** Insert the lance into the gun as shown in fig.5. Twist the lance through 90° until it clicks into place. Turn on the water and check that all connections are water tight.

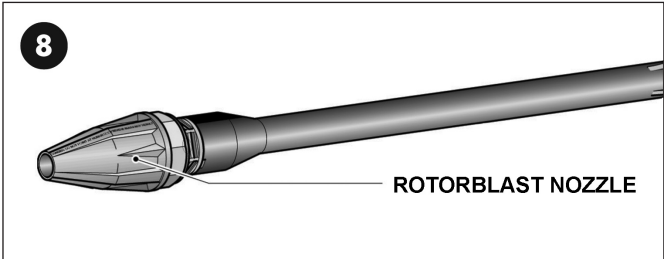
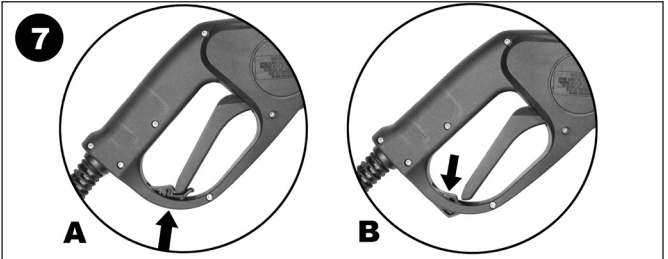

4.4 **Safety catch.** Familiarise yourself with the operation of the safety catch. See diagram above and section 5.1.

4.5 **Rotorblast nozzle.** The nozzle is non-adjustable. Do not attempt to turn it or disassemble it or your warranty may be void. Keep the nozzle 150 to 200mm from the surface being cleaned.

5. OPERATION

- WARNING! Ensure you read, understand and apply Section 1 safety instructions.**
- WARNING! Dry running can seriously damage the unit.**
- WARNING! DO NOT leave washer switched on for more than 15 minutes without operating trigger.**

5.1 **Operation of safety catch.** To prevent inadvertant operation of the unit the safety catch should always be engaged when the gun is not in use. To engage the catch push it upwards over the end of the trigger as shown in fig.7A. To release the catch press it downwards and away from the trigger as indicated in fig.7B. **Important! The washer motor will stop as soon as the gun trigger is released and will restart when the trigger is squeezed. Always allow at least 5 seconds between releasing the trigger and restarting.**

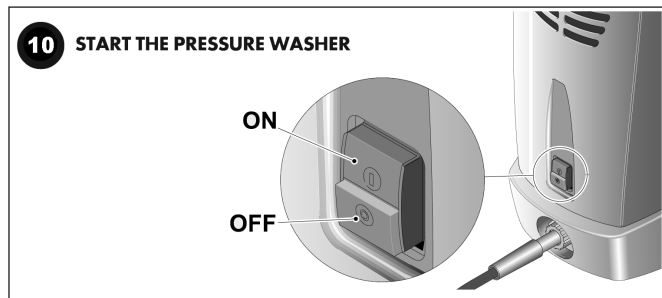
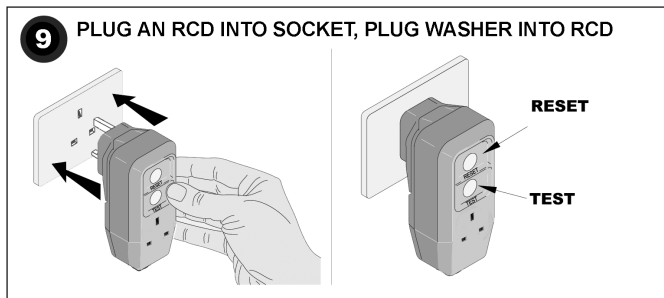

- 5.2 Primary checks.** Check that the inlet filter is clean; pump delivery and pressure will be reduced if blocked. Never use the machine without a filter (which is fitted inside the hose connector, see Item 4 in Section 3 'Contents'). Ensure that the water supply, high pressure hose and gun are correctly connected, and that air can freely circulate around the washer.
- 5.3 Connection to power supply.** The washer should be used in conjunction with an RCD safety cut-out device as indicated in fig.9. (An RCD can be purchased from your local Sealey dealer.) Plug the RCD into the mains supply and plug the washer into the RCD. Test the RCD in accordance with the RCD instructions.
- 5.4 Operating the machine.** Before switching on ensure that the lance is not directed at people, objects or animals prior to being directed at the object to be cleaned. It is recommended that the trigger is depressed before switching on the unit before every use. This reduces the back pressure and amperage draw which prevents fuses blowing. Switch the machine on by pressing the button marked 'I' as shown in fig.10 above. Release the safety catch (see fig.7B). Hold the spray gun firmly to counteract the recoil caused by the high pressure of the water. Point the lance at the object to be cleaned and fully depress the trigger. When the trigger is released the motor will automatically switch off.
- 5.5 Rotorblast nozzle.** The nozzle is non-adjustable. Do not attempt to turn it or disassemble it or your warranty may be void. Keep the nozzle 150 to 200mm from the surface being cleaned.
- 5.6 Using detergent.** Use only detergents approved for use in pressure washers.
- 5.6.1 Remove the lance that is attached to the gun and attach the soap dispenser as indicated in fig.11.
- 5.6.2 Remove the bottle and check that the tube is not blocked.
- 5.6.3 Fill the bottle with detergent suitable for use with a pressure washer and re-attach it. As you operate the trigger the detergent will be automatically mixed with the water and discharged through the nozzle.
- 5.6.1 Dirt is dissolved by applying detergent to the dry surface. On vertical surfaces, work from the bottom upwards.
- 5.6.2 Leave the detergent to act for 1 - 2 minutes, but **DO NOT** allow the surface to dry out.
- 5.6.3. Re-attach the lance and wash down the surface with clean water.
- 5.7. When washing is completed.**
- 5.7.1. Switch the power supply off by pressing the button marked 'O' as indicated in fig.10.
- 5.7.2 Turn off the water supply tap.
- 5.7.3 Discharge residual pressure by pressing the trigger until no more water comes out of the nozzle.
- 5.7.4. Engage the trigger safety catch and unplug the machine from the electrical mains power supply.
- 5.7.5 Wipe the machine clean and dry and store in a clean, safe, dry, childproof location.
- NOTE:** a) **DO NOT** leave motor switched on for more than 15 minutes without operating trigger.
- b) If the water pressure drops (i.e. someone else using the same water supply), the washer will not operate correctly. Immediately switch off the motor and wait until the pressure is restored.
- c) Should the motor stop and fail to restart, the built in thermal cut-out may have tripped. Check to ensure that the washer is connected correctly to electrical and water supplies (also see Section 7 Troubleshooting). Wait 5 minutes for the cut-out to reset and re-start the motor. If the motor continues to cut out contact your authorised service agent.

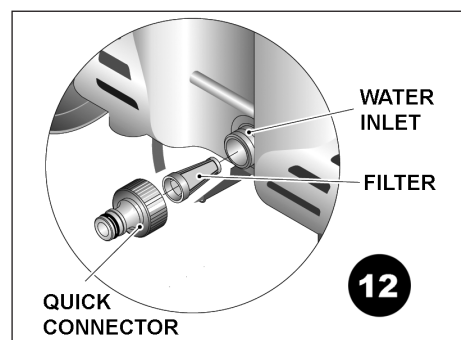
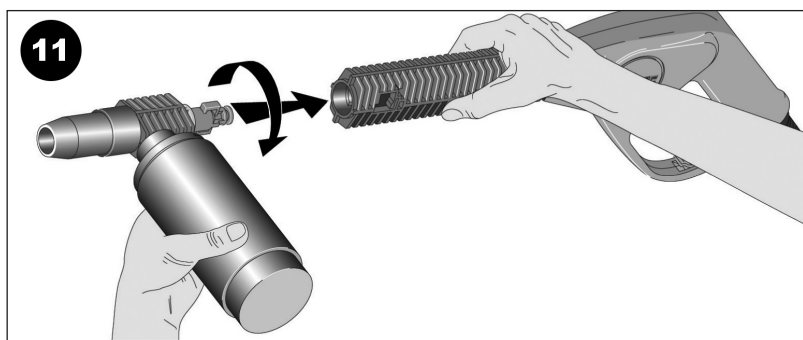

6. MAINTENANCE

- WARNING!** Ensure the pressure washer is switched off and unplugged from the electrical power supply and turned off at the water supply tap before proceeding.
- 6.1. Keep the washer clean at all times.
- 6.2. Regularly check washer, gun, lance, detergent bottle, hose, connections and cables for damage. Repair or replace any damaged items before next use. **DO NOT open the casing, use authorised agent to service the washer.**
- 6.3. Water Filter.**
- 6.3.1 The washer is equipped with a water inlet filter to protect the pump.
- 6.3.2 To clean the conical filter, remove the quick fit connection and the filter from the pump inlet as indicated in fig.12.
- 6.3.3 Backflush the filter to clean it.
- 6.3.4 Replace the screen and quick fit connector immediately to prevent any ingress of foreign matter into the pump.
- 6.4 Cooling system.**
- The air vents in and around the pressure washer must be kept clean and free of any obstructions to ensure proper air cooling of the motor during operation.

WARNING! Prevent water from penetrating the vents of the pressure washer to minimise the risk of damage to the machine and to reduce risk of shock to the operator.

6.5 Storage.

- 6.5.1 Store in a location where the washer will not be subject to freezing conditions.
- 6.5.2 Make sure that the pressure washer has been drained of water and remove the hoses.

7. TROUBLESHOOTING GUIDE

PROBLEM	CAUSE	REMEDY
Motor will not start or stops during operation.	Loose or disconnected plug. Tripped pressure washer thermal switch. Power blast trigger not operating properly.	Check plug connections / Reconnect plug Allow to cool and restart unit. Return to Service Agent
Circuit breaker trips or fuse blown in fuse box.	Circuit overload. Extension lead too long or wire size too small. Nozzle partially blocked causing excessive pressure.	Check that power supply is correctly rated. Disconnect other loads from circuit. Use proper lead as recommended in manual. Clean nozzle.
Water or oil leaking from bottom of pump.	A small amount of leakage is normal.	If leakage becomes excessive contact service agent.
Trigger will not move.	Safety catch engaged.	Release safety catch.
Unit will not stop when trigger is released.	Auto stop system inoperative.	Contact service agent.
Motor running but pump not reaching maximum pressure or has irregular pressure.	Water not turned on or partially on. Unit has been stored in freezing temperatures. Water inlet filter clogged. Kink in supply hose. Air in pump. Suction or discharge valves worn out.	Open water tap. Thaw out unit completely including hose, gun and lance. Clean filter. Straighten hose. Run washer with gun open and lance removed until a steady stream of water emerges. Contact Service Agent.

8. DECLARATION OF CONFORMITY

Declaration of Conformity We, the sole importer into the UK of Sealey Power Products, declare that the product listed below is in conformity with the following standards and directives.

Pressure Washer Model PC2950.V4

- 2004/108/EC EMC Directive
- 93/68/EEC CE Marking Directive
- 2006/95/EC Low Voltage Directive
- 2006/42/EC Machinery Directive



The construction file for this product is held by the Manufacturer and may be inspected, by a national authority, upon request to Jack Sealey Ltd.

Signed by Mark Sweetman  31th October 2008

For Jack Sealey Ltd. Sole importer into the UK of Sealey Power Products.

NOTE: It is our policy to continually improve products and as such we reserve the right to alter data, specifications and component parts without prior notice.

IMPORTANT: No responsibility is accepted for incorrect use of this equipment.

WARRANTY: Guarantee is 12 months from purchase, proof of which will be required for any claim.

INFORMATION: For a copy of our latest catalogue and promotions call us on 01284 757525 and leave your full name and address, including postcode.



Sole UK Distributor
Sealey Group,
Bury St. Edmunds, Suffolk.



01284 757500
01284 703534



www.sealey.co.uk
sales@sealey.co.uk