

Thank you for purchasing a Sealey product. Manufactured to a high standard this product will, if used according to these instructions and properly maintained, give you years of trouble free performance.



IMPORTANT: PLEASE READ THESE INSTRUCTIONS CAREFULLY. NOTE THE SAFE OPERATIONAL REQUIREMENTS, WARNINGS AND CAUTIONS. USE THE PRODUCT CORRECTLY AND WITH CARE FOR THE PURPOSE FOR WHICH IT IS INTENDED. FAILURE TO DO SO MAY CAUSE DAMAGE OR PERSONAL INJURY AND WILL INVALIDATE THE WARRANTY. PLEASE KEEP INSTRUCTIONS SAFE FOR FUTURE USE.

1. SAFETY INSTRUCTIONS

1.1. ELECTRICAL SAFETY. **WARNING! It is the user's responsibility to read, understand and comply with the following:**

You must check all electrical equipment and appliances to ensure they are safe before using. **You must** inspect power supply leads, plugs and all electrical connections for wear and damage. **You must** ensure the risk of electric shock is minimised by the installation of appropriate safety devices. An RCCB (Residual Current Circuit Breaker) should be incorporated in the main distribution board. We also recommend that an RCD (Residual Current Device) is used with all electrical products. It is particularly important to use an RCD with portable products that are plugged into an electrical supply not protected by an RCCB. If in doubt consult a qualified electrician. You may obtain a Residual Current Device by contacting your Sealey dealer. **You must** also read and understand the following instructions concerning electrical safety.

- 1.1.1. The **Electricity At Work Act 1989** requires all portable electrical appliances, if used on business premises, to be tested by a qualified electrician, using a Portable Appliance Tester (PAT), at least once a year.
- 1.1.2. The **Health & Safety at Work Act 1974** makes owners of electrical appliances responsible for the safe condition of the appliance and the safety of the appliance operator. **If in any doubt about electrical safety, contact a qualified electrician.**
- 1.1.3. Ensure the insulation on all cables and the product itself is safe before connecting to the mains power supply. See 1.1.1. & 1.1.2. above and use a Portable Appliance Tester (PAT).
- 1.1.4. Ensure that cables are always protected against short circuit and overload.
- 1.1.5. Regularly inspect power supply leads and plugs for wear and damage and all electrical connections to ensure that none is loose.
- 1.1.6. **Important:** Ensure the voltage marked on the product is the same as the electrical power supply to be used and check that plugs are fitted with the correct capacity fuse.
- 1.1.7. DO NOT pull or carry the powered appliance by its power supply lead.
- 1.1.8. DO NOT pull power plugs from sockets by the power cable.
- 1.1.9. DO NOT use worn or damage leads, plugs or connections. Immediately replace or have repaired by a qualified electrician.
- 1.1.10. **NOTE: THIS PRODUCT IS INTENDED FOR USE ON AN INDUSTRIAL 30 AMP SUPPLY WHICH MUST BE INSTALLED BY A QUALIFIED ELECTRICIAN.** It may be possible to operate the washer from a domestic 13 amp outlet under the following conditions:

The mains supply must conform to IEE Wiring Regulations and the spur used to run the washer must not include any socket which could be used for another appliance. The distance of the socket from the mains distribution board must not exceed 5 metres.

An extension lead must not be used.

- 1.1.11. **Note:** Under certain conditions your washer will draw more than 13 amps. Consequently we recommend a 30 amp supply and suggest that a direct round pin plug/socket is installed by a qualified electrician. In the event that you choose to use a domestic 13 amp supply and ever have to replace the non-rewireable 13 amp plug supplied we provide the plug wiring instructions as follows (UK only - see diagram at right):

Ensure the unit is correctly earthed via a three-pin plug.

a) Connect the GREEN/YELLOW earth wire to the earth terminal 'E'.

b) Connect the BROWN live wire to live terminal 'L'.

c) Connect the BLUE neutral wire to the neutral terminal 'N'.

d) Ensure the plug is fitted with a 13 amp fuse.

After wiring, check there are no bare wires, that all wires have been correctly connected, that the cable external insulation extends beyond the cable restraint and that the restraint is tight.

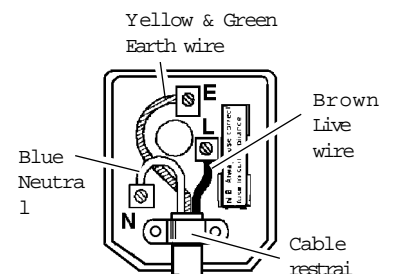

NOTE: IF USED ON A DOMESTIC 13 AMP SUPPLY AND THE FUSE REPEATEDLY BLOWS, CONTACT A QUALIFIED ELECTRICIAN TO INSTALL A 30 AMP SUPPLY.

1.2 GENERAL SAFETY

WARNING! Water and Electricity are dangerous partners. Be extremely cautious and always be aware that this device uses an electric motor. Always plug into an RCD (See electrical safety 1.1. above).

WARNING! Always use the washer on a flat, level surface, in a horizontal position. **Failure to do so will invalidate your warranty.**

WARNING! Do not operate the washer if damaged. Replace or repair using recommended parts only. **Non-authorized parts may be dangerous and will invalidate your warranty.**

Always be aware of the potential hazards that may occur during use.

Study the applications and limitations of the washer before use.

If during operation power failure occurs, turn the unit off and remove the plug for safety reasons.

Keep the washer in good condition. Regular maintenance will give the best and safest performance.

Wear adequate protective clothing, goggles and anti-slip rubber soled footwear.

Ensure the operating area is clear of other people and animals.

DO NOT connect other appliances to the same outlet.

DO NOT use in damp or wet weather conditions.

DO NOT attempt to move the cleaner by pulling on the high pressure hose; use the handle provided.

DO NOT touch plug with wet hands. To avoid the risk of electrocution keep all connections dry and off the ground.

DO NOT direct jet against yourself, other persons or animals, electrical equipment or the machine itself.

DO NOT use the washer if you are tired, under the influence of alcohol, drugs or intoxicating medication.

DO NOT allow children or untrained persons to operate the washer.

Keep children and unauthorised persons away from the working area.

When not in use unplug from the mains power supply and store in a safe dry, childproof area.

2. TECHNICAL SPECIFICATIONS

	PC2275	PC2285
Manifold Pressure	1750 psi	1850 psi
Effective Cleaning Power	1750 psi	1850 psi
Water Flow	480 l/h	600 l/h
Motor Power	2180 W	2285 W
Input Voltage	230 V	230 V
Motor rpm	2800	2800
Max Inlet Temp	60°C	60°C
Trolley Included	Yes	Yes
Hose Length	7.4 m	7.4 m
Weight	28 kg	31 kg



3. SETUP & ASSEMBLY

WARNING! Ensure the washer is not connected to the mains power before continuing; or when changing any accessories, performing any maintenance, or servicing. The water supply hose should be reinforced and have an internal diameter of 13mm (1/2"). The minimum water supply rate should be 500 l/h for PC2275, and 620 l/h for PC2285.

3.1. Preliminary checks and advice

- 3.1.1. Before starting ensure the water intake is correctly connected. Dry running can seriously damage the unit.
- 3.1.2. Check the inlet filter is clean; pump delivery and pressure will be reduced if blocked. Never use the machine without a filter (fig 1).
- 3.1.3. The unit is filled with oil and sealed at the factory. There is no need to check the oil level.

3.2. Setup

- 3.2.1. Insert the lance into the trigger assembly and twist to secure (fig 2).
- 3.2.2. Connect the trigger assembly to the high pressure hose and tighten with a 17mm spanner (fig 3).
- 3.2.3. Connect the high pressure hose to the top water outlet on the washer (fig 4).
- 3.2.4. Connect the water supply hose to the bottom water inlet on the washer (fig 4).
- 3.2.5. Assemble the handle as follows referring to (fig 5):
 - a) Place pipes D into handle grip A (Each grip has one locating plug which must pass through the locating hole in the pipe).
 - b) Fit grip B and secure with the 8 nuts and bolts provided (C).
 - c) Fit cones F and lock rings E over the pipes. Insert the pipes in the tank-frame G, and tighten the lock rings.

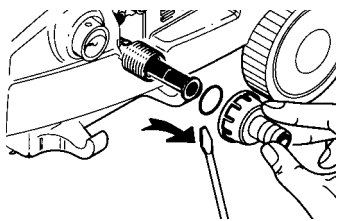

fig 1

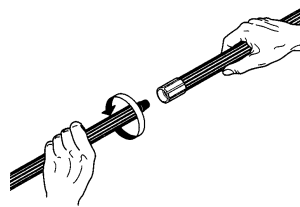

fig 2

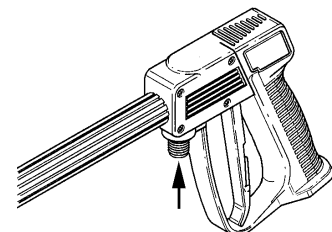

fig 3

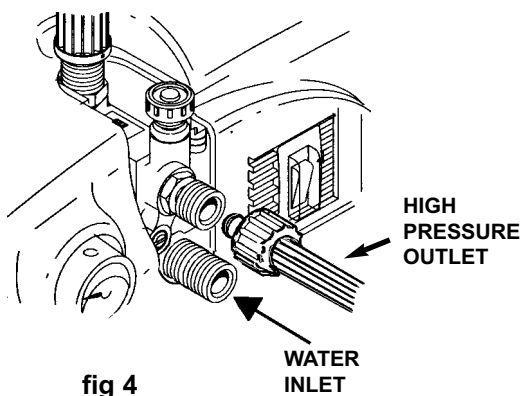

fig 4

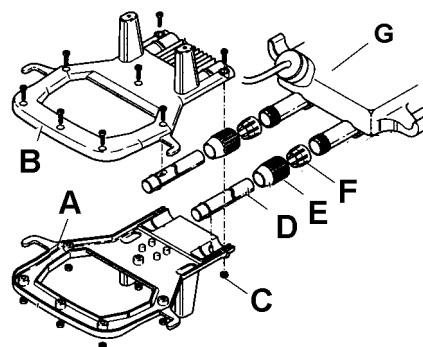

fig 5

4. OPERATION

IMPORTANT! The motors in these washers are 230V/2.18kW (PC2275) and 230V/2.29kW (PC2285) and at normal mains voltage will start within the capacity of a 13 amp fused circuit. Certain local conditions relating to electrical supply in the UK can result in the voltage varying between a low of 216 volts and a high of 253 volts. At such times of fluctuating voltage the 13 amp fuse in the washer plug may blow. This is normal and is not a fault with the washer. However if it happens regularly we recommend that you consult an electrician with a view to installing a 30 amp supply, with contact breaker, to avoid the inconvenience of frequent fuse replacement. Extension leads **MUST NOT** be used to connect the washer to a 13 amp supply as the resulting voltage drop will cause the 13 amp fuse to blow.

WARNING! Ensure you have read, understood and apply Section 1 safety instructions.
WARNING! Dry running can seriously damage the unit.
WARNING! DO NOT leave motor running for more than 1-2 minutes without operating the trigger, as temperature/pressure increase may damage sealing system.

WARNING! While the machine is running, DO NOT cover it or place in an enclosed space with poor ventilation. The water temperature should NOT exceed 60°C (140°F). The water pressure must NOT exceed 10 bar (145 psi)

NOTE: For instructional purposes the terms used to explain the trigger functions are :
 a) trigger depressed = open. b) trigger released = closed.

4.1. Precautions before starting

If the washer has not been used for a prolonged period, turning the machine on may damage the motor. To avoid this, ensure the washer is unplugged from the mains power supply and then turn the motor shaft by inserting the allen key (provided) through the fan cowling located at the bottom end of the washer. This will release any blockages, deposits or lime scale. **Remove the key** before plugging the washer into the mains power supply and switching on.

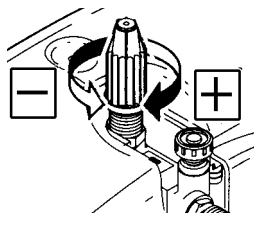

fig 6

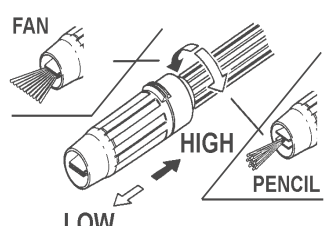

fig 7

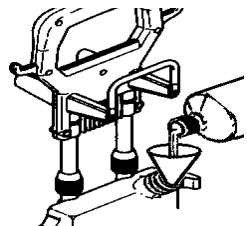

fig 8

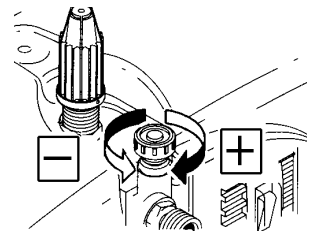

fig 9

4.2. Start procedure

- 4.2.1. Fully open mains water tap, ensure there are no leaks from any of the hoses or connectors and that all hoses are straight.
- 4.2.2. Depress the trigger to allow any air to escape, hold for 30 seconds.
- 4.2.3. While holding the trigger open turn the machine on, and adjust the motor control setting knob to the desired speed setting (fig 6).

4.3. Adjustments

WARNING! Avoid sudden bursts of water as they will cause the water pressure to drop and put extreme pressure on the hoses and connectors. If this happens you will need to switch the machine off, and refer back to the start procedure.

NOTE: Always depress the trigger and hold before starting the machine.

- 4.3.1. The water nozzle must only be adjusted with the trigger closed.
- 4.3.2. Rotate the nozzle to make the adjustment of the water jet between pencil or fan setting (fig 7).
- 4.3.3. Push the nozzle forwards for low pressure operation (suction and spraying of detergent), for high pressure operation (high pressure washing and rinsing) pull backwards (fig 7).
- 4.3.4. The water pressure will drop if someone else is using water from the same supply as the washer, If this happens switch off the motor immediately and wait until the pressure is restored.
- 4.3.5. When you have finished working, discharge residual pressure by depressing the trigger until no more water comes out of the nozzle.

4.4. Detergent use

WARNING! Liquid detergent can only be sprayed at low pressure.

- 4.4.1. Pour detergent into the opening at the top of the detergent tank located underneath the handle assembly (fig 8).
- 4.4.2. Adjust the nozzle to **low** pressure with a fan setting (fig 7).
- 4.4.3. The detergent strength can be adjusted by turning the detergent control knob (fig 9).

4.5. Pressure Gauge

The pressure gauge is liquid filled and indicates the output pressure in both psi and bar . Readings are only shown when **HIGH PRESSURE** is used, the trigger is depressed and water is flowing through the system. Familiarise yourself with the individual specifications shown in Section 2 and regularly check the gauge during use. Adjusting the motor speed (fig 6) will cause the gauge to rise or fall accordingly.

4.6. Recommended cleaning procedure

WARNING! The high pressure jet should be used with extreme caution. Ensure you aim the lance correctly at the work surface. Failure to do so may scatter loose particles at the same speed as the water jet, resulting in possible damage or personal injury. ALWAYS wear safety goggles and protective clothing.

- 4.6.1. Apply detergent at low pressure to a dry surface. On vertical surfaces, work from the bottom upwards. Leave the detergent to act for 1-2 minutes (DO NOT allow to dry out).
- 4.6.2. To rinse, adjust the water jet to high pressure (this will automatically shut the detergent off). Ensure the nozzle is at least 30 cm (10") from the surface. Avoid allowing the water to run onto unwashed surfaces.

4.7. Precautions for storing

WARNING! To avoid damage to the pump protect the washer against freezing.

NOTE: If the washer is to be stored for prolonged periods and there is a danger of freezing you must:-

- a) Mix a non-corrosive/non-toxic anti-freeze solution suitable for the expected temperature drop.
 - b) Disconnect the water supply hose and add the solution in 1/2 litre intervals via the water inlet with the motor running and the trigger depressed until the solution emerges from the lance.
- 4.7.1. Switch off the cleaner.
 - 4.7.2. Close the water supply tap.
 - 4.7.3. Discharge residual pressure by pressing the trigger until no more water comes out of the nozzle.
 - 4.7.4. Engage the gun safety catch.
 - 4.7.5. Thoroughly clean the water nozzle with the tool supplied (fig 10).
 - 4.7.6. Disconnect the plug from the mains power supply.

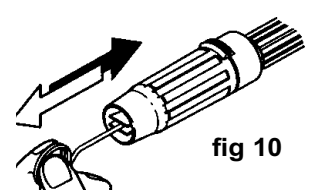

fig 10

5. TROUBLESHOOTING GUIDE

SYMPTOM	REASONS	REMEDY
Pump does not reach required pressure	Nozzle incorrect or worn Air being sucked into the system Valves dirty worn or stuck Dirty filter Regulator valve seat is worn Worn piston packing Unloader valve packing worn Low water supply pressure Air in pump	Replace the nozzle. Check that hoses and fittings are air tight. Clean or replace valve. Clean or replace Replace the valve seat. Check and replace Check and replace Open the water supply tap fully. Switch off the washer and operate the gun until a steady flow of water is obtained. Then switch washer back on.
Pressure drops during use	Valves dirty or worn Nozzle clogged or worn Unloader valve packing worn Worn piston packing Dirty filter Water temperature too high	Clean or replace valve. Clean with tool provided or replace the nozzle. Check and replace. Check and replace. Clean or replace Reduce temperature.
Pump noisy	Pump sucking air Valves dirty or worn Worn bearings Water temperature too high Dirty filter Water supply has been turned off	Check that hoses and fittings are air tight. Clean or replace valve. Check and replace if necessary. Reduce temperature. Clean or replace. Ensure water tap is fully on.
Presence of water in oil	High humidity in air Piston packing and oil seal worn	Increase frequency of servicing Check and replace.
Oil leaks	Oil seals worn	Check and replace.
Motor does not start when switched on	Plug is not connected	Check plug connections and that mains power supply is present.
Motor hums but does not start when switched on	Unsuitable mains voltage Pump is stuck Pump is frozen	Check for adequate power supply and cable condition. Check by turning motor manually with allen key in motor shaft. If jammed return to your Sealey dealer. Leave unit to thaw naturally. The pressure washer should be stored away from the threat of freezing. Extensive pump damage could otherwise occur.
Water dripping from pump	Piston packings worn Piston O-rings worn	Check and replace Check and replace
The motor stops	Tripped thermal cut-out due to overheating	Check that the mains voltage matches the specifications Switch off the motor and allow to cool for 5 minutes.

Declaration of Conformity We, the sole importer into the UK, declare that the products listed below are in conformity with the following standards and directives.

Pressure Washers PC2275 & PC2285

73/23/EEC Low Voltage Directive
89/336/EEC EMC Directive
98/37/EC Machinery Directive
93/68/EEC CE Marking Directive



The construction files for these products are held by the Manufacturer and may be inspected on request by contacting Jack Sealey Ltd.

Signed by Mark Sweetman

Date 1st June 1999

For Jack Sealey Ltd. Sole importer into the UK of Sealey Power Products.

NOTE: It is our policy to continually improve products and as such we reserve the right to alter data, specifications and component parts without prior notice.

IMPORTANT: No responsibility is accepted for incorrect use of this equipment

WARRANTY: Guarantee is 12 months from purchase, proof of which will be required for any claim.

INFORMATION: For a copy of our latest catalogue call us on 01284 757525 and leave your full name and address, including postcode.



Sole UK Distributor,
Sealey Group,
Bury St. Edmunds, Suffolk.



01284 757500



01284 703534

E-mail: sales@sealey.co.uk