



INSTRUCTIONS FOR:

WET & DRY VACUUM CLEANERS

Models: **PC220, PC230 & PC250**

Thank you for purchasing a Sealey product. Manufactured to a high standard this product will, if used according to these instructions and properly maintained, give you years of trouble free performance.

IMPORTANT: PLEASE READ THESE INSTRUCTIONS CAREFULLY. NOTE THE SAFE OPERATIONAL REQUIREMENTS, WARNINGS AND CAUTIONS. USE THE PRODUCT CORRECTLY AND WITH CARE FOR THE PURPOSE FOR WHICH IT IS INTENDED. FAILURE TO DO SO MAY CAUSE DAMAGE AND/OR PERSONAL INJURY AND WILL INVALIDATE THE WARRANTY. PLEASE KEEP INSTRUCTIONS SAFE FOR FUTURE USE.

1. SAFETY INSTRUCTIONS

1.1. ELECTRICAL SAFETY

WARNING! It is the responsibility of the owner and the operator to read, understand and comply with the following: You must check all electrical products, before use, to ensure that they are safe. You must inspect power cables, plugs, sockets and any other connectors for wear or damage. You must ensure that the risk of electric shock is minimised by the installation of appropriate safety devices. A Residual Current Circuit Breaker (RCCB) should be incorporated in the main distribution board. We also recommend that a Residual Current Device (RCD) is used. It is particularly important to use an RCD with portable products that are plugged into a supply which is not protected by an RCCB. If in any doubt consult a qualified electrician. You may obtain a Residual Current Device by contacting your Sealey dealer. **You must** also read and understand the following instructions concerning electrical safety.

- 1.1.1. The **Electricity at Work Act 1989** requires all portable electrical appliances, if used on business premises, to be tested by a qualified electrician, using a Portable Appliance Tester (PAT), at least once a year.
- 1.1.2. The **Health & Safety at Work Act 1974** makes owners of electrical appliances responsible for the safe condition of those appliances and the safety of the appliance operators. **If in any doubt about electrical safety, contact a qualified electrician.**
- 1.1.3. Ensure that the insulation on all cables and on the appliance is safe before connecting it to the power supply. See 1.1.1. and 1.1.2. and use a Portable Appliance Tester.
- 1.1.4. Ensure that cables are always protected against short circuit and overload.
- 1.1.5. Regularly inspect power supply cables and plugs for wear or damage and check all connections to ensure that none is loose.
- 1.1.6. **Important:** Ensure that the voltage marked on the appliance matches the power supply to be used and that the plug is fitted with the correct fuse - see fuse rating at right.
- 1.1.7. **DO NOT** pull or carry the appliance by the power cable.
- 1.1.8. **DO NOT** pull the plug from the socket by the cable.
- 1.1.9. **DO NOT** use worn or damaged cables, plugs or connectors. Immediately have any faulty item repaired or replaced by a qualified electrician. When an ASTA/BS approved UK 3 pin plug is damaged, cut the cable just above the plug and **dispose of the plug safely.** Fit a new plug according to the following instructions (UK only).

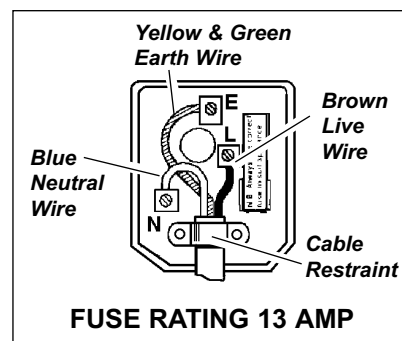

- a) **Connect the GREEN/YELLOW earth wire to the earth terminal 'E'.**
- b) **Connect the BROWN live wire to the live terminal 'L'.**
- c) **Connect the BLUE neutral wire to the neutral terminal 'N'.**
- d) **After wiring, check that there are no bare wires, that all wires have been correctly connected, that the cable outer insulation extends beyond the cable restraint and that the restraint is tight.**

Double insulated products, which are always marked with this symbol , are fitted with live (brown) and neutral (blue) wires only. To rewire, connect the wires as indicated above - **DO NOT** connect either wire to the earth terminal.

- 1.1.10. Products which require more than 13 amps are supplied without a plug. In this case you must contact a qualified electrician to ensure that a suitably rated supply is available. We recommend that you discuss the installation of an industrial round pin plug and socket with your electrician.
- 1.1.11. If an extension reel is used it should be fully unwound before connection. A reel with an RCD fitted is preferred since any appliance plugged into it will be protected. The cable core section is important and should be at least 1.5mm², but to be absolutely sure that the capacity of the reel is suitable for this product and for others which may be used in the other output sockets, we recommend the use of 2.5mm² section cable. If extension reel is to be used outdoors, ensure it is marked for outdoor use.

1.2 GENERAL SAFETY

- ✓ Disconnect the cleaner from the power supply before servicing, changing accessories, or performing any maintenance.
- ✓ Use only genuine parts and accessories. *Unauthorised parts and accessories may be dangerous and will invalidate your warranty.*
- ✓ Maintain the cleaner in good condition. Use an authorised agent for servicing. Keep machine clean, but **DO NOT use solvents.**
- ✓ Ensure the correct paper filter bag is firmly in place before operating the cleaner. *Incorrect bags may cause machine faults and will invalidate your warranty.*
- ✓ Wear protective clothing and gloves.
- ✗ **DO NOT** allow children or untrained persons to operate the cleaner.
- ✗ **DO NOT** place attachments close to your face (especially eyes, ears, etc). Do not point the hose end at other persons or animals.
- ▲ **DANGER! DO NOT vacuum very fine powders, hot or glowing ash, inflammable, explosive, corrosive or other dangerous substances.**
- ✗ **DO NOT** operate the unit without the paper filter bag (except when wet vacuuming).
- ✗ **DO NOT** leave machine running unattended. Turn power supply OFF, and **DO NOT** leave the vicinity until motor has come to a complete stop.
- ✗ **DO NOT** operate the cleaner when you are tired, under the influence of alcohol, drugs or intoxicating medication.
- ✗ **DO NOT** use the cleaner in the rain or in very damp conditions.
- ✗ **DO NOT** use the cleaner for a task it is not designed to perform.
- ✓ When not in use, store the cleaner in a safe, dry, childproof location.

2. CONTENTS

2.1. Carton content

- 2.1.1. Release the side clips and lift the motor head from the bin. Take out the items in the bin. Replace and re-clip motor head.
- 2.1.2. Check and identify each accessory. If anything is missing or damaged contact your supplier immediately.

PC220 & PC230

- | | |
|----------------------|-------------------------------|
| 1. Floor Nozzle | 7. Elbow |
| 2. Triangular Nozzle | 8. Extension Tube (2) |
| 3. Crevice Tool | 9. Flexible Hose |
| 4. Brush Adaptor | 10. Base |
| 5. Liquids Adaptor | 11. Bin & Motor Head |
| 6. Curtain Nozzle | 12. Filter Cartridge (fitted) |

PC250

- | | |
|----------------------|------------------------|
| 1. Brush Frame | 7. Extension Tube (2) |
| 2. Liquid Brush | 8. Hose Elbow Joint |
| 3. Carpet Brush | 9. Hose 2m x 45mm |
| 4. Floor Brush | 10. Handle |
| 5. Triangular Nozzle | 11. Base |
| 6. Crevice Tool | 12. Bin and Motor Head |

3. SPECIFICATIONS & ASSEMBLY

PC220	Motor230V 1100W	Bin20ltr	Air Flow210m ³ /h	Weight7kg
PC230	Motor230V 1100W	Bin30ltr	Air Flow210m ³ /h	Weight7kg
PC250	Motor230V 1200W	Bin50ltr	Air Flow175m ³ /h	Weight12kg

3. Assembly

- 3.1.1. PC220/230 - Push fit bin to base, aligning inlet on bin with triangular mark on top edge of base. PC250 - Pull outwards catch at rear of base, place bin on base (seam to the rear) and release catch.
- 3.1.2. PC250 only - Slide handle through the four brackets on the bin and tighten clamping screws. The cleaner is now ready for **dry** vacuum cleaning. Note that PC250 has a two speed switch (1 & 2) as well as an On/Off switch (0 & 1) on top of the motor head.

Note: The filter cartridge is reusable. Remove (fig. 1), clean with a soft bristle brush and, if necessary, wash with a fine spray, from the inside out (fig. 2). When wet the filter cartridge is very easily damaged. Do not replace washed filter until it is dry. Replace the filter after approximately 100 working hours.

IMPORTANT! If using the optional paper dust bags, which fit over the suction inlet in the bin, **do not** remove the cartridge filter. The Dust bags should be changed when approximately two thirds full.

Always keep a pack of spare bags handy.

Paper Dust Bags - pack of 10 (Optional)Part No. 186/83015BOI (PC220/PC230), 186/83015B5I (PC250)

Foam Filter (Optional, for wet vacuuming)Part No. 186/83035BHB (all models)

Cartridge FilterPart No. VAC/92/DL (PC220/PC230), VAC92/250/DL (PC250)

4. WET VACUUM CLEANING

WARNING! Ensure you read, understand and apply Section 1 Safety Instructions.

DO NOT vacuum solvents, explosives, inflammable and/or hazardous liquids such as petrol, oil, spirits, paint, thinners, acids etc.

- 4.1. Ensure the machine is unplugged from the power supply.
- 4.2. Make sure the bin is clean and free from dust and dirt.
- 4.3. Remove the paper filter cartridge. Fitting foam filter is recommended.
- 4.4. To the same flexible hose as used in dry cleaning fit the crevice tool.
- 4.5. Ensure the switch is in the "Off" position and then plug the cleaner into the power supply.
- 4.6. To vacuum large quantities of liquid, from a sink, or tank, etc., do not immerse tool completely in the liquid, leave a gap at the top of the tool opening to allow an air inflow. See fig. 3.
- 4.7. The machine is fitted with a float valve which stops the suction action when the bin has reached its maximum capacity or if the cleaner is overturned. There will be an increase in motor speed. When this happens, turn off cleaner, disconnect from power supply, remove head from bin and empty liquid into a suitable receptacle or drain. To continue vacuuming, refit head and proceed.
- 4.8. After wet vacuuming, turn off the cleaner and disconnect from the power supply.

NOTE: The bin is **not** designed to store liquid, empty the bin after use, clean and dry the inside and outside before storage.

Remember! After wet vacuuming the paper filter cartridge **must** be refitted before dry vacuuming again.

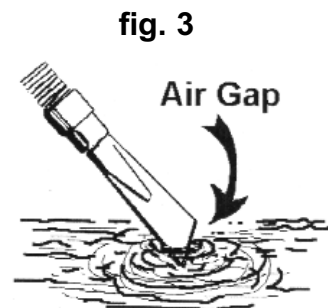
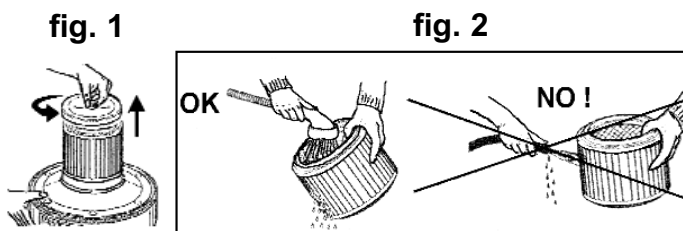

5. TROUBLESHOOTING

Cleaner will not operate.	No power supply. Faulty power cable, switch or motor. Container full of liquid.	Check supply. Check and repair or replace faulty item. Empty container.
Dust comes from the motor cover.	Filter cartridge missing or damaged.	Fit or replace.
Reduced efficiency and increased motor speed/vibration.	Paper filter bag and/or cartridge clogged. Nozzle, hose or bin inlet blocked.	Replace paper filter bag and/or clean cartridge. Check nozzle, hose and bin inlet for blockage.

Declaration of Conformity We, the sole UK importer, declare that the product listed below is in conformity with the following standards and directives. The construction files for these products are held by the Manufacturer and may be inspected, on request by a national authority to Jack Sealey Ltd.

Wet & Dry Vacuum Cleaner
Models: PC220, PC230 & PC250
 73/23/EEC Low Voltage Directive
 89/336/EEC EMC Directive
 93/68/EEC Marking Directive



Signed by Mark Sweetman



5th January 2004

For Jack Sealey Ltd. Sole UK importer of Sealey Quality Machinery.

NOTE: It is our policy to continually improve products and as such we reserve the right to alter data, specifications and component parts without prior notice.

IMPORTANT: No liability is accepted for incorrect use of this equipment.

WARRANTY: Guarantee is 12 months from purchase date, proof of which will be required for any claim.

INFORMATION: For a copy of our latest catalogue and promotions call us on 01284 757525 and leave your full name and address, including postcode.

	Sole UK Distributor, Sealey Group, Bury St. Edmunds, Suffolk.	01284 757500	sales@sealey.co.uk	www.sealey.co.uk
		01284 703534		



PARTS LIST FOR:

WET & DRY VACUUM CLEANERS

Models: PC220 & PC230

Issue No: 1
Date: 050104

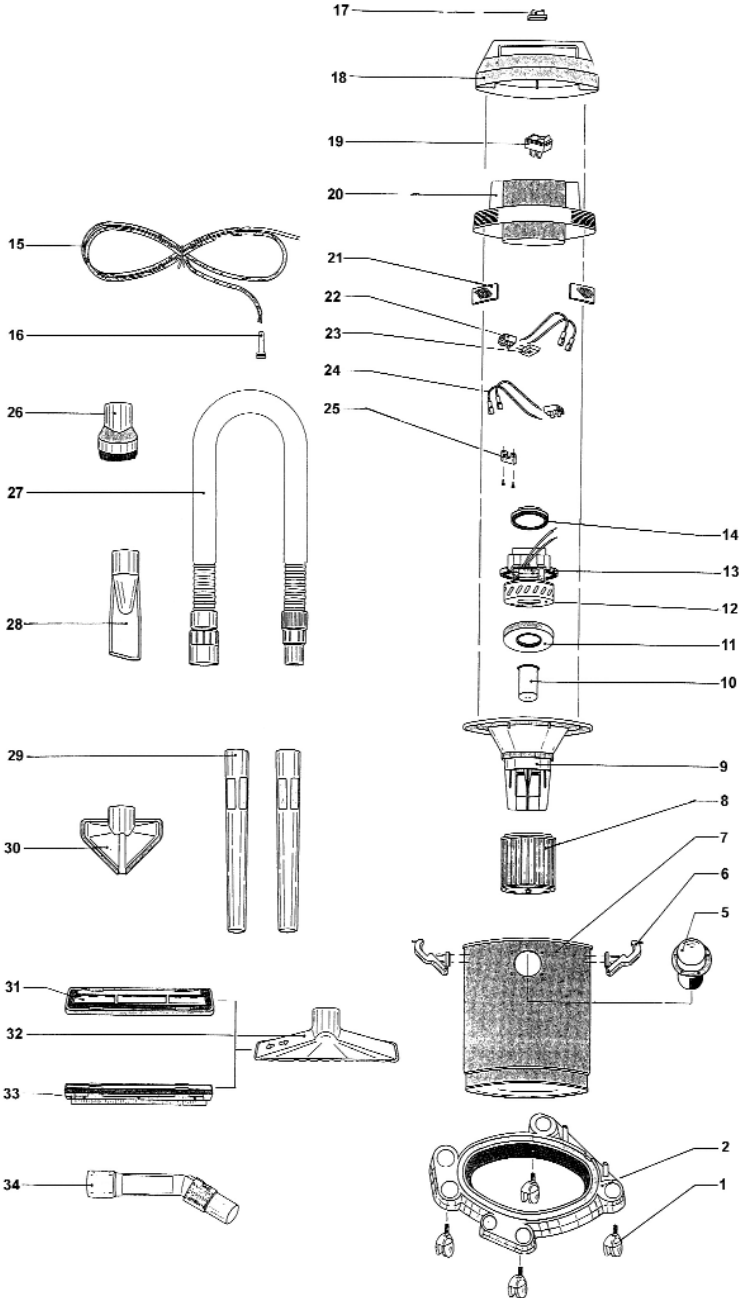

Item	Part No.	Description
1	186/30085BOX	Castor Wheel
2	186/01002BOA	Base
5	186/50079BOA	Hose Inlet
6	186/01016BOU	Bin Clip
7	186/10039BKM	Bin, Stainless Steel, 20 litre (PC220)
7	186/10038BGM	Bin, Stainless Steel, 30 litre (PC230)
8	VAC/92/DL	Cartridge Filter
9	186/50063BOU	Motor Cover, Lower c/w Float Cage
10	186/50077BOV	Float
11	186/70032BON	Motor Gasket, Lower
12	186/20007BOX	Motor
13	186/70033BON	Motor Gasket, Middle
14	186/70030BON	Motor Gasket, Upper
16	186/50036ZON	Cable Sleeve
17	186/70018BON	Cover, Switch
18	186/50186B6U	Motor Cover, Upper
19	186/80037BOX	Switch
20	186/50200BOA	Motor Cover, Middle
21	186/83102B6N	Filter Grille
22	186/80030ZOI	Cable Block
23	186/80021BOX	Noise Filter
24	186/80097BOV	Cable Connection
25	186/50078ZOX	Cable Grip
26	186/50081BOA	Curtain Brush
27	186/01317BON	Hose Complete, 1.5m x 45mm
28	186/50080BON	Crevice Tool
29	186/50091BON	Extension Tube
30	186/50089BOA	Triangular Nozzle
31	186/50085BON	Brush Adaptor
32	186/60277BON	Floor Nozzle
33	186/60278BON	Liquids Adaptor
34	186/50093BOA	Elbow

Spare Dust Collection Bags 186/83140BOK Packet of 5
 Bin/Lid Gasket 186/70017B5N
 Foam Filter 186/83035BHB



Sole UK Distributor,
 Sealey Group,
 Bury St. Edmunds, Suffolk.

01284 757500

01284 703534



sales@sealey.co.uk www.sealey.co.uk

