



# WET & DRY VACUUM CLEANER 20L, 1200W, STAINLESS DRUM

MODEL NO: **PC195SD.V3**

Thank you for purchasing a Sealey product. Manufactured to a high standard, this product will, if used according to these instructions, and properly maintained, give you years of trouble free performance.

**IMPORTANT:** PLEASE READ THESE INSTRUCTIONS CAREFULLY. NOTE THE SAFE OPERATIONAL REQUIREMENTS, WARNINGS & CAUTIONS. USE THE PRODUCT CORRECTLY AND WITH CARE FOR THE PURPOSE FOR WHICH IT IS INTENDED. FAILURE TO DO SO MAY CAUSE DAMAGE AND/OR PERSONAL INJURY AND WILL INVALIDATE THE WARRANTY. KEEP THESE INSTRUCTIONS SAFE FOR FUTURE USE.



Refer to  
instructions



Wear eye  
protection

## 1. SAFETY

### 1.1. ELECTRICAL SAFETY

- WARNING!** It is the user's responsibility to check the following:
- ✓ Check all electrical equipment and appliances to ensure that they are safe before using. Inspect power supply leads, plugs and all electrical connections for wear and damage. Sealey recommend that an RCD (Residual Current Device) is used with all electrical products.
- ✓ **Electrical safety information. It is important that the following information is read and understood:**
- ✓ Ensure that the insulation on all cables and on the appliance is safe before connecting it to the power supply.
- ✓ Regularly inspect power supply cables and plugs for wear or damage and check all connections to ensure that they are secure.  
**Important:** Ensure that the voltage rating on the appliance suits the power supply to be used and that the plug is fitted with the correct fuse.
- ✗ **DO NOT** pull or carry the appliance by the power cable.
- ✗ **DO NOT** pull the plug from the socket by the cable.
- ✗ **DO NOT** use worn or damaged cables, plugs or connectors. Ensure that any faulty item is repaired or is replaced immediately by a Qualified electrician.

If the cable or plug is damaged during use, switch off the electricity supply and remove from use.

**Ensure that repairs are carried out by a qualified electrician.**

### 1.2. GENERAL SAFETY

- ✓ Disconnect the cleaner from the power supply before servicing, changing accessories, or performing any maintenance.
- ✓ Use only genuine parts and accessories. Unauthorised parts and accessories may be dangerous and will invalidate your warranty.
- ✓ Maintain the cleaner in good condition. Use an authorised agent for servicing. Keep machine clean, but **DO NOT** use solvents.
- ✓ For dry vacuuming ensure the dry reusable filter (section 5), is in place before operating the cleaner.
- ✓ For wet vacuuming ensure the wet filter (section 8), is in place before operating the cleaner.
- WARNING!** Using the cleaner without the appropriate filters may cause damage to the vacuum cleaner and will invalidate your warranty.
- ✓ Wear protective clothing and gloves.
- ✗ **DO NOT** place attachments close to your face (especially eyes, ears, etc). **DO NOT** point the hose end at other persons or animals.
- ▲ **DANGER! DO NOT** vacuum hot or glowing ash, cigarette ends, flammable, explosive, corrosive or other dangerous substances.
- ✗ **DO NOT** leave machine running unattended. Turn power supply OFF, and **DO NOT** leave the vicinity until motor has come to a complete stop.
- ✗ **DO NOT** operate the cleaner while under the influence of drugs, alcohol or impairing medication, or if you are tired.
- ✗ **DO NOT** use the cleaner in the rain or in very damp conditions.
- ✗ **DO NOT** use the cleaner for a task it is not designed to perform.
- ✓ When not in use, store the cleaner in a safe, dry, childproof location.  
**NOTE:** This appliance can be used by children aged from 8 years and above and persons with reduced physical, sensory or mental capabilities or lack of experience and knowledge if they have been given supervision or instruction concerning use of the appliance in a safe way and understand the hazards involved. Children shall not play with the appliance. Cleaning and user maintenance shall not be made by children without supervision.

## 2. INTRODUCTION

Powerful 1200W motor is perfect for garages, workshops, commercial or domestic use. Rust-proof 20L stainless steel drum is easy to empty and clean after use. Cleaning function reverses the airflow to effectively clean the filter and restores up to 80% suction. Fitted with 3.7m cable and 1.5m suction hose. Supplied with accessory tool kit, including three rigid extension tubes, crevice nozzle, floor nozzle, wet-use foam filter and cloth filter. Fitted with four swivel castor wheels for maximum manoeuvrability.

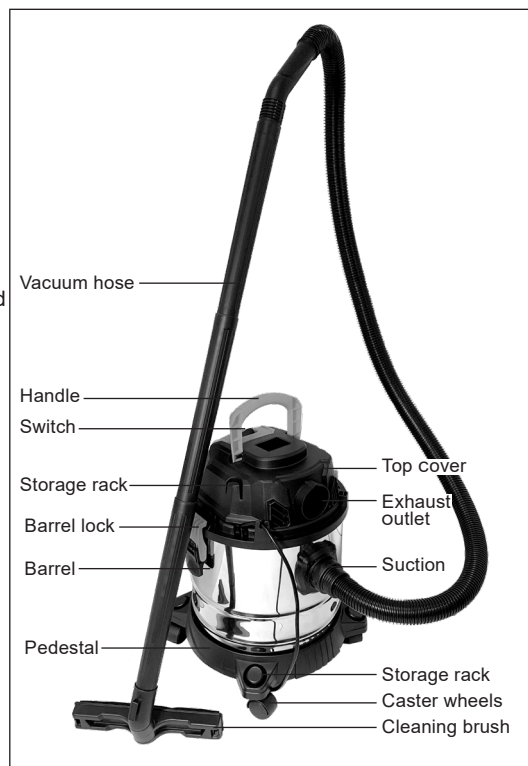

### 3. SPECIFICATION

Model No:	PC195SD.V3
Drum Size:	20L
Filter Type:	Cartridge Foam
Fuse Rating:	13A
Maximum Vacuum Pressure:	170mbar

Motor Power:	1200W
Plug Type:	3-Pin
Power Supply Cable Length:	3.6m
Supply:	230V
Vacuum Accessories Diameter:	Ø35mm

### 4. ASSEMBLY FIG.1.

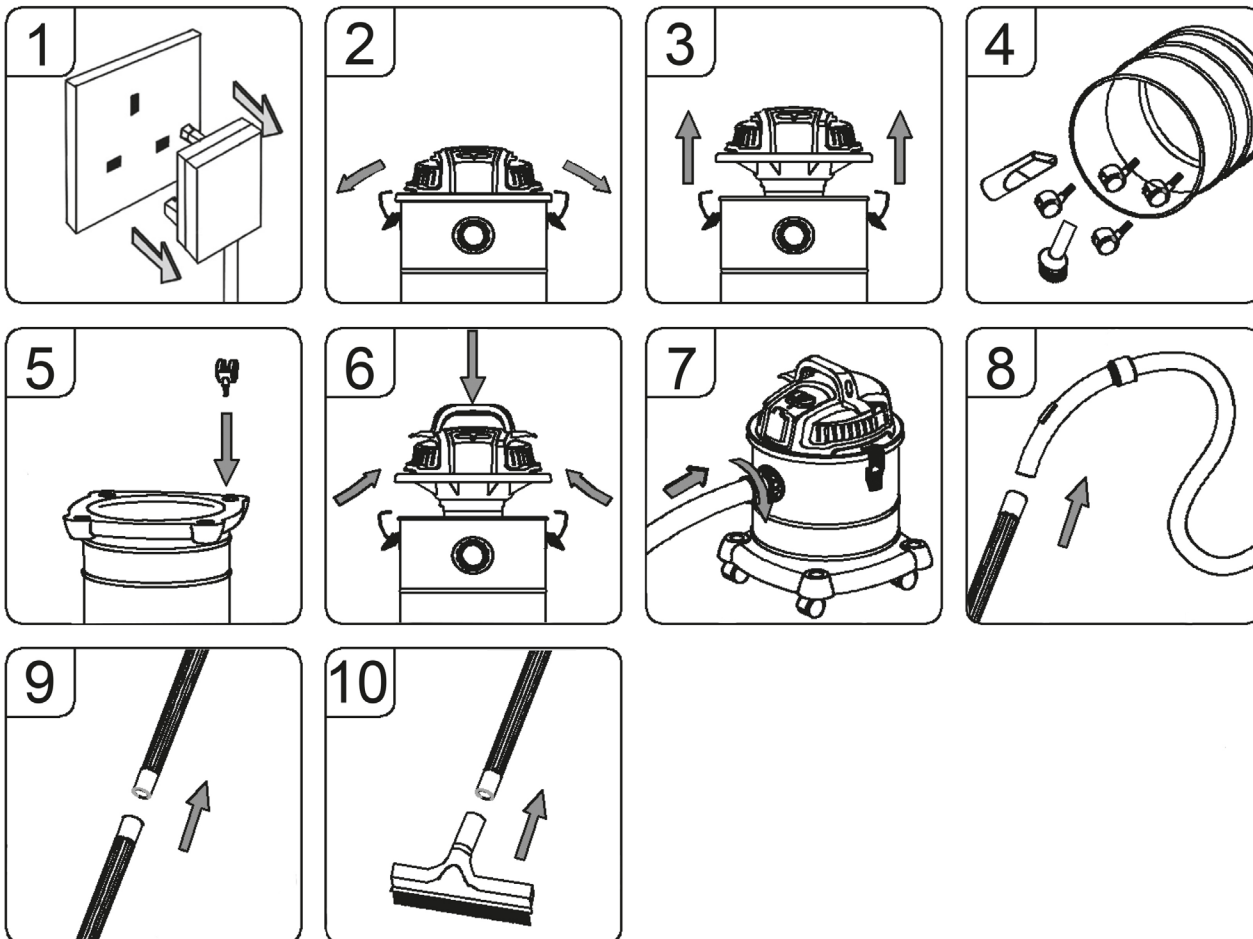

❑ **WARNING!** make sure vacuum is unplugged before assembly (fig.1.1).

#### 4.1. OPEN VACUUM CLEANER

- 4.1.1. Undo barrel locks (fig.1.2).
- 4.1.2. Raise the top cover assembly from the dust barrel (fig.1.3).
- 4.1.3. Remove all of the accessories from the dust barrel (fig.1.4).
- 4.1.4. Turn the container upside down and insert the four castor wheels. Check that they are mounted correctly (fig.1.5).
- 4.1.5. Place the top cover assembly on the dust barrel and lock it in place with both of the barrel locks (fig.1.6).
- 4.1.6. Align the hose assembly port with the suction port, insert and twist it to the right to tighten (fig.1.7).
- 4.1.7. The hose can be extended by using the three extension tubes, push together to fit to hose (fig.1.8).
- 4.1.8. To extend the hose use the extension tubes, push the tubes together (fig.1.9).
- 4.1.9. To attach the brush, push onto the tube extension (fig.1.10).

### 5. DRY VACUUMING FIG.2.

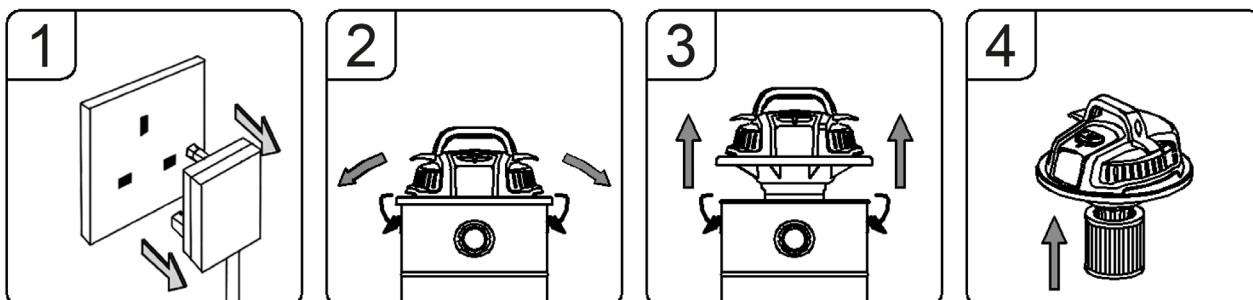

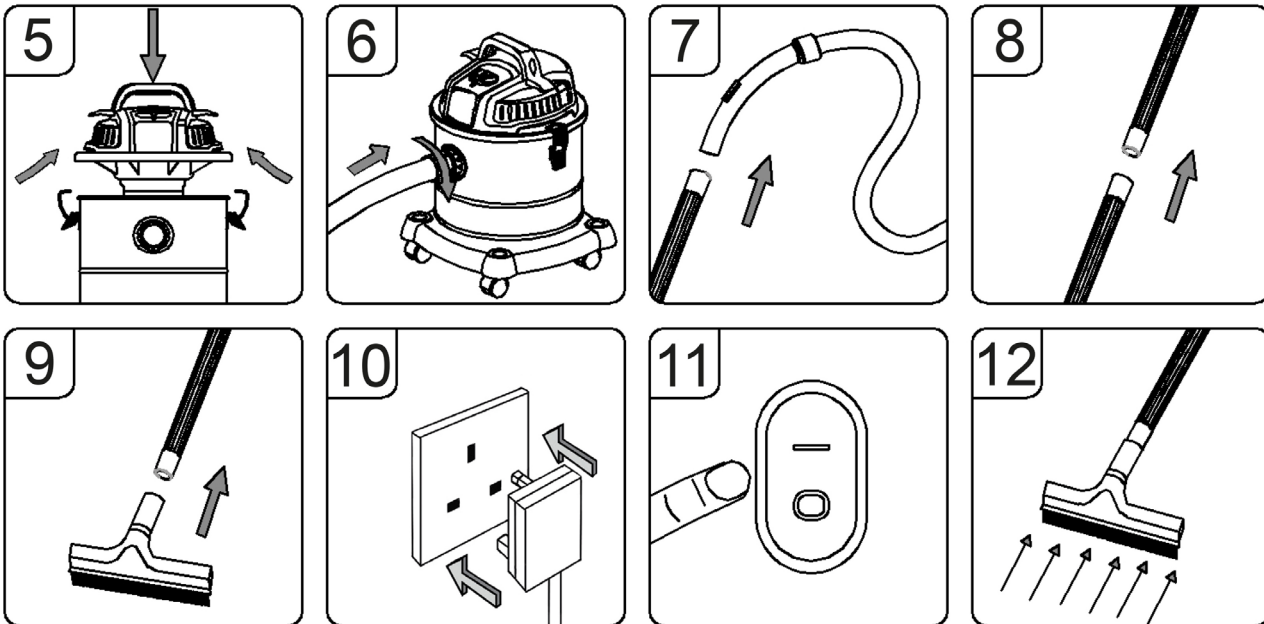

- 5.1.3. Install Hepa filter in the correct position (fig.2.4).
- 5.1.4. Put the top cover assembly on the dust barrel and lock it in place with the clips (fig.2.5).
- 5.1.5. Insert the hose connector into the air inlet as shown, make sure the connector is tightly fastened (fig.2.6).
- 5.1.6. Connect the tube to the hose assembly (fig.2.7).
- 5.1.7. Connect three tubes (fig.2.8).
- 5.1.8. Connect tubes and floor nozzle (fig.2.9).
- 5.1.9. Plug the machine in (fig.2.10).
- 5.1.10. Switch on the machine (fig.2.11).
- 5.1.11. Start vacuuming (fig.2.12).
- ❑ **WARNING! DO NOT** suck dust and liquid at the same time.

## 6. EMPTYING THE DUST BARREL FIG.3.

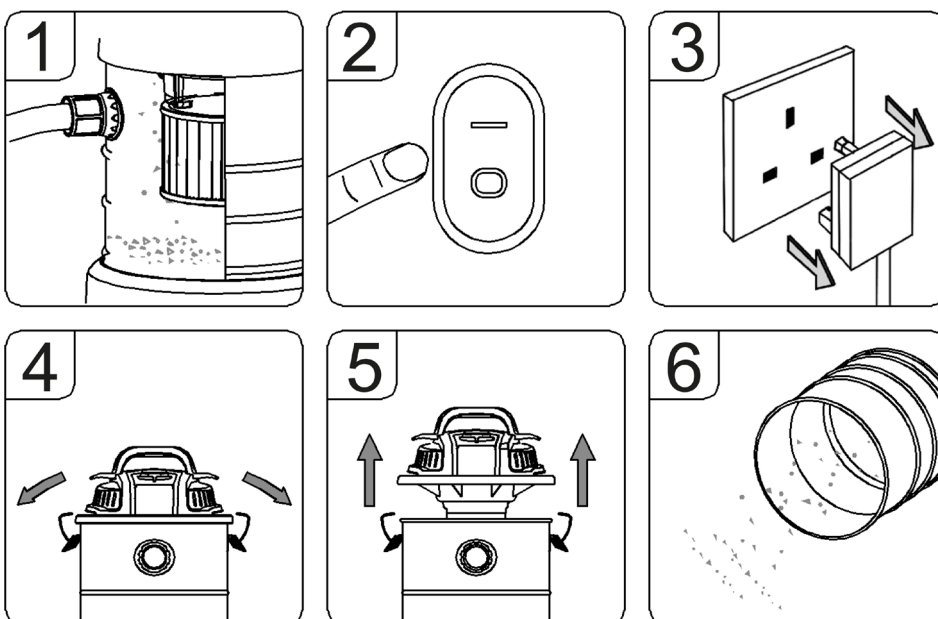

- 6.1.1. When the barrel is full of dust (fig.3.1).
- 6.1.2. Turn off the machine (fig.3.2).
- 6.1.3. Unplug the cable (fig.3.3).
- 6.1.4. Release the barrel lock (fig.3.4).
- 6.1.5. Raise the top cover assembly from the dust container (fig.3.5).
- 6.1.6. Empty the debris from the barrel (fig.3.6).

## 7. HEPA FILTER CLEANING FIG.4

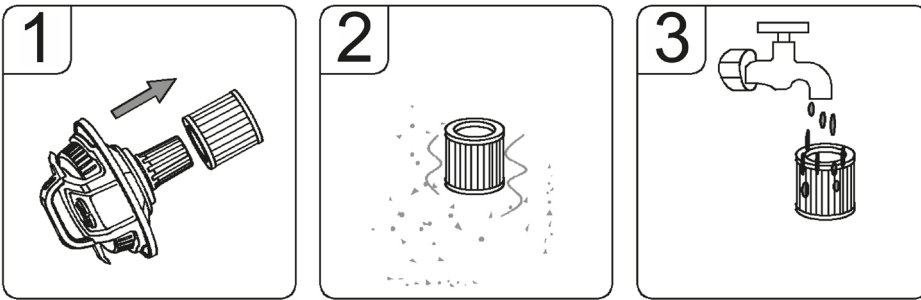

7.1. The Hepa filter should be washed using clean warm water when it is covered with dust. If very soiled use a mild detergent to wash the filter.

7.1.1. Remove Hepa filter (fig.4.1).

7.1.2. Shake off dust (fig.4.2).

7.1.3. Wash allow to dry before installing (fig.4.3).

## 8. WET VACUUMING FIG.5

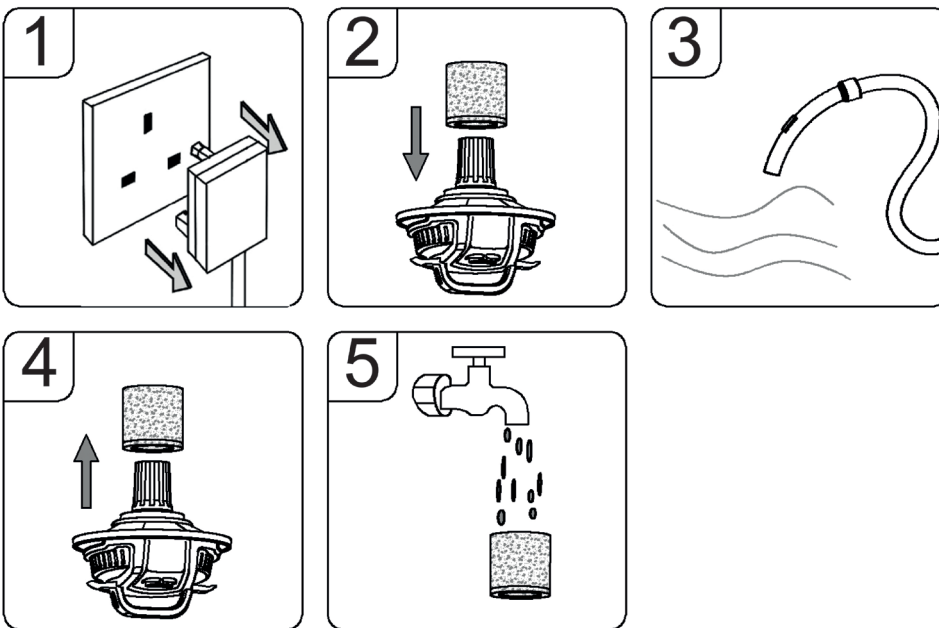

❑ **WARNING!** Make sure the vacuum is unplugged (fig.5.1).

8.1.1. Install air inlet filter sponge on top cover basket, make sure the cover is correctly installed (fig.5.2).

8.1.2. When the barrel reaches its maximum capacity, the safety valve will automatically stop the suction action. Disconnect from the mains, and drain the liquid into a suitable receptacle or drain (fig.5.3).

8.1.3. Each time you empty the barrel wring the sponge filter dry (fig.5.4).

Clean air inlet filter sponge with water or with water and a mild detergent, then wring dry, this can be used again (fig.5.5). After wet vacuuming, turn the machine off and remove the plug. Empty the container, clean and dry the machine inside and outside before storage.

## 9. BLOWING FIG.6

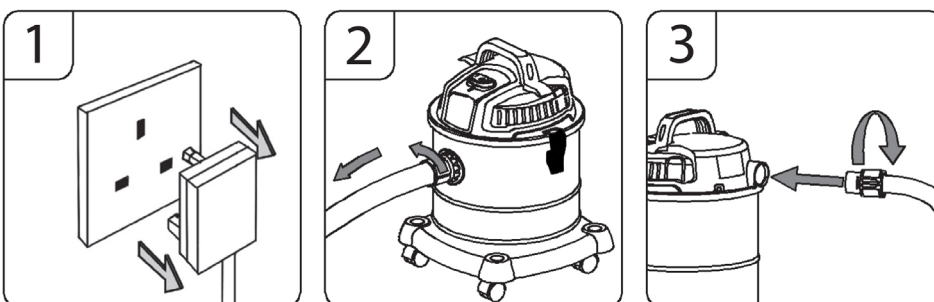

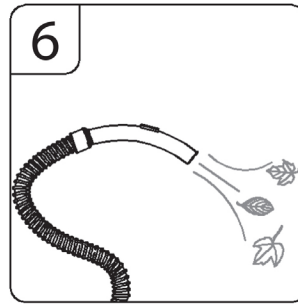
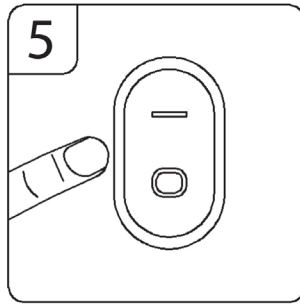
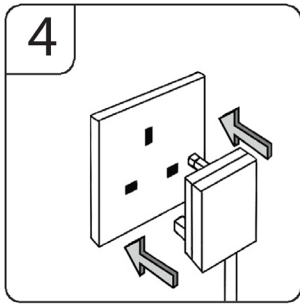

- ❑ **WARNING!** Make sure the vacuum is unplugged (fig.6.1).
- 9.1.1. Unscrew the hose from the suction port (fig.6.2).
- 9.1.2. Insert the hose assembly into the blower socket (on the back of the top cover), rotate it to the right and tighten it (fig.6.3).
- 9.1.3. Plug in the machine (fig.6.4).
- 9.1.4. Switch on the machine (fig.6.5).
- 9.1.5. The unit will now blow through the vacuum hose and can be used to clear obstructions within the hose (fig.6.6).
- ❑ **WARNING!** Before using the blower function, make sure the container is empty.
- ❑ **WARNING!** Always wear safety goggles before using the blower. Keep bystanders away from blowing debris and wear a dust mask if blowing creates dust that might be inhaled.

## 10. ACCESSORIES FIG.7

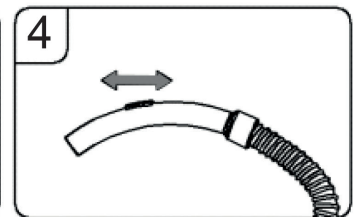
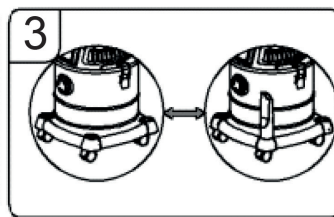
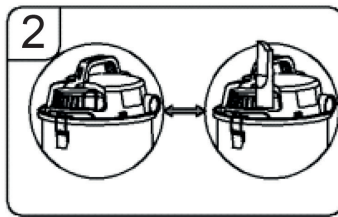
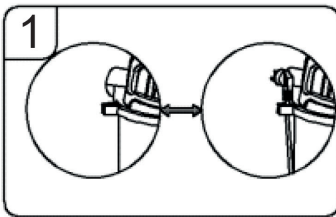

- 10.1. Power cable winding (fig.7.1).
- 10.2. Storage brush, crevice nozzle, (fig.7.2).
- 10.3. Storage brush, crevice nozzle, floor nozzle, tubes (fig.7.3).
- 10.4. Adjust airflow (fig.7.4).

## 11. MAINTENANCE

- ❑ **WARNING!** remove from mains supply.
- 11.1. After cleaning the barrel, filters and related accessories, check for leaks. After each use, clean the filter, never use a wet filter.
- 11.2. Check the plug for damage, if found to be damaged replace the plug.
- 11.3. If suction is reduced check to see if the air intake is blocked, clear any blockages.
- 11.4. Carefully empty the machine, **DO NOT** hit the barrel.
- 11.5. Keep the machine dry.
- 11.6. After prolonged use the filter will be covered with dust, and suction will be reduced. To avoid reducing the suction, clean the filter regularly. If the filter is covered with dust, wash with water, if necessary, use a mild detergent, refer to section 7.
- \* **DO NOT** use abrasives to clean.
- \* **DO NOT** put entire top cover assembly directly into the water.
- \* **DO NOT** let the machine work for more than 2 hours at a time, doing so will reduce the life of the machine.
- 11.7. If any abnormal vibrations, noises or smells occur stop using the machine immediately.



### ENVIRONMENT PROTECTION

Recycle unwanted materials instead of disposing of them as waste. All tools, accessories and packaging should be sorted, taken to a recycling centre and disposed of in a manner which is compatible with the environment. When the product becomes completely unserviceable and requires disposal, drain any fluids (if applicable) into approved containers and dispose of the product and fluids according to local regulations.



REGISTER YOUR PURCHASE HERE



### WEEE REGULATIONS

Dispose of this product at the end of its working life in compliance with the EU Directive on Waste Electrical and Electronic Equipment (WEEE). When the product is no longer required, it must be disposed of in an environmentally protective way. Contact your local solid waste authority for recycling information.

**NOTE:** It is our policy to continually improve products and as such we reserve the right to alter data, specifications and component parts without prior notice. Please note that other versions of this product are available. If you require documentation for alternative versions, please email or call our technical team on [technical@sealey.co.uk](mailto:technical@sealey.co.uk) or 01284 757505.

**IMPORTANT:** No Liability is accepted for incorrect use of this product.

**WARRANTY:** Guarantee is 12 months from purchase date, proof of which is required for any claim.

Sealey Group, Kempson Way, Suffolk Business Park, Bury St Edmunds, Suffolk. IP32 7AR



01284 757500



[sales@sealey.co.uk](mailto:sales@sealey.co.uk)



[www.sealey.co.uk](http://www.sealey.co.uk)