



# BUILDERVAC® WET & DRY VACUUM CLEANER, M CLASS FILTRATION, STAINLESS STEEL DRUM, 15L, 230V/110V, 1400W

MODEL NO: **PC150BV, PC150BV110V**

Thank you for purchasing a Sealey product. Manufactured to a high standard, this product will, if used according to these instructions, and properly maintained, give you years of trouble free performance.

**IMPORTANT:** PLEASE READ THESE INSTRUCTIONS CAREFULLY. NOTE THE SAFE OPERATIONAL REQUIREMENTS, WARNINGS & CAUTIONS. USE THE PRODUCT CORRECTLY AND WITH CARE FOR THE PURPOSE FOR WHICH IT IS INTENDED. FAILURE TO DO SO MAY CAUSE DAMAGE AND/OR PERSONAL INJURY AND WILL INVALIDATE THE WARRANTY. KEEP THESE INSTRUCTIONS SAFE FOR FUTURE USE.



Refer to instructions



Wear eye protection



Wear a mask



Wear protective clothing



Wear a P-2 respirator when changing bags, filter or cartridges



Vacuum cleaners of dust category M according to IEC/EN 60335-2-69 for dry vacuuming of hazardous dusts with an exposition limit value  $\geq 0.1 \text{ mg/m}^3$

## 1. SAFETY

### 1.1. ELECTRICAL SAFETY

- WARNING!** – Read the instruction manual before using the machine
  - WARNING!** It is the user's responsibility to check the following:
    - ✓ Check all electrical equipment and appliances to ensure that they are safe before using. Inspect power supply leads, plugs and all electrical connections for wear and damage. Sealey recommend that an RCD (Residual Current Device) is used with all electrical products.
  - Electrical safety information. It is important that the following information is read and understood:**
    - ✓ Ensure that the insulation on all cables and on the appliance is safe before connecting it to the power supply.
    - ✓ Regularly inspect power supply cables and plugs for wear or damage and check all connections to ensure that they are secure.
  - Important:** Ensure that the voltage rating on the appliance suits the power supply to be used and that the plug is fitted with the correct fuse.
  - ✗ **DO NOT** pull or carry the appliance by the power cable.
  - ✗ **DO NOT** pull the plug from the socket by the cable.
  - ✗ **DO NOT** use worn or damaged cables, plugs or connectors. Ensure that any faulty item is repaired or is replaced immediately by a qualified electrician.
- If the cable or plug is damaged during use, switch off the electricity supply and remove from use. If the supply cord is damaged, it must be replaced by the manufacturer, its service agent or similarly qualified persons in order to avoid a hazard.

### 1.2. GENERAL SAFETY

- ✗ Children shall NOT play with the appliance.
- ✗ This machine is not intended for use by persons (including children) with reduced physical, sensory, or mental capabilities, or lack of experience and knowledge.
- ✓ Cleaning and user maintenance on the appliance shall not be made by children without supervision.
- ✓ The appliance shall be disconnected from its power source during service and when replacing parts. In the event of a breakdown, disconnect from mains supply and get product repaired by a qualified engineer.
- ✓ Use only genuine parts and accessories. Unauthorised parts and accessories may be dangerous and will invalidate your warranty.
- ✓ Maintain the cleaner in good condition. Use an authorised agent for servicing. Keep machine clean, but **DO NOT** use solvents.
- ✓ For dry vacuuming ensure the dry reusable filter (section 6), is in place before operating the cleaner.
- ✓ For wet vacuuming ensure the wet filter (section 10), is in place before operating the cleaner.
- WARNING!** Using the cleaner without the appropriate filters may cause damage to the vacuum cleaner and will invalidate your warranty.
- ✓ Wear protective clothing and gloves.
- ✗ **DO NOT** place attachments close to your face (especially eyes, ears, etc). **DO NOT** point the hose end at other persons or animals.
- ▲ **DANGER! DO NOT** vacuum hot or glowing ash, cigarette ends, flammable, explosive, corrosive or other dangerous substances.
- ✗ **DO NOT** leave machine running unattended. Turn power supply OFF, and **DO NOT** leave the vicinity until motor has come to a complete stop.
- ✗ **DO NOT** operate the cleaner while under the influence of drugs, alcohol or impairing medication, or if you are tired.
- ✗ **DO NOT** use the cleaner in the rain or in very damp conditions.
- ✗ **DO NOT** use the cleaner for a task it is not designed to perform.
- ✓ When not in use, store the cleaner in a safe, dry, childproof location.
- ✓ This machine is intended for commercial use, for example in hotels, schools, hospital, factories, shops, offices, and rental business.
- WARNING!** Operators shall be adequately instructed on the use of these machines.
- WARNING!** This machine is for indoor use only.
- WARNING!** This machine shall be stored indoors only.

## 2. INTRODUCTION

M Class filtration filters particles down to 1 micron, minimising exposure and safely contains potentially harmful dust particles. Fitted with a shut-off valve and sponge filter for vacuuming liquid or HEPA cartridge filter for dry vacuuming. Durable painted stainless steel drum is mounted on four swivel castors for easy manoeuvrability and positioning. Filter shake cleaning function reverses the airflow to effectively clean the filter and restores suction. This also means the vacuum can be used as a blower. Features power tool plug socket that automatically turns the vacuum on/off when a power tool is turned on/off. Fitted with 4m cable and 1.5m suction hose. Supplied with three aluminium extension tubes, cartridge filter, wet-use foam filter, dust collection bag, power tool adaptor, floor brush, crevice tool and round brush.

## 3. CONTENTS (SEE RIGHT)

## 4. SPECIFICATION

Model No:	PC150BV	PC150BV110V
Barrel Size:	15L	15L
Barrel Type:	Stainless Steel	Stainless Steel
Fuse Rating:	13A	N/A
Maximum Vacuum Pressure:	17KPa	17KPa
Motor Power:	1400W	1400W
Nett Weight:	6.54kg	6.50kg
Plug Type:	3-pin	Yellow - 32A-2P+E
Power Supply Cable Length:	4m	4m
Power Tool Capacity:	1500W	750W
Replacement Parts:	PC150BVCF - M Class HEPA Filter, PC150BVCB - M Class Cloth Bag, PC150BVFF - Foam Filter	PC150BVCF - M Class HEPA Filter, PC150BVCB - M Class Cloth Bag, PC150BVFF - Foam Filter
Supply:	230V	110V
Vacuum Accessories Diameter:	Ø32mm	Ø32mm

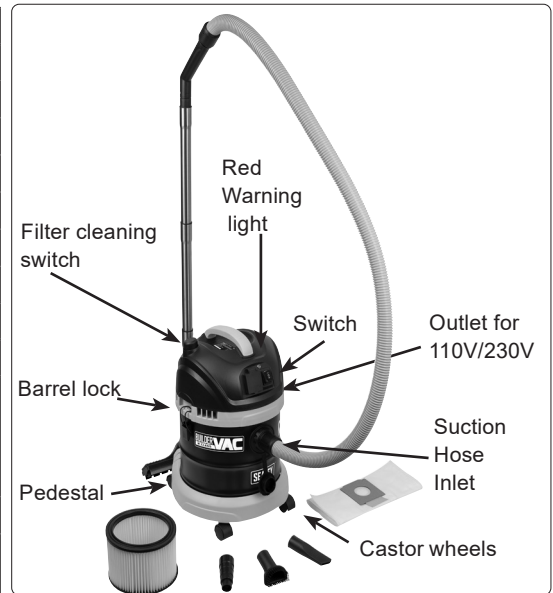

Supplied with three aluminium extension tubes, cartridge filter, wet-use foam filter (not shown), hepa filter, dust collection bag, power tool adaptor, floor brush, crevice tool and round brush.

## 5. ASSEMBLY FIG.1.

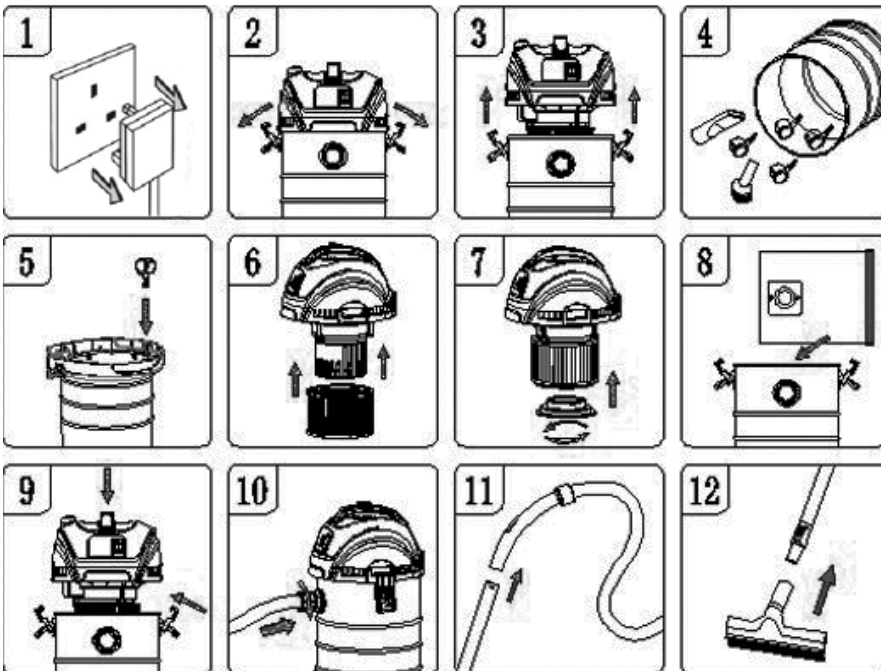

❑ **WARNING!** Disconnect from mains supply before assembly (fig.1.1).

### 5.1. OPEN VACUUM CLEANER

- 5.2. Undo barrel locks (fig.1.2).
- 5.3. Raise the top cover assembly from the dust barrel (fig.1.3).
- 5.4. Remove all of the accessories from the dust barrel (fig.1.4).
- 5.5. Turn the container upside down and insert the four castor wheels. Check that they are mounted correctly (fig.1.5).
- 5.6. Install the hepa filter by applying light pressure between the bottom of the filter and the top of the handle assembly (fig.1.6).
- 5.7. Place one hand on the handle assembly then with the other hand secure the basket with its retainer turning clockwise until it is hand tight (fig.1.7).
- 5.8. Install the cloth bag into the suction slot inside the barrel (fig.1.8).
- 5.9. Place the top cover assembly on the dust barrel and lock it in place with both of the barrel locks (fig.1.9).

- 5.10. Align the hose assembly port with the suction port, insert and twist it to the right to tighten (fig.1.10).
- 5.11. The hose can be extended by using the extension tubes (fig.1.11).
- 5.12. To attach the brush, push onto the tube extension (fig.1.12).

## 6. DRY VACUUMING FIG.2

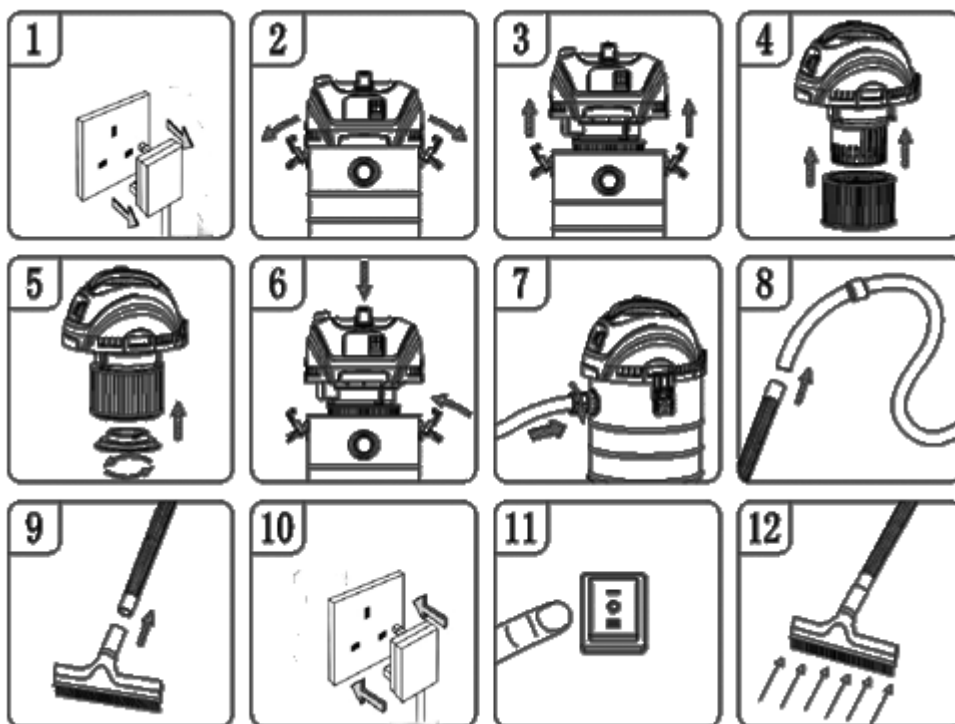

- ❑ **WARNING!** Disconnect from mains supply (fig.2.1).
- 6.1. Release the barrel locks (fig.2.2).
- 6.2. Lift the top cover assembly from the dust barrel (fig.2.3).
- 6.3. Check hepa filter is fitted if not install hepa filter in the correct position (fig.2.4 and fig.2.5).
- 6.4. Put the top cover assembly on the dust barrel and lock it in place with the clips (fig.2.6).
- 6.5. Insert the hose connector barrel into the air inlet as shown, make sure the connector is tightly fastened (fig.2.7).
- 6.6. Connect the tube to the hose assembly (fig.2.8).
- 6.7. Connect three tubes (fig.2.8 and fig.2.9).
- 6.8. Connect tubes to floor nozzle (fig.2.9).
- 6.9. Plug the machine in (fig.2.10).
- 6.10. Switch on the machine (fig.2.11).
- 6.11. Start vacuuming (fig.2.12).
- ❑ **WARNING! DO NOT** vacuum dust and liquid at the same time.

## 7. BLOCKAGE WARNING FIG.3

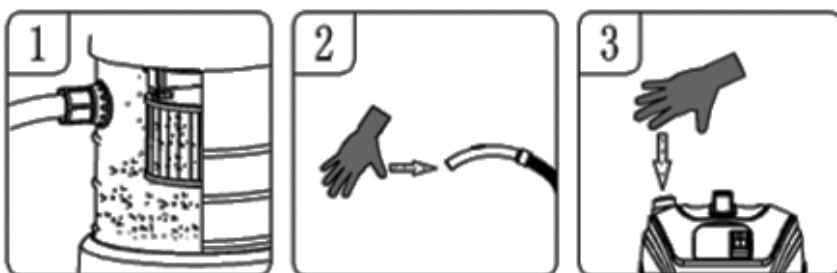

- 7.1. When suction becomes weak the red warning light will turn red.(See Fig.3.1 and contents)
- 7.2. Block the inlet by hand. (fig.3.2)
- 7.3. Press the button (Fig.3.3). 2-3 seconds each time and then release, repeat 5-10 times, suction should recover.

## 8. EMPTYING THE DUST BARREL FIG.4

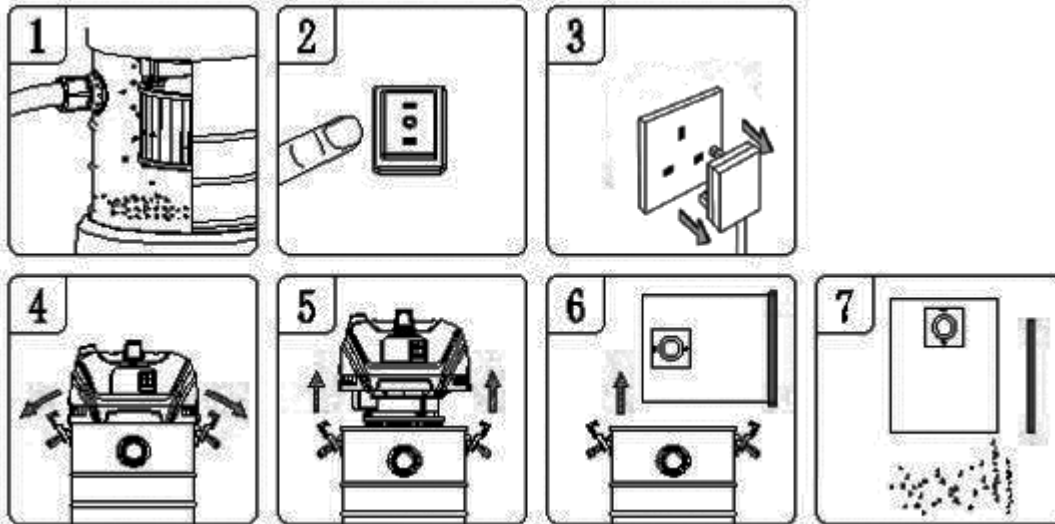

- 8.1. When the barrel is full (fig.4.1).
- 8.2. Turn off the machine (fig.4.2).
- 8.3. Disconnect from mains supply (fig.4.3).
- 8.4. Release the barrel locks (fig.4.4).
- 8.5. Raise the top cover assembly from the dust container (fig.4.5).
- 8.6. Remove the cloth bag from the bucket (fig.4.6)
- 8.7. Empty the debris from the barrel (fig.4.7).

## 9. HEPA FILTER CLEANING FIG.5



- 9.1. If performance is reduced, it may be that the hepa filter is starting to get clogged.
  - 9.1.1. The filter can be blown through by pressing the filter cleaning switch 2-3 seconds each time and then released, repeat 5-10 times, suction should recover.
- 9.2. If the process above does not deliver a significant result, the hepa filter should be washed using clean warm water when it is covered with dust. If very soiled use a mild detergent to wash the filter.
  - 9.2.1. Remove Hepa filter (fig.5.1).
  - 9.2.2. Shake off dust (fig.5.2).
  - 9.2.3. Wash and allow to dry before installing (fig.5.)

## 10. WET VACUUMING FIG.6

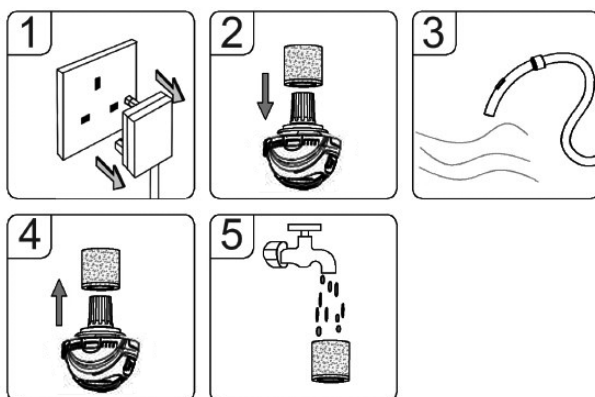

- ❑ **WARNING!** Make sure the vacuum is unplugged (fig.6.1).
- 10.1. Release the barrel locks (fig.4.4). Lift the top cover assembly from the dust barrel (fig.4.5).
  - 10.2. Install air inlet filter sponge on top cover basket, make sure the cover is correctly installed (fig.6.2).
  - 10.3. When the barrel reaches its maximum capacity, the safety valve will automatically stop the suction action. Disconnect from the mains, and drain the liquid into a suitable receptacle or drain (fig.6.3).
  - 10.4. Each time you empty the barrel wring the sponge filter dry (fig.6.4).

- 10.5. Clean air inlet filter sponge with water or with water and a mild detergent, then wring dry, this can be used again (fig.6.5). After wet vacuuming, turn the machine off and remove the plug. Empty the container, clean and dry the machine inside and outside before storage.

## 11. ACCESSORIES STORAGE FIG.7

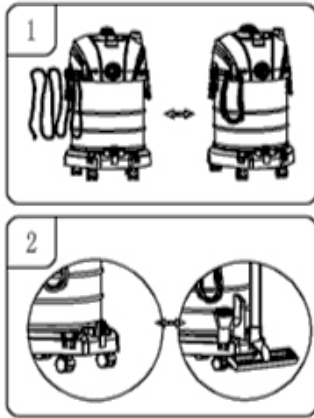

- 11.1. Power cable winding (fig.7.1).  
 11.2. Storage of brush, crevice nozzle, floor nozzle, tubes (fig.7.2).

## 12. OUTLET SOCKET 110V/230V FIG.8

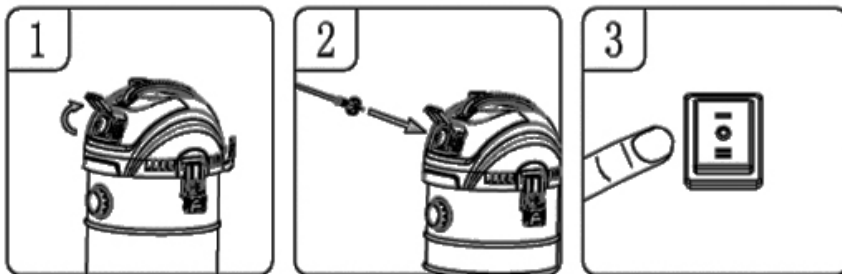

- ❑ **WARNING!** Switch off vacuum and disconnect from mains supply before continuing.
- 12.1. Open the outlet power tool socket (fig.8.1).
- 12.2. Plug in power tool cable (fig.8.2).
- 12.3. Plug in mains supply to vacuum.
- ❑ **WARNING!** Ensure there are no obstructions in the pathway of the power tool .
- 12.4. Fig.8.3 shows the operation switch. The first stage is marked with the figure (I) which operates just the vacuum, the 0 is the off position and the second stage marked (II) will supply an auxiliary device with power.”

## 13. MAINTENANCE

- ❑ **WARNING!** Remove from mains supply.
- ❑ **WARNING!** ALWAYS USE A P2-RESPIRATOR WHEN PERFORMING ANY MAINTENANCE AND/OR REMOVING THE CARTRIDGE FILTER AFTER VACUUMING HAZARDOUS DUSTS.
- 13.1. After cleaning the barrel, filters and related accessories, check for leaks. After each use, clean the filter, never use a wet filter.
- 13.2. If suction is reduced check to see if the air intake is blocked, clear any blockages.(section 7).
- 13.3. Carefully empty the machine, **DO NOT** damage the barrel.
- 13.4. Keep the machine dry.
- 13.5. After prolonged use the filter will be covered with dust, and suction will be reduced. To avoid reducing the suction, clean the filter regularly. If the filter is covered with dust, wash with water, if necessary, use a mild detergent, refer to section 7 and 9.
- × **DO NOT** use abrasives to clean.
- × **DO NOT** put entire top cover assembly directly into the water.
- × **DO NOT** let the machine work for more than 2 hours at a time, doing so will reduce the life of the machine.
- 13.6. If any abnormal vibrations, noises or smells occur stop using the machine immediately.



#### ENVIRONMENT PROTECTION

Recycle unwanted materials instead of disposing of them as waste. All tools, accessories and packaging should be sorted, taken to a recycling centre and disposed of in a manner which is compatible with the environment. When the product becomes completely unserviceable and requires disposal, drain any fluids (if applicable) into approved containers and dispose of the product and fluids according to local regulations.



REGISTER YOUR  
PURCHASE HERE



#### WEEE REGULATIONS

Dispose of this product at the end of its working life in compliance with the EU Directive on Waste Electrical and Electronic Equipment (WEEE). When the product is no longer required, it must be disposed of in an environmentally protective way. Contact your local solid waste authority for recycling information.

**Note:** It is our policy to continually improve products and as such we reserve the right to alter data, specifications and component parts without prior notice.

**Important:** No Liability is accepted for incorrect use of this product.

**Warranty:** Guarantee is 12 months from purchase date, proof of which is required for any claim.

Sealey Group, Kempson Way, Suffolk Business Park, Bury St Edmunds, Suffolk. IP32 7AR



01284 757500



sales@sealey.co.uk



www.sealey.co.uk