



SCHUMACHER 500/1500HP 12/24V WHEELED ROADSTART® EMERGENCY JUMP STARTER

MODEL NO'S: PBIW4600, PBIW6200

Thank you for purchasing a Sealey product. Manufactured to a high standard, this product will, if used according to these instructions, and properly maintained, give you years of trouble free performance.

IMPORTANT: PLEASE READ THESE INSTRUCTIONS CAREFULLY. NOTE THE SAFE OPERATIONAL REQUIREMENTS, WARNINGS & CAUTIONS. USE THE PRODUCT CORRECTLY AND WITH CARE FOR THE PURPOSE FOR WHICH IT IS INTENDED. FAILURE TO DO SO MAY CAUSE DAMAGE AND/OR PERSONAL INJURY AND WILL INVALIDATE THE WARRANTY. KEEP THESE INSTRUCTIONS SAFE FOR FUTURE USE.



Refer to instruction manual



Wear eye protection



Wear protective clothing



Do not expose to rain



Use in a well ventilated area



Keep away from sparks and flame - battery could emit explosive gases



Corrosive substance



Warning!

1. SAFETY

1.1. GENERAL SAFETY

Modern vehicles contain extensive electronic systems. You are required to check with the vehicle manufacturer, for any specific instructions regarding the use of this type of equipment on each vehicle.

No liability will be accepted for damage/injury, where this product is not used in accordance with all instructions.

PLEASE SAVE THIS OWNER'S MANUAL AND READ BEFORE EACH USE.

- ✓ This manual will explain how to use the unit safely and effectively. Please read and follow these instructions and precautions carefully.
 - ✓ If someone else uses the Roadstart, make they are well informed on how to use it safely, and have read and understood the operating instructions. The longevity of the Roadstart depends on it.
 - ✓ Charge the Roadstart's internal battery immediately after purchase, after each use and as often as possible. It is highly recommended to leave the Roadstart permanently connected to the automatic charger.
 - ✓ Read the entire manual before using this product. Failure to do so could result in serious injury or death.
 - ✓ Keep out of reach of children.
 - ✓ This Roadstart is not intended for use by persons (including children) with reduced physical, sensory or mental capabilities, or lack of experience and knowledge, unless they have been given supervision or instruction concerning the use of the Roadstart by a person responsible for their safety.
 - ✓ This appliance can be used by children aged from 8 years and above and persons with reduced physical, sensory or mental capabilities or lack of experience and knowledge if they have been given supervision or instruction concerning use of the appliance in a safe way and understand the hazards involved.
 - ✓ Children shall not play with the appliance.
 - ✗ **DO NOT** put fingers or hands into the product.
 - ✗ **DO NOT** expose the Roadstart to rain or snow.
 - ✓ Use only recommended attachments. Use of an attachment not recommended or sold by Sealey may result in a risk of fire, electric shock or injury to persons or damage to property.
 - ✓ To reduce the risk of damage to the electric plug or cord, pull by the plug rather than the cord when disconnecting the Roadstart.
 - ✓ To reduce the risk of electric shock, unplug the Roadstart charger from the outlet before attempting any maintenance or cleaning. Simply turning off the controls will not reduce this risk.
 - ✗ **DO NOT** operate the Roadstart or charger with a damaged output cable; have the damaged part replaced immediately by a qualified service person.
 - ✓ If the supply cord is damaged, it must be replaced by the manufacturer, its service agent or similarly qualified persons in order to avoid a hazard.
 - ✗ NEVER wait until the Roadstart is completely discharged before recharging.
 - ✗ **DO NOT** operate the Roadstart if it has received a sharp blow, been dropped or otherwise damaged in any way; take it to a qualified service person.
 - ✗ **DO NOT** disassemble the Roadstart or charger; take it to a qualified service person when service or repair is required. Incorrect reassembly may result in a risk of fire or electric shock.
- RISK OF EXPLOSIVE GASES. PREVENT FLAMES AND SPARKS. PROVIDE ADEQUATE VENTILATION DURING CHARGING. WORKING IN THE VICINITY OF A LEAD-ACID BATTERY IS DANGEROUS. BATTERIES GENERATE EXPLOSIVE GASES DURING NORMAL OPERATION. FOR THIS REASON, IT IS IMPORTANT THAT YOU FOLLOW THESE INSTRUCTIONS EACH TIME YOU USE THE ROADSTART.**
- ✓ The Roadstart must be placed in a well-ventilated area.
 - ✓ To reduce the risk of a battery explosion, follow these instructions and those published by the battery manufacturer and the manufacturer of any equipment you intend to use in the vicinity of the battery. Review the cautionary markings on these products and on the engine.

1.2. PERSONAL PRECAUTIONS

RISK OF EXPLOSIVE GASES. A SPARK NEAR THE BATTERY MAY CAUSE A BATTERY EXPLOSION. TO REDUCE THE RISK OF A SPARK NEAR THE BATTERY:

- ✓ NEVER smoke or allow a spark or flame in the vicinity of a battery or engine.
- ✗ **DO NOT** permit the internal battery of the Roadstart to freeze. Never charge a frozen battery.
- ✓ When charging the internal battery, work in a well ventilated area and do not restrict the ventilation in any way.
- ✓ Be sure the area around the battery is well ventilated while the Roadstart is being used.

- ✓ Remove personal metal items such as rings, bracelets, necklaces and watches when working with a lead-acid battery. A lead-acid battery can produce a short-circuit current high enough to weld a ring or the like to metal, causing a severe burn.
- ✓ Be extra cautious, to reduce the risk of dropping a metal tool onto the battery. It might spark or short-circuit the battery or other electrical part that may cause an explosion.
- ✓ To prevent sparking, NEVER allow clamps to touch together or contact the same piece of metal.
- ✓ Consider having someone close enough by to come to your aid when you work near a lead-acid battery.
- ✓ Have plenty of fresh water and soap nearby in case battery acid contacts your skin, clothing or eyes.
- ✓ Wear complete eye and body protection, including safety goggles and protective clothing. Avoid touching your eyes while working near the battery.
- ✓ If battery acid contacts your skin or clothing, immediately wash the area with soap and water. If acid enters your eye, immediately flood the eye with cold running water for at least 10 minutes and get medical attention right away.
- ✓ If battery acid is accidentally swallowed, drink milk, the whites of eggs or water. **DO NOT** induce vomiting. Seek medical attention immediately.

2. INTRODUCTION

High performance (2x 23Ah PBIW4600, 2 x 32Ah PBIW6200) AGM battery, specially formulated to jump-start up to 1500hp diesel vehicles. Rotomolded high durability casing with lifetime warranty. Patented 4A microprocessor controlled speed charging and thermal runaway protection. Unlike other Roadstart packs, can be left safely on charge continuously. Audible warning signals if the unit has been turned on for too long without being connected to a battery and reverse polarity. Isolating rotary on/off switch and analogue display showing the internal battery level. 12V Output socket can be used as a memory saver as well as for powering accessories such as mini compressors. Ventilation system vents gases directly out of the casing via a 'Whistle' outlet, warning the user of a potential issue. A fuse integrated in the (+) clamp provides short-circuit and overload protection. Heavy-duty clamps with a braided link between each jaw for maximum power transmission. Curved clamps provide easier access to awkward battery terminals.

3. SPECIFICATION

Model no	PBIW4600	PBIW6200
Auxiliary output	1 x 12V	1 x 12V
Cable and clamp length	1.4m	1.4m
Peak amps	4600A (12V), 2300A (24V)	6200A (12V), 3100A (24V)
Starting current	1800A/900A	2400/1200A
Voltage	12/24V	12/24V

4. FEATURES

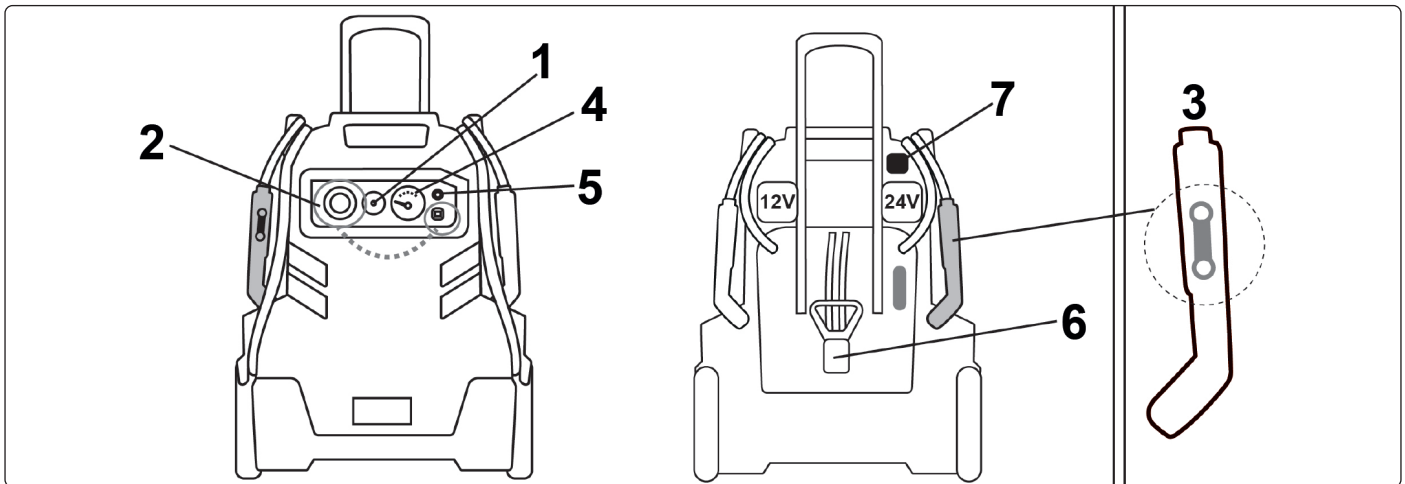

4.1. DESCRIPTION

1. Reverse polarity buzzer
2. 12V outlet, protected by 16A external circuit breaker
3. 500A fuse
4. Voltmeter
5. Push button for voltmeter
6. Voltage selector
7. Charger input plug

4.2. VOLTMETER

- 4.2.1. Press the button to show the charge level of the Roadstart.
- 4.2.2. Half an hour after disconnecting the charger from the Roadstart, the voltmeter must indicate about 13 volt for a full charge.

4.3. ALTERNATOR TESTING

- 4.3.1. After starting rev the engine to 2000 rpm, leave the Roadstart connected to the vehicle and press the voltmeter push button. The voltmeter must indicate between 14 and 14.4 volt if the alternator is functioning correctly.

4.4. RECHARGING, see Section 8 also.

4.4.1. NEVER wait until the Roadstart is completely discharged before recharging.

4.4.2. A fully automatic and intelligent charger AC 230V is provided with the Roadstart. Connect the charger to the mains AC 230V, then connect the charger to the Roadstart via the recharge plug. The Roadstart can be left permanently connected to the automatic charger, to maintain correct charge level.

5. PREPARATION FOR USE

❑ **WARNING!** Risk of contact with battery acid. Battery acid is a highly corrosive sulphuric acid.

5.1. Clean the battery terminals before using the Roadstart. During cleaning, keep airborne corrosion from coming into contact with your eyes, nose and mouth. Use baking soda and water to neutralize the battery acid and help eliminate airborne corrosion. **DO NOT** touch your eyes, nose or mouth.

5.2. Read, understand and follow all instructions for the Roadstart, battery, vehicle and any equipment used near the battery and the Roadstart.

5.3. Determine the voltage of the battery by referring to the vehicle owner's manual and make sure that the output voltage of the Roadstart is correct.

5.4. Make sure that the Roadstart cable clamps make tight connections.

5.5. CONNECTION TO A BATTERY

A SPARK NEAR THE BATTERY MAY CAUSE A BATTERY EXPLOSION. TO REDUCE THE RISK OF A SPARK NEAR THE BATTERY:

5.5.1. Attach the output cables to the battery and chassis as indicated below. Never allow the output clamps to touch each other.

5.5.2. Position the cables to reduce the risk of damage by the engine cover, door and moving or hot engine parts.

NOTE: If it is necessary to close the bonnet during the jump starting process, ensure that the bonnet does not touch the metal part of the battery clamps or cut the insulation of the cables.

5.5.3. Stay clear of fan blades, belts, pulleys and other parts that can cause injury.

5.5.4. Determine which post of the battery is grounded (connected) to the chassis. If the negative post is grounded to the chassis (as in most vehicles), see step 5.5. If the positive post is grounded to the chassis, see step 5.5.7.

5.5.5. For a negative-grounded vehicle, connect first the POSITIVE (RED) clamp from the Roadstart to the POSITIVE (POS, P, +) unearthed post of the battery. Then connect the NEGATIVE (BLACK) clamp to the vehicle chassis or engine block away from the battery. **DO NOT** connect the clamp to the carburettor, fuel lines or sheet-metal body parts. Connect to a heavy gauge metal part of the chassis frame or engine block.

5.5.6. When disconnecting the Roadstart, first remove the clamp from the vehicle chassis, then remove the clamp from the battery terminal, in that order.

5.5.7. In the rare event that the vehicle is positive-grounded, connect the NEGATIVE (BLACK) clamp from the Roadstart to the NEGATIVE (NEG, N, -) ungrounded post of the battery. Connect the POSITIVE (RED) clamp to the vehicle chassis or engine block away from the battery. **DO NOT** connect the clamp to the carburettor, fuel lines or sheet-metal body parts. Connect to a heavy gauge metal part of the frame or engine block.

6. OPERATION

6.1. TO START A VEHICLE

6.1.1. **THE VOLTAGE SELECTOR MUST BE DISCONNECTED !, FIG.1.**

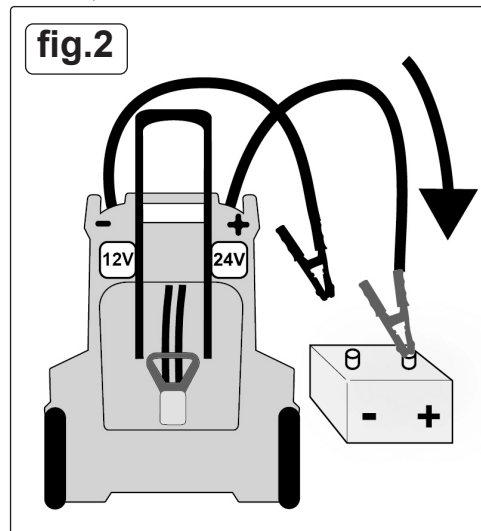
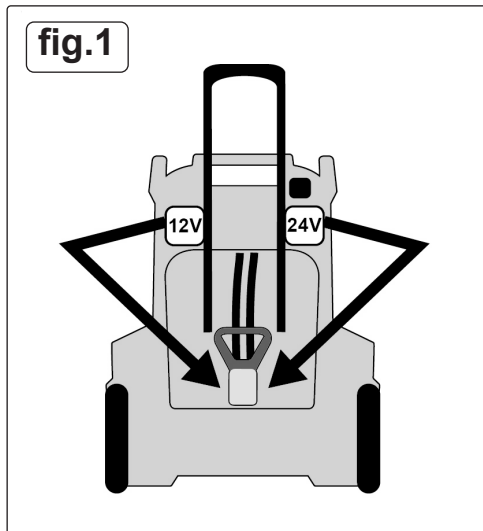

6.1.2. HOW TO CONNECT YOUR ROADSTART

IMPORTANT: Refer to section 6.8 risk of Explosion

6.1.2.1. **12V JUMP STARTING, fig.2**

Connect the red clamp (+) to the positive terminal (+) of the battery, then connect the Black clamp (-) to the negative terminal of the battery.

6.1.2.2. **24V JUMP STARTING**

NOTE: Read point 6.2 detection of 24V

IF THE BATTERIES ARE SIDE BY SIDE, fig.3

Connect the red clamp (+) to the positive terminal (+) of the battery, then connect the Black clamp (-) to the negative (-) terminal of the other battery.

IF THE BATTERIES ARE ON BOTH SIDES OF THE VEHICLE, fig.4

Connect the Red clamp (+) to the positive terminal (+) of the battery, then connect the black clamp (-) to the negative terminal (-) or to the mass of the vehicle.

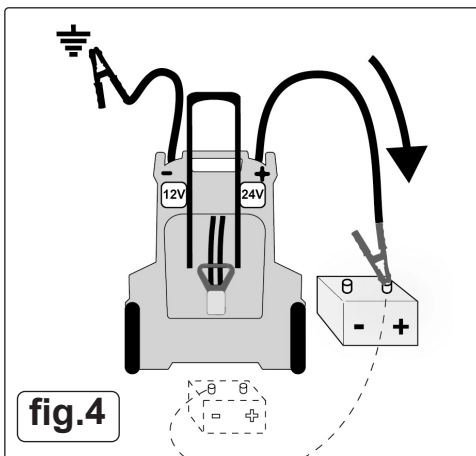
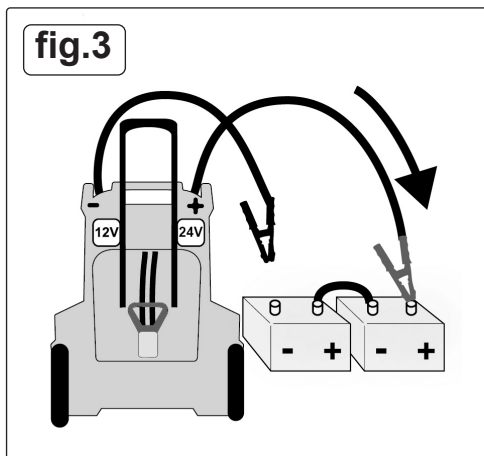

6.1.3. **VOLTAGE SELECTION, fig.5**

6.1.3.1. Select the correct voltage, for the vehicle to be jump started.

NOTE: From this moment on there is voltage to the clamps.

6.1.4. **START THE ENGINE**

6.1.4.1. Turn the ignition key for a maximum of 3 - 8 seconds. Wait for a further minute before attempting to start again.

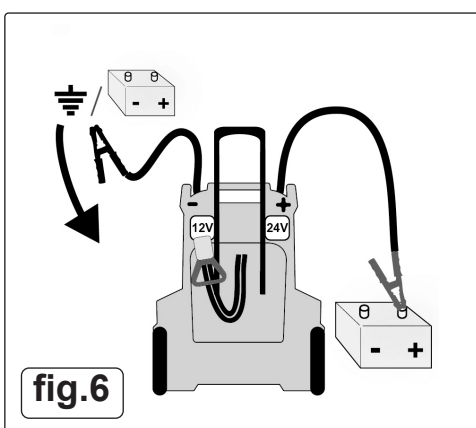
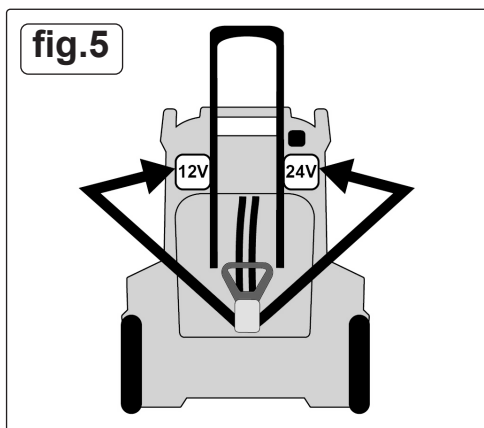

6.1.5. **DISCONNECTION, fig.6**

6.1.5.1. Disconnect the black (-) clamp first followed by the red (+) clamp.

6.1.6. **DISCONNECTION OF THE VOLTAGE SELECTOR, fig.7**

6.1.7. After starting disconnect the voltage selector.

6.1.8. **STORAGE, fig.7 see also Section 7**

6.1.9. Return the clamps to their support posts.

6.1.10. **RECHARGING, fig.8, see also Section 8**

6.1.10.1. Recharge the Roadstart immediately after use.

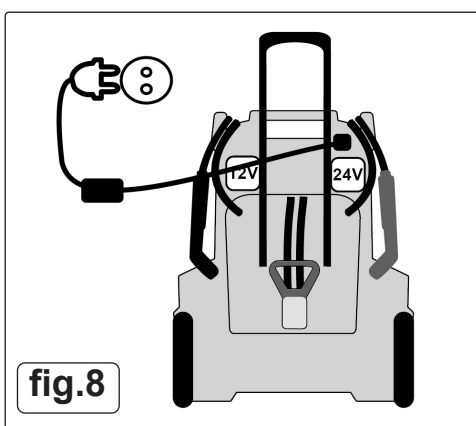
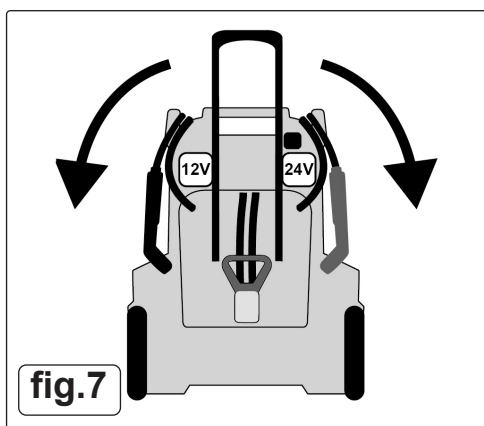

6.2. 24V VEHICLES - DETECTION OF 24V

6.2.1. Detection of 24 volt on a vehicle where the cables are not visible or where the batteries are located on both sides of the engine bay (large types of engines), is as follows, fig.9.

6.2.1.1. Use a voltmeter in position DC: connect the negative to the chassis of the vehicle and the positive to the positive post of a battery.

6.2.1.2. If the voltmeter indicates **12V**, you are **NOT** connected on the right battery.

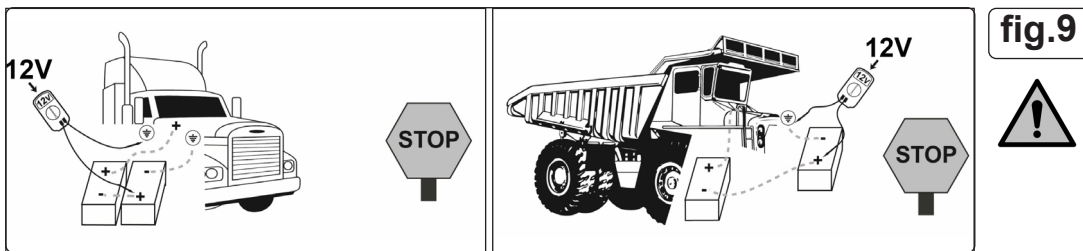

6.2.1.3. If the voltmeter meter indicates **24V** the correct battery has been selected, fig.10 and 10A. Connect the cargo booster clamps to the same points, observing correct polarity.

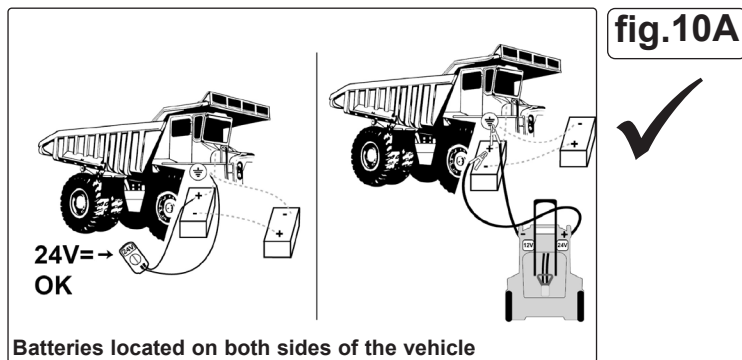
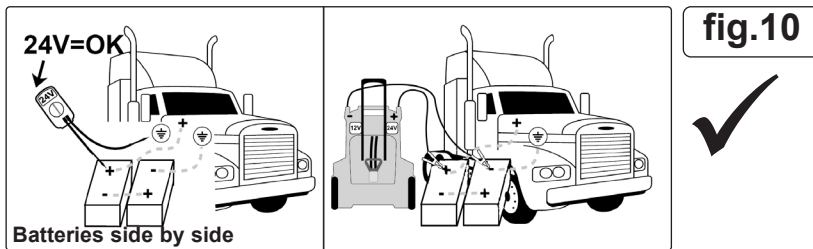

6.3. REVERSE POLARITY

6.3.1. If the polarity is reversed, the buzzer will give a warning signal under the following conditions:

- if the remaining voltage in the batteries of the vehicle, is at least 4v.
- if the voltage connector is not connected.

6.4. STARTING ATTEMPTS

× **DO NOT crank for more than 3-8 seconds, wait for a further 1 minute before making a second attempt.**

The reasons are:

1. To allow the voltage of the Roadstart to build up again.
2. To allow gasses inside the batteries to disperse.
3. To allow the batteries to cool down.

NOTE: If you do not wait and /or the starting attempt is too long, you risk losing power, performance is reduced by the second attempt and there is a risk of the fuse melting (blowing).

If after 3 attempts the engine does not start, it may be necessary to identify a further cause of the breakdown.

NOTE: if the Roadstart is fully charged and the starter turns slowly, the vehicle's battery or that of the Roadstart, may need to be inspected for a short circuit.

6.5. Never connect the Roadstart to a battery or a starter motor which is in short circuit.

6.6. Never disconnect the Roadstart whilst running the engine when there is no battery in the vehicle or when the vehicle's battery is at 0 volt. This may cause failure of the diodes in the alternator.

6.7. Never connect the Roadstart in short circuit, for example:

1. By connecting the red clamp (+) to the negative terminal of the battery and black clamp (-) to the vehicle's chassis, fig.11.

THE REVERSE POLARITY SIGNAL WILL NOT OPERATE BECAUSE THIS IS NOT A REVERSE POLARITY.

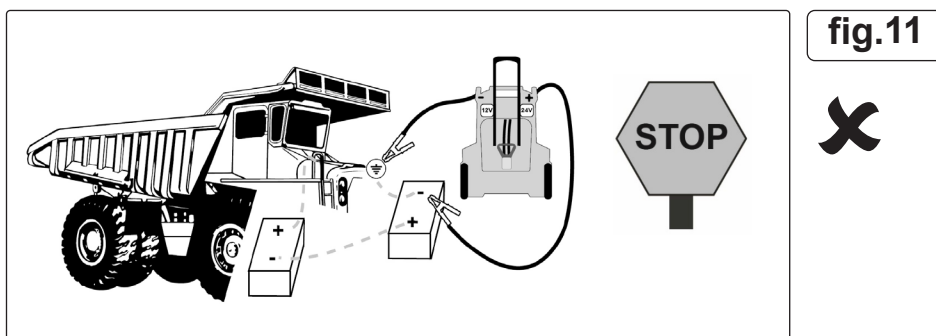

2. By connecting the clamps on the positive and negative terminal of the 2 batteries which are connected together in the 24V vehicle, fig.12.

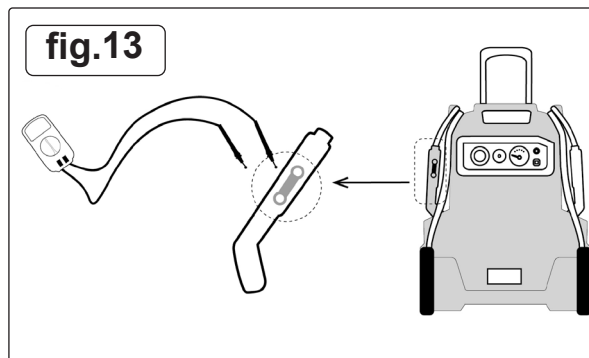
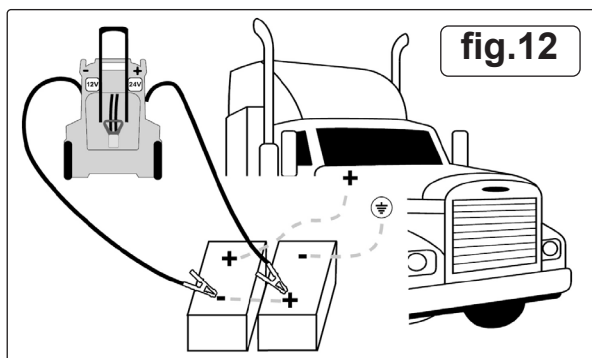

6.8. RISK OF EXPLOSION

- 6.8.1. Never connect the Roadstart on a 24V vehicle when you have selected the 12V voltage.
- 6.8.2. If this mistake is made, do not disconnect the voltage selector, because this may cause a spark. It is recommended to disconnect one of the clamps of the vehicle's battery, to move away from the Roadstart and to wait some minutes while the hydrogen escapes from the Roadstart. Contact supplier immediately.

6.9. PROTECTION, fig.13.

- 6.9.1. Roadstart is equipped with an internal 500A fuse located inside the positive clamp. It can blow following a short circuit or a too long starting attempt.
- 6.9.2. Test fuse with an external voltmeter if it is suspected that it has blown.

7. STORAGE

- 7.1. **Store the Roadstart in an upright position, inside, in a cool, dry, child free place.**
- 7.2. Always make sure the Roadstart is fully charged before storing. When not in use, it is highly recommended to leave the Roadstart on charge with its original charger.
 - × **DO NOT** use and/or store the Roadstart in or on any area or surface where damage could occur if the internal battery should unexpectedly leak acid.
- 7.3. Clamps must be stored on their support posts, ensuring they do not come into contact with any metallic surface.

8. RECHARGING

8.1. PREVENTING PREMATURE FAILURE OF THE BATTERIES

Note: Correct recharging of the batteries increases the Roadstart's efficiency and its lifespan.

- 8.1.1. The Roadstart must be put on permanent charge between use.
- 8.1.2. Never recharge the Roadstart 12/24V via the cigarette lighter plug of the Roadstart. The cigarette lighter plug (outlet 12V) is only connected to one battery and is just provided for the connection of a portable lamp 12V (maximum 16A) or all other 12V accessories.
- 8.1.3. Never completely discharge the Roadstart's batteries because:
 - The batteries do not have a memory effect.
 - Danger of irreversible sulphation.
- 8.1.4. During the charge, the clamps must never touch a metallic surface. One or several poles in the charging plug may melt.

8.2. CHARGER CONTROL PANEL fig.14

- 8.2.1. Press Start/Stop button to begin charging. If button is not pressed charging should begin in 10 minutes.
- 8.2.2. **Power LED (green) lit:** connected to mains supply.
- 8.2.3. **Charging LED (orange) lit:** Roadstart battery is charging.
- 8.2.4. **Charging LED (orange) flashing:** Roadstart battery is not charging because charger has detected a problem.
- 8.2.5. **Battery defect LED (red) will also light:**

Reasons:

1. Battery voltage below 10V after 2 hours of charging - battery may be defective. Make sure there are no loads on the battery, if there are remove them. If there are no loads have the battery checked or replaced. Desulphation unsuccessful - Battery may be defective have battery checked or replaced.
2. Battery is sulphated - Charger is in desulphation mode. Continue charging for 24 hours. If not successful have battery checked or replaced. Lack of progress is detected and battery voltage is below 14.2V. The battery may be overheated. If so allow to cool down. Have battery checked or replaced.

Battery voltage drops to below 12.2V in Maintain Mode. The battery will not hold a charge.

May be caused by a drain on the battery or the battery could be bad. Make sure there are no loads on the battery. If there are remove them. If not have the battery checked or replaced.

- 8.2.6. **Charged/Maintaining LED (green) pulsing:** The Roadstart battery is fully charged. The charger moves into float charging mode to maintain the battery capacity.
- 8.2.7. **Reverse polarity LED (red) flashing:** not applicable as Roadstart has a charging plug.

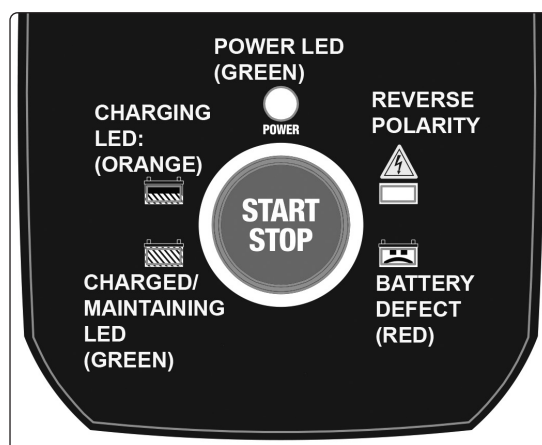

fig.14

9. TROUBLESHOOTING

PROBLEM	POSSIBLE CAUSE	REASON/SOLUTION
The Roadstart won't jump start car.	Clamps are not making a good connection to the battery. The Roadstart battery is not charged. The vehicle's battery is defective. The fuse has blown.	Check for poor connection to battery and chassis. Make sure connection points are clean. Rock clamps back and forth for a better connection. Check the battery charge status by pressing the button on the front of the Roadstart. Have the battery checked. Replace the power fuse.
Roadstart will not power 12V device.	The 12V device is not turned on. The 16A fuse has been triggered. Roadstart battery is not charged.	Turn on the 12V device. Push the 16A fuse button to turn it back on, see 4.1 point 2. Check the battery charge status by pressing the button on the front of the Roadstart.
The battery in the Roadstart won't hold a charge.	The battery is bad (will not accept a charge).	Have the battery checked.
The green POWER LED does not light when charger is properly connected.	Mains outlet dead. Poor electrical connection.	Check for open fuse or circuit breaker at the supplying AC outlet. Check power cord and extension cord for a loose fitting plug.
The red BATTERY DEFECT LED is lit and yellow/orange CHARGING LED is flashing rapidly.	The battery voltage is still under 10V after 2 hours of charging. (or) In maintain mode, the output current is more than 1.5A for 12 hours. Desulphation was unsuccessful.	The battery may be defective. Make sure there are no loads on the battery. If there are, remove them. If there are none, have the battery checked or replaced. The battery may be defective. Have it checked or replaced.



ENVIRONMENT PROTECTION

Recycle unwanted materials instead of disposing of them as waste. All tools, accessories and packaging should be sorted, taken to a recycling centre and disposed of in a manner which is compatible with the environment. When the product becomes completely unserviceable and requires disposal, drain any fluids (if applicable) into approved containers and dispose of the product and fluids according to local regulations.



WEEE REGULATIONS

Dispose of this product at the end of its working life in compliance with the EU Directive on Waste Electrical and Electronic Equipment (WEEE). When the product is no longer required, it must be disposed of in an environmentally protective way. Contact your local solid waste authority for recycling information.



BATTERY REMOVAL

Under the Waste Batteries and Accumulators Regulations 2009, Jack Sealey Ltd are required to inform potential purchasers of products containing batteries (as defined within these regulations), that they are registered with Valpak's registered compliance scheme. Jack Sealey Ltd Batteries Producer Registration Number (BPRN) is BPRN00705.

Note: It is our policy to continually improve products and as such we reserve the right to alter data, specifications and component parts without prior notice.

Important: No Liability is accepted for incorrect use of this product.

Warranty: Guarantee is 24 months from purchase date, proof of which is required for any claim.

Sealey Group, Kempson Way, Suffolk Business Park, Bury St Edmunds, Suffolk. IP32 7AR



01284 757500



01284 703534



sales@sealey.co.uk



www.sealey.co.uk