

Thank you for purchasing a National Machinery product. Manufactured to a high standard this product will, if used according to these instructions and properly maintained, give you years of trouble free performance.

IMPORTANT, BEFORE USING THE GRINDER PLEASE READ THESE INSTRUCTIONS CAREFULLY. NOTE THE SAFE OPERATIONAL REQUIREMENTS, WARNINGS AND CAUTIONS. USE THIS PRODUCT CORRECTLY AND WITH CARE, FOR THE PURPOSE FOR WHICH IT IS INTENDED. FAILURE TO DO SO MAY CAUSE DAMAGE AND/OR PERSONAL INJURY AND WILL INVALIDATE THE WARRANTY.

1. SAFETY INSTRUCTIONS

1.1. ELECTRICAL SAFETY.

WARNING! It is the responsibility of the user to read, understand and comply with the following:

You must check all electrical equipment and appliances to ensure they are safe before using. You must inspect power supply leads, plugs and all electrical connections for wear and damage. You must ensure the risk of electric shock is minimised by the installation of appropriate safety devices. An RCCB (Residual Current Circuit Breaker) should be incorporated in the main distribution board. We also recommend that an RCD (Residual Current Device) is used with all electrical products. It is particularly important to use an RCD with portable products that are plugged into an electrical supply not protected by an RCCB. If in doubt consult a qualified electrician. You may obtain a Residual Current Device by contacting your dealer. **You must** also read and understand the following instructions concerning electrical safety.

- 1.1.1. The **Electricity At Work Act 1989** requires all portable electrical appliances, if used on business premises, to be tested by a qualified electrician, using a Portable Appliance Tester (PAT), at least once a year.
- 1.1.2. The **Health & Safety at Work Act 1974** makes owners of electrical appliances responsible for the safe condition of the appliance and the safety of the appliance operator. **If in any doubt about electrical safety, contact a qualified electrician.**
- 1.1.3. Ensure the insulation on all cables and the product itself is safe before connecting to the mains power supply. See 1.1.1. & 1.1.2. above and use a Portable Appliance Tester (PAT).
- 1.1.4. Ensure that cables are always protected against short circuit and overload.
- 1.1.5. Regularly inspect power supply, leads and plugs for wear and damage and all electrical connections especially power connections, to ensure that none is loose.
- 1.1.6. **Important:** Ensure the voltage marked on the product is the same as the electrical power supply to be used and check that plugs are fitted with the correct capacity fuse. A 13 amp plug may require a fuse smaller than 13 amps for certain products (*subject to 1.1.10. below*) see fuse rating at right.
- 1.1.7. DO NOT pull or carry the powered appliance by its power supply lead.
- 1.1.8. DO NOT pull power plugs from sockets by the power cable.
- 1.1.9. DO NOT use worn or damaged leads, plugs or connections. Immediately replace or have repaired by a qualified electrician. A U.K. 3 pin plug with ASTA/BS approval is fitted. In case of damage, cut off and fit a new plug according to the following instructions (discard old plug safely).

(UK only - see diagram at right). **Ensure the unit is correctly earthed via a three-pin plug.**

- a) **Connect the GREEN/YELLOW earth wire to the earth terminal 'E'.**
- b) **Connect the BROWN live wire to live terminal 'L'.**
- c) **Connect the BLUE neutral wire to the neutral terminal 'N'.**

After wiring, check there are no bare wires, that all wires have been correctly connected, that the outer cable insulation extends beyond the cable restraint and that the restraint is tight.

Double insulated products are often fitted with live (BROWN) and neutral (BLUE) wires only. Double insulated products are always marked with this symbol . **To re-wire, connect the brown & blue wires as indicated above. DO NOT connect the brown or blue to the earth terminal.**

- 1.1.10. Some products require more than a 13 amp electrical supply. In such a case, NO plug will be fitted. **You must** contact a qualified electrician to ensure a 30 amp fused supply is available. We recommend you discuss the installation of an industrial round pin plug and socket with your electrician.
- 1.1.11. **Cable extension reels.** When a cable extension reel is used it should be fully unwound before connection. A cable reel with an RCD fitted is recommended since any product which is plugged into the cable reel will be protected. The section of the cores of the cable is important. We suggest 1.5mm² section cable as a minimum, but to be absolutely sure that the capacity of the cable reel is suitable for this product and for others that may be used in the other output sockets, we recommend the use of 2.5mm² section cable.

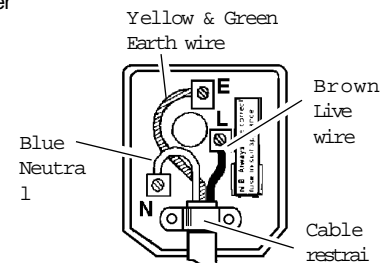

FUSE RATING

THIS PRODUCT MUST BE FITTED
WITH A
5 AMP FUSE

1.2 GENERAL SAFETY

- WARNING!** Disconnect the grinder from the mains power, and ensure the grinding wheels are at a standstill before attempting to change accessories, service or perform any maintenance.
- Maintain the grinder in good condition and check moving parts alignment regularly.
- Replace or repair damaged parts. Use recommended parts only. Non-authorized parts may be dangerous and will invalidate the warranty.
- DANGER! DO NOT use a damaged wheel as it is dangerous and may cause damage and/or serious personal injury.**
- WARNING! Only persons qualified under the "Abrasive Wheels Regulations" and holding a current grinding wheel certificate are to change or dress grinding wheels. Unplug grinder from mains power and refer to Section 4 "Grinding Wheels" for details.**
- WARNING!** Keep all guards and holding screws in place, tight and in good working order. Check regularly for damaged parts. A guard or any other part that is damaged should be repaired or replaced before tool is next used. The eye shields are a mandatory fitting when grinder is used in premises covered by the Health & Safety at Work Act.
- Locate grinder in a suitable working area, keep area clean, tidy and free from unrelated materials. Ensure adequate lighting.
- Before each use check grinding wheels for condition. If worn or damaged replace immediately.
- WARNING!** Always wear approved eye or face protection when operating the grinder.
- Use breathing protection in accordance with COSHH regulations if fumes or dust pose a hazard. Wear ear defenders and gloves if necessary.
- Maintain correct balance and footing. Ensure the floor is not slippery and wear non-slip shoes.
- Remove ill fitting clothing. Remove ties, watches, rings and other loose jewellery and contain and/or tie back long hair.
- Keep children and unauthorised persons away from the working area.
- DO NOT** use the grinder for a task it is not designed to perform.
- DO NOT** operate the grinder if any parts are damaged or missing as this may cause failure and/or personal injury.
- WARNING! DO NOT** grind any materials containing asbestos.
- DO NOT** switch on the grinder whilst the wheel is in contact with the workpiece.

- 7 **DO NOT** get the grinder wet or use in damp or wet locations or areas where there is condensation.
- 7 **DO NOT** use grinder where there are flammable liquids, solids or gases, such as paint solvents and including waste wiping or cleaning rags etc.
- 7 **DO NOT** touch the workpiece close to the ground surface as it will be very hot. Allow to cool. The workpiece may also be very sharp.
- 7 **DO NOT** operate the grinder when you are tired, under the influence of alcohol, drugs or intoxicating medication.
- 7 **DO NOT** leave the grinder operating unattended.
- 3 When not in use switch off the grinder, disconnect from the mains power supply and clean the machine and working area.

2. INTRODUCTION & SPECIFICATION

The NBG150 is suitable for workshop use. Fitted with wheel guards, adjustable eyeshields and tool rests the grinder is supplied with fine and coarse grade grinding wheels.

Motor150W/230V	Grinding Wheel Rating>3000rpm
No Load Speed2950rpm	Grinding Wheel Size150 x 16 x 12.7mm

3. ASSEMBLY & INSTALLATION

- 3.1. Unpack the product and check contents against the list below. Should there be any damaged or missing parts contact your supplier immediately.
- | | |
|---------------------|---------------------------------|
| 1. Grinder | 2. Eye Shield Support Plate x 2 |
| 3. Eyeshield x 2 | 4. Right & Left Hand Tool Rests |
| 5. Screws & Washers | |

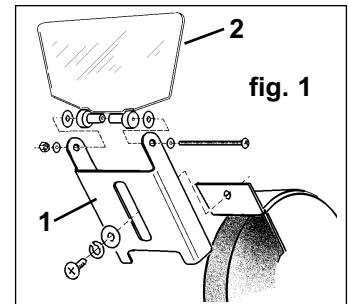

WARNING! Before assembly check to ensure grinder is unplugged from mains.

3.2. Eyeshield.

- 3.2.1. Attach eye shield support plates (fig.1.1) to the grinding wheel covers with screws and washers.
 3.2.2. Fit eye shields (fig.1.2) to support plates with screws, nuts and washers as shown.

3.3. Tool Rest.

- 3.3.1. Take tool rest (fig 2.1) and align it with bolt holes on the inside of the grinding wheel cover.
 3.3.2. Secure rest with bolts and washers as shown, ensuring gap between wheel and rest is a maximum of 2mm.
 3.3.3. When both rests have been fitted turn the grinding wheels by hand to confirm clearance.

3.4. Installation.

- 3.4.1. The grinder should be mounted on a firm, fireproof surface.
 3.4.2. The grinder is supplied with suction feet but may also be bolted or screwed to the work bench using the base holes provided.

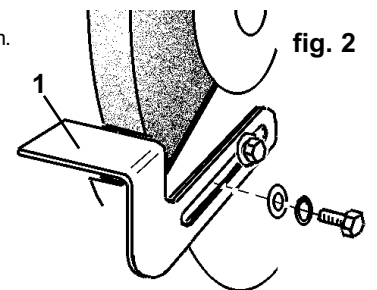

4. GRINDING WHEELS

4.1. MANDATORY SAFETY INSTRUCTIONS. (The following instructions must be observed together with those in Section 1).

- DANGER!** Use of a damaged wheel (stone) is dangerous and may cause damage and/or personal injury.
WARNING! Ensure grinder is unplugged from mains supply before attempting to change grinding wheel (stone). Only persons qualified under the "Abrasive Wheels Regulations" and holding a current grinding wheel certificate are authorised to change and dress grinding wheels (stones).
 Grinding wheels used with this machine must be of an adequate speed rating and suitable for the material to be ground. Ensure the maximum speed specification of the wheel is higher than that indicated on the machine data plate.
 Check that grinding wheels are secure and that wheels are not worn or damaged, that there are no fissures or cracks. If damaged replace immediately.
 Ensure replacement wheel is not damaged in any way such as cracks, deformations or splinters etc.. Also check the mounting flanges for deformation, burrs or chips. Damaged flanges must **NOT** be used as they may produce high stresses in the wheel causing it to break.
DO NOT over tighten a wheel. Never tamper with a wheel in order to adapt it to different size shaft.
 Install a new wheel as in 4.2. Once mounted on the grinder test the wheel before use by facing the grinder in a safe direction (point it away from yourself, others and vulnerable items) and run for a short time. Dress the wheel if necessary.

4.2. Wheel Changing Procedure. **WARNING!** Unplug grinder from the mains power supply before changing wheel.

- 4.2.1. Remove the eye shield support plate and loosen and pull the tool rest out as far as possible.
 4.2.2. Remove the three screws from the side of the wheel cover and remove the cover.
 4.2.3. Hold grinding wheel firmly - protect your hands with a cloth, or wear gloves. Unscrew retaining nut (fig.3.1).
Note: The nut on the right side of the grinder has standard right hand thread (undo anti-clockwise). The left side nut has a left hand thread and must be loosened by turning clockwise. It may be necessary to strike the wrench sharply in the loosening direction, with a soft-faced hammer, to loosen the nut.
 4.2.4. Remove grinding wheel washer (fig.3.2), blotter (3), wheel (4), 2nd blotter (5) and washer (6) from main spindle (7).
 4.2.5. Carefully inspect the new wheel before installing to ensure there are no fissures, chips, or cracks.

WARNING! DO NOT USE A DAMAGED WHEEL.

- 4.2.6. Inspect the blotters - if they are damaged, replace them. The grinder must never be used without wheel blotters. If none is available when needed, cut the same shape from a piece of suitable cardboard, for temporary use only.

- 4.2.7. Install the new wheel by reversing steps above. **Ensure washers (2 & 6) are installed correctly with the concave side against the blotter.**

- 4.2.8. Hold wheel steady and secure locking nut. **DO NOT** over tighten as this may crack the wheel.
 4.2.9. Replace wheel cover, replace eye shield, re-adjust tool rest to not more than 2mm from wheel and tighten securely.

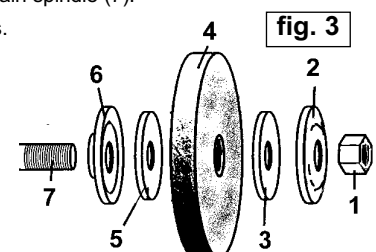

5. OPERATING INSTRUCTIONS

5.1. Pre-use Inspection.

WARNING! INSPECT THE GRINDER BEFORE USE. ENSURE THE GRINDER IS UNPLUGGED FROM THE MAINS POWER BEFORE COMMENCING THE INSPECTION.

- 5.1.1. Check the tool rests are securely fixed and are not more than 2mm from the grinding wheels.
- 5.1.2. Check that eye shields are in good condition, are secure and that you can see through them clearly.
- 5.1.3. Turn the grinding wheels by hand and check for any damage. Check they do not touch the tool rests and are correctly aligned. If any of the above checks fail, replace, repair, or adjust as necessary before starting the grinder.

5.2. Wheel Use.

The grinder is supplied with two aluminium oxide wheels, one coarse and one fine. Fine is preferred for hard materials and coarse for soft materials. If the surface of the wheel becomes "loaded" (coated with particles of the material being ground) it is probably the wrong grade for the job. **Important reminder:** Only a person holding a grinding wheel certificate may install wheels. See Section 4.

5.3. Using the Grinder.

WARNING! Before commencing work, ensure you read, understand and apply the Section 1 Safety Instructions.

- 5.3.1. Plug grinder into the mains power supply.
- 5.3.2. Adjust the eyeshield to give maximum protection.
- 5.3.3. Switch on the grinder and bring the workpiece slowly into contact with the rotating wheel.
- 5.3.4. When the task is complete unplug the grinder from the mains power supply and clean the machine ready for next use.

6. MAINTENANCE

WARNING! Ensure the grinder is unplugged from the mains power supply before performing any maintenance or service.

- 6.1. As the grinding wheels wear, adjust the positions of the tool rests. Each rest must be set not more than 2mm from the grinding surface.
- 6.2. Regularly remove the grinding wheel covers and clean out any dust and dirt.
- 6.3. The machine motor and bearings are sealed units and require no regular maintenance. Should you require assistance, contact your local service agent.

Declaration of Conformity We, the sole importer into the UK, declare that the product listed below is in conformity with the following standards and directives.

Bench Grinder Model NBG150

73/23/EEC Low Voltage Directive
89/336/EEC EMC Directive
98/37/EC Machinery Directive
93/68/EEC CE Marking Directive



The construction file for this product is held by the Manufacturer.

Signature

Date: 1st December 1999

For National Machinery Ltd.



WARRANTY: GUARANTEE IS 12 MONTHS PARTS AND LABOUR FROM PURCHASE DATE. PROOF OF PURCHASE WILL BE REQUIRED FOR ANY CLAIM.