



# 250AMP PROFESSIONAL GAS/NO-GAS MIG WELDER WITH EURO TORCH

MODEL NO: MIGHTYMIG250.V3

Thank you for purchasing a Sealey product. Manufactured to a high standard, this product will, if used according to these instructions, and properly maintained, give you years of trouble free performance.

**IMPORTANT:** PLEASE READ THESE INSTRUCTIONS CAREFULLY. NOTE THE SAFE OPERATIONAL REQUIREMENTS, WARNINGS & CAUTIONS. USE THE PRODUCT CORRECTLY AND WITH CARE FOR THE PURPOSE FOR WHICH IT IS INTENDED. FAILURE TO DO SO MAY CAUSE DAMAGE AND/OR PERSONAL INJURY AND WILL INVALIDATE THE WARRANTY. KEEP THESE INSTRUCTIONS SAFE FOR FUTURE USE.



Refer to instructions



Wear a welding mask



Wear protective gloves



Electrical shock hazard



Warning: Avoid damp / wet



Caution required



Arc rays can burn eyes and injure skin.



Electric shock from welding electrodes can kill.



Breathing welding fumes can be hazardous to your health.



Electromagnetic fields can cause pacemaker malfunction.



Welding sparks can cause explosions or fire.

## 1. SAFETY

### 1.1. ELECTRICAL SAFETY

- WARNING!** It is the user's responsibility to check the following:
- ✓ Check all electrical equipment and appliances to ensure that they are safe before using. Inspect power supply leads, plugs and all electrical connections for wear and damage. Sealey recommend that an RCD (Residual Current Device) is used with all electrical products.
- Electrical safety information.** It is important that the following information is read and understood:
- ✓ Ensure that the insulation on all cables and on the appliance is safe before connecting it to the power supply.
- ✓ Regularly inspect power supply cables and plugs for wear or damage and check all connections to ensure that they are secure.
- Important:** Ensure that the voltage rating on the appliance suits the power supply to be used and that the plug is fitted with the correct fuse.
- ✗ **DO NOT** pull or carry the appliance by the power cable.
- ✗ **DO NOT** pull the plug from the socket by the cable.
- ✗ **DO NOT** use worn or damaged cables, plugs or connectors. Ensure that any faulty item is repaired or is replaced immediately by a qualified electrician.

If the cable or plug is damaged during use, switch off the electricity supply and remove from use.

**Ensure that repairs are carried out by a qualified electrician.**

### 1.2. GENERAL SAFETY

- ▲ **DANGER!** Unplug the welder from the mains power supply before performing maintenance or service.
- ✓ Keep the welder and cables in good condition. Take immediate action to repair or replace damaged parts.
- ✓ Use genuine parts and accessories only. Unapproved parts may be dangerous and will invalidate the warranty.
- ✓ Use an air hose to regularly blow out any dirt from the liner and keep the welder clean for best and safest performance.
- ✓ Check and spray the gas cup and contact tip regularly with anti-spatter spray which is available from your Sealey stockist.
- ✓ Locate the welder in a suitable work area. Ensure that the area has adequate ventilation as welding fumes are harmful.
- ✓ Keep work area clean, tidy and free from unrelated materials. Also ensure that the work area has adequate lighting and that a fire extinguisher is at hand.
- WARNING!** Use welding head shield to protect eyes and avoid exposing skin to ultraviolet rays given off by electric arc. **Wear safety welding gauntlets.**
- ✓ Remove ill fitting clothing, remove ties, watches, rings and other loose jewellery and contain long hair.
- ✓ Ensure that the workpiece is correctly secured before operating the welder.
- ✓ Avoid unintentional contact with workpiece. Accidental or uncontrolled use of the torch may be dangerous and will wear the nozzle.
- ✓ Keep unauthorised persons away from the work area. Any persons working within the area must wear protective head shield and gloves.
- ✓ Operators must receive adequate training before using the welder.
- ✓ Stand correctly, keeping a good footing and balance, and ensure that the floor is not slippery. Wear non-slip shoes.
- ✓ Turn mains power switch to **OFF** when welder is not in use.
- ✗ **DO NOT** operate the welder if it or its cables are damaged and **DO NOT** attempt to fit any unapproved torch or other parts to the unit.
- ✗ **DO NOT** get welder wet or use in damp or wet locations or areas where there is condensation.
- ▲ **DANGER! DO NOT weld near inflammable materials, solids, liquids, or gases, and DO NOT weld containers or pipes which have held flammable materials or gases, liquids or solids. Avoid operating on materials cleaned with chlorinated solvents or near such solvents.**
- WARNING! DO NOT** use for pipe thawing.
- ✓ Ensure the welder is positioned on a level surface to avoid toppling over.
- ✗ **DO NOT** stand welder on a metal workbench, car bodywork or similar object.
- ✗ **DO NOT** touch any live metal parts of the torch or electrode while the machine is switched on.

- ✗ **DO NOT** pull the welder by the cable or the torch and **DO NOT** bend or strain cables. Protect cables from sharp or abrasive items and
- ✗ **DO NOT** stand on them. Protect from heat. Long lengths of slack must be gathered and neatly coiled. **DO NOT** place cables where they could endanger other people.
- ✗ **DO NOT** touch the torch or workpiece immediately after welding as they will be very hot. Allow to cool.
- ✗ **DO NOT** operate welder while under the influence of drugs, alcohol or intoxicating medication, or if tired.
- ✓ When not in use store the welder in a safe, dry, childproof area.
- ✗ Welding power sources are not suitable for use in rain or snow.
- ✓ The output is rated at an ambient temperature of 20°C and the welding time may be reduced at higher temperatures.

### 1.3. GAS SAFETY

- ✓ Store gas cylinders in a vertical position only and ensure that the storage area is correctly secured.
- ✗ **DO NOT** store gas cylinders in areas where temperature exceeds 50°C. **DO NOT** use direct heat on a cylinder. Always keep gas cylinders cool.
- ✗ **DO NOT** attempt to repair or modify any part of a gas cylinder or valve and **DO NOT** puncture or damage a cylinder.
- ✗ **DO NOT** obscure or remove any official cylinder labels. Always check the gas identity before use. Avoid getting gas cylinders oily or greasy.
- ✗ **DO NOT** lift a cylinder by the cap, guard or valve. Always keep caps and guards in place and close valve when not in use.
- ✗ **Risk of electric shock:** Electric shock from welding electrode can kill. **DO NOT** weld in the rain or snow. Wear dry insulating gloves. **DO NOT** touch electrode with bare hands. **DO NOT** wear wet or damaged gloves. Protect yourself from electric shock by insulating yourself from workpiece. **DO NOT** open the equipment enclosure.
- ✓ **Risk induced by welding fumes:** Breathing welding fumes can be hazardous to your health. Keep your head out of the fumes. Use equipment in an open area. Use ventilating fan to remove fumes.
- ✗ **Risk induced by welding sparks:** Welding sparks can cause explosion or fire. Keep flammables away from welding. **DO NOT** weld near flammables. Welding sparks can cause fires. Have a fire extinguisher nearby and have a watchperson ready to use it. **DO NOT** weld on drums or any closed containers.
- ✓ **Risk induced by the arc:** Arc rays can burn eyes and injure skin. Wear hat and safety glasses. Use ear protection and button shirt collar. Use welding helmet with correct shade of filter. Wear complete body protection.
- ✗ **Risk induced by electromagnetic fields:** Welding current produces electromagnetic field. **DO NOT** use with medical implants. Never coil welding cables around your body. Route the welding cables together.

## 2. INTRODUCTION

Heavy-duty high output transformer and forced air cooling to maximize duty cycle performance. Supplied with a high quality BINZEL® MB25 Euro torch, 3m earth cable, 1.4m of gas hose, twin gauged gas regulator, 0.8 and 1mm tips. Set-up in the gas welding mode but can also easily be switched to gasless. Can be used with large, industrial CO2 gas bottles.

**IMPORTANT:** These instructions contain information you require to prepare your machine for welding, together with a maintenance and trouble shooting section. If you have no previous experience the instructions are not intended to show you how to become a welder. Should you have no experience, we recommend that you seek training from an expert source. MIG welding is relatively easy to perform, but does require a steady hand and time practising under supervision with scrap metal as it is only with continued practice that you will achieve the desired results.

## 3. SPECIFICATION

MODEL NO:	MIGHTYMIG250.V3
Absorbed Power:	11kW
Case Size:	Extra-Large
Consumables:	Nozzel (Pack of 2): MIG929 Tips 0.8mm (Pack of 5): MIG917 Tips 1mm (Pack of 5): TG100/2
Cooling System:	Forced Air
Duty Cycle:	100% @110A, 60% @140A, 15% @250A
EMC Classification	A
Gas Type:	CO2, Argon, CO2/Argon Mix
Supply:	230V-32A
Torch:	3m Euro Non-Live - BINZEL® MB25
Type of Shielding Gas	CO2, Argon, CO2/Argon Mix
Welding Current:	50-250A
Wire Capacity:	5-15kg



## 4. ASSEMBLY

- 4.1. **ASSEMBLING THE FRONT CASTORS:** (Refer to fig.1) The wheels are more easily assembled with the welder placed upside down on a smooth non-abrasive surface. The welder should be turned over by at least two people as it is very heavy.
  - 4.1.1. Bolt the two castors to the front end of the main casing using the bolts provided.
- 4.2. **ASSEMBLING THE BOTTOM PANEL & REAR WHEELS:** (Refer to fig.1)
  - 4.2.1. Place the bottom panel onto the underside of the main welder casing in the position indicated below so that the fixings on the bottom of the main casing show within the holes punched through the bottom panel. The underside of the main casing extends beyond the back of the casing by 5cm and has three threaded fixings within it. Align the 3 fixing holes across the width of the bottom panel with these threaded fixings and insert an M8 x 16mm bolt into each hole together with a flat washer and a locking washer. Leave finger tight.
  - 4.2.2. In the two returned flanges that lap over each side of the main casing are two holes which will align with threaded inserts in the sides of the main casing. Into each hole insert an M5 x 25mm slotted bolt together with a flat washer and a locking washer. Tighten all four fixings, then tighten the three bolts on the underside of the bottom panel.
  - 4.2.3. Put wheel onto each end of the axle followed by a washer. Fit cotter pin through each free end of axle and bend it over to retain the wheels.

- 4.2.4. With the assistance of another person turn the welder the right way up onto its wheels.
- 4.3. **ASSEMBLING THE HANDLE:** (Refer to fig.2) On the front of the welder there are two pairs of threaded inserts, one pair in the top left corner and one pair in the top right hand corner.
- 4.3.1. Attach the left hand handle mounting (1) to the front of the welder using two of the 25mm round headed bolts provided. **DO NOT** fully tighten yet.
- 4.3.2. Slide the handle tube (2) into the socket in the mounting and push fully home.
- 4.3.3. Slide the socket on the right hand handle mounting (3) over the free end of the handle tube and rotate the mounting downwards until it is resting on the front of the welder. Using two of the 25mm round headed bolts provided to fix the right hand mounting in place.
- 4.3.4. Now fully tighten all four fixings.

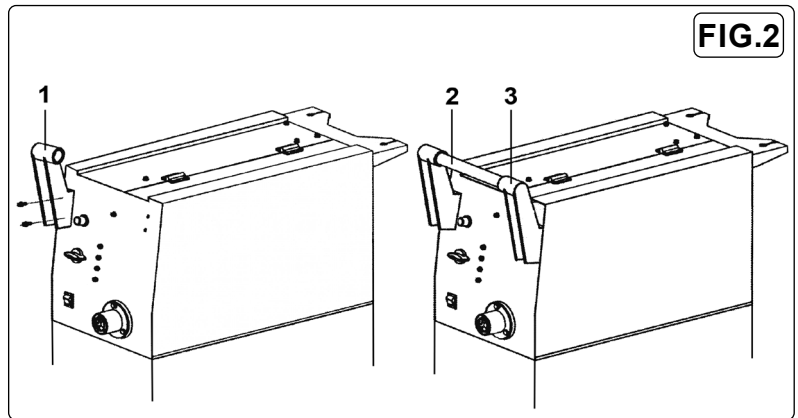
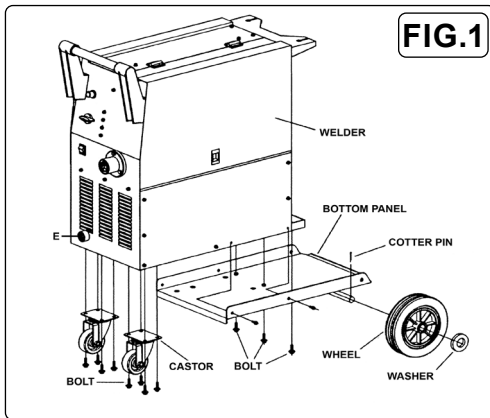

4.4. **ASSEMBLING THE EARTH CLAMP:** (Refer to fig.3)

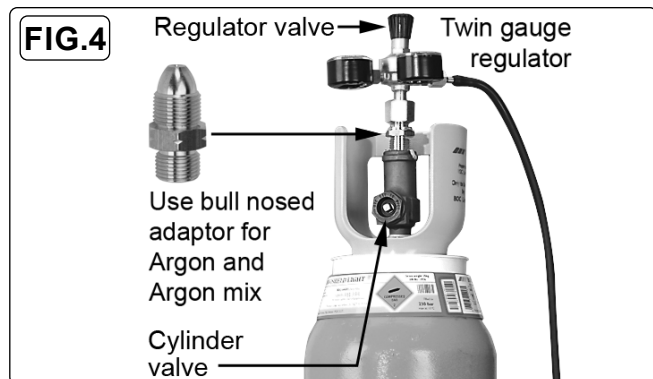
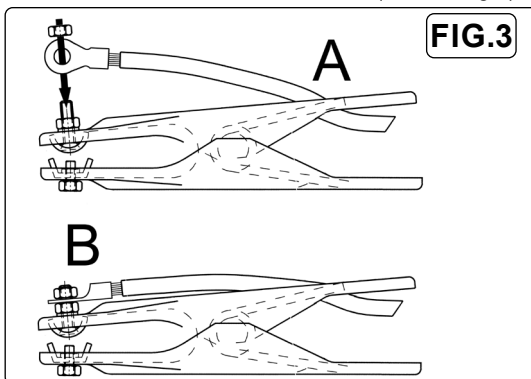

- 4.4.1. Feed the eyelet on the end of the earth lead through the hole in the clamp arm as shown in fig.3A.
- 4.4.2. Drop the eyelet over the terminal and firmly fix with the bolt provided as shown in fig.3B.
- 4.5. **INSTALLING THE GAS CYLINDER.** The welder is designed to accommodate small or medium sized gas cylinders up to a maximum height of 1000mm. Contact your local Gas dealer for supply.
- 4.5.1. Place the gas cylinder onto the rear platform of the welder. Drop one end of the fixing chain into one side of the retaining bracket. Draw the chain around the cylinder and place it into the slot on the other side of the bracket leaving as little slack in the chain as possible.
- 4.6. **ATTACHING THE REGULATOR (FIG.4).** Whichever gas you are using it is advisable to 'crack' the cylinder valve before attaching the regulator. This means opening and closing the valve very quickly in order to blow away any dust and dirt that may have accumulated in the gas outlet. Stand to one side whilst doing this.
- 4.6.1. **CO<sup>2</sup> GAS (FIG.4).** Ensure that the threads on the gas bottle are undamaged and free of oil and grease before attaching the regulator. (Oil or grease in the presence of high pressure gases can be explosive.) Ensure that the regulator has an undamaged gasket fitted. The regulator will screw directly to the threads on the gas bottle. Tighten with a spanner.
- 4.6.2. **ARGON GAS OR ARGON MIXTURES.** Cylinders containing Argon gas and Argon mixtures have a female thread and will require the use of a Bull Nose Adaptor to attach the regulator to the cylinder as indicated in fig.4. Ensure that the threads on the gas bottle are undamaged and free of oil and grease before attaching the regulator. (Oil or grease in the presence of high pressure gases is explosive.) Fit the Bull Nose Adaptor to the cylinder first and tighten with a spanner. Ensure that the regulator has an undamaged gasket before fitting onto the Bull Nose Adaptor. Tighten with a spanner.
- 4.6.3. Slide a worm drive hose clip over each end of the gas hose supplied. Push one end of the hose onto the regulator outlet and the other end over the gas inlet spigot on the back of the welder. Tighten the clips to ensure a good seal.
- 4.6.4. Close the regulator valve by turning it anticlockwise before opening the cylinder valve. Stand to one side when opening the cylinder valve.
- 4.6.5. Set the regulator flow rate to 5-8 litres/min depending on the material to be welded, and whether there are draughts which are strong enough to disturb the gas flow.
- 4.7. **CONNECT THE EARTHING CABLE TO THE WELDER** Take the dinse plug on the end of the earth clamp cable and insert it into the earthing socket in the bottom left hand corner of the welder front cover (see fig.1E) ensuring that the spigot on the plug enters the keyway in the socket. Fully insert the plug then turn it through 90° to lock it in place.

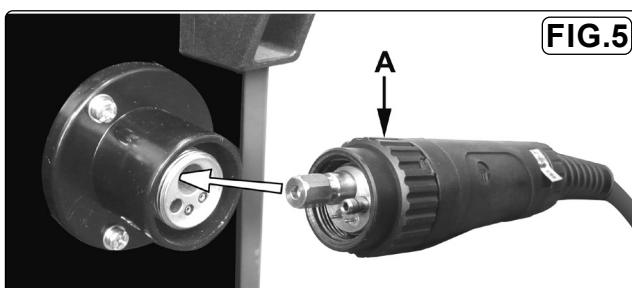

#### 4.8. CONNECT THE TORCH CABLE TO THE WELDER

- 4.8.1. Align the pins on the Euro connector with the socket on the welder front panel as shown in fig.5.
- 4.8.2. Push the connector into the socket and rotate the locking ring (A) clockwise so that it draws the plug into the socket as shown in fig.6.  
**NOTE:** damage to torches and cables is not covered by warranty.

#### 4.9. FITTING A 15KG REEL OF WIRE

- 4.9.1. MIGHTYMIG 250 will accept either a 5kg or a 15kg reel of wire.
- 4.9.2. Ensure that the wire diameter used, is matched by the correct groove size in the drive wheel and the correct tip size on the torch as well as the correct torch liner. Failure to do this could cause the wire to slip and/or bind.

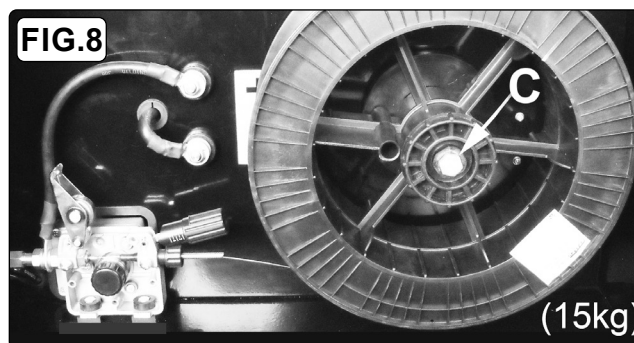
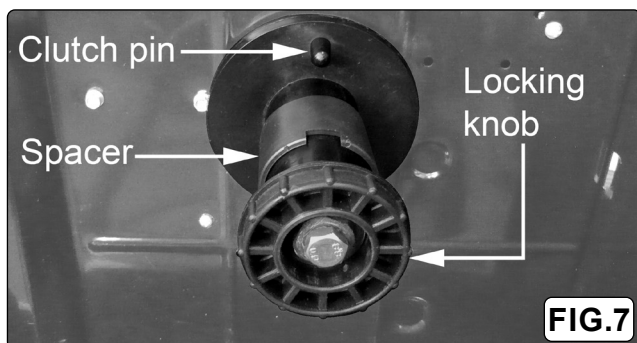

- 4.9.3. Unscrew the locking knob from the end of the spool holder (see fig.7) and remove the spacer. Slide the reel of wire onto the spool holder and ensure that the clutch pin at the back of the spool holder engages into the guide hole in the wire reel moulding. This will prevent the wire reel from freewheeling on the spool holder. When using a 5kg reel, slide the spacer onto the spool holder before refixing the locking knob. Ensure that the wire is coming off the bottom of the reel in the direction of the wire drive unit as shown in fig.8 which shows a 15kg reel of wire in place on the spool holder.

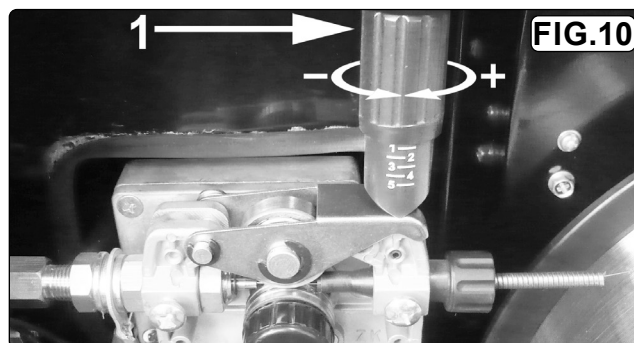
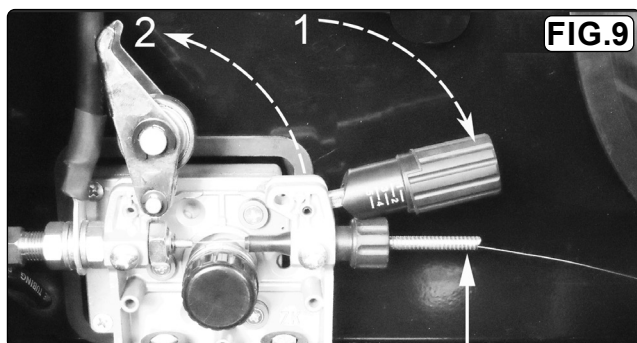

#### 4.10. FEED WIRE THROUGH TO TORCH

- 4.10.1. Referring to fig.9, open the wire feed mechanism by pushing the locking/wire tension knob (1) down to the right allowing the pressure roller carrier (2) to spring up revealing the feed roller.
  - 4.10.2. Ensure that the required feed groove (0.8 or 1.0) is in line with the wire path.
  - 4.10.3. See Section 4.13 on how to reverse or change the roller.
  - 4.10.4. Release the wire from the reel and cut off any bent portion ensuring that there are no burrs left on the end of the wire. Keep the wire under tension at all times to prevent it uncoiling.
  - 4.10.5. Straighten about 40-50mm of wire and gently push it through the flexible metal sheathed cable (3) and through the 0.8 or 1.0mm feed roller groove and on into the torch cable liner.
  - 4.10.6. Push down the pressure roller carrier onto the wire feed roller and hold it down. Lift up the locking/wire tension knob so that it enters the slot in the pressure roller carrier and snaps into the indent in its top surface. See fig.9. Rotate the tension knob to a medium setting i.e. between 2 and 3.
  - 4.10.7. Remove gas cup (fig.11-2) and contact tip (1) from end of torch as follows:
    - a) Take torch in left hand with the torch tip facing to the right.
    - b) Grasp gas cup firmly in your right hand.
    - c) Turn gas cup clockwise only and pull it off end of torch tip.
- WARNING! DO NOT** turn gas cup anti-clockwise, as this will damage the internal spring.
- d) Unscrew copper contact tip (right hand thread) to remove.

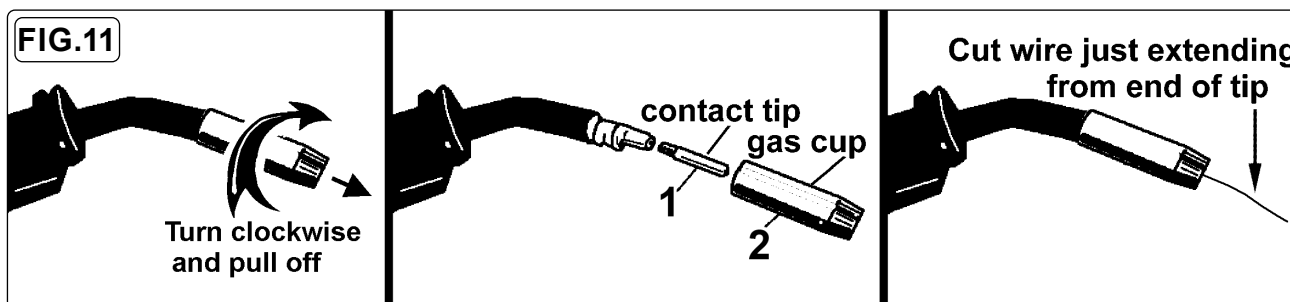

- 4.10.8. Check welder is switched off "0", and that the earth clamp is away from the torch tip. Connect the welder to the mains power supply and set the voltage switch to one.
- 4.10.9. Set the wire speed knob to position 5 or 6. Keep the torch cable as straight as possible and press the torch switch. The wire will feed through the torch.

- 4.10.10. When the wire has fed through, switch welder off, unplug from mains.
- Take torch in left hand, slide the contact tip over the wire and screw back into place.
  - Grasp gas cup in right hand, push onto torch head and turn clockwise only. **DO NOT** turn gas cup anti-clockwise, as this will damage the internal spring.
  - Cut wire so that it is just protruding from the cup.
- 4.11. SETTING WIRE TENSION**
- 4.11.1. Adjust the wire tension by rotating the wire tension knob.
- 4.11.2. Turn clockwise to increase the tension and anticlockwise to decrease the tension. See (1) in fig.10.
- IMPORTANT:** Too little or too much tension will cause problematic wire feed and result in poor welding.
- 4.11.3. Tension between rollers is checked by slowing down the wire between gloved fingers. If top feed roller skids the tension is correct. Use as low a tension as possible, too high a tension will disfigure wire and result in a blown fuse.
- 4.12. CLUTCH ADJUSTMENT.** Note: It is essential that the clutch is adjusted correctly.
- 4.12.1. Once the wire is fed through the torch, switch on the machine and set the wire speed to maximum.
- 4.12.2. Depress torch switch and release quickly. If the spool overruns it indicates that the clutch is too loose.
- 4.12.3. Tighten the clutch nut located in the centre of the wire spool holder with a spanner (fig.8-C) and test the machine as above until the wire stops over running.

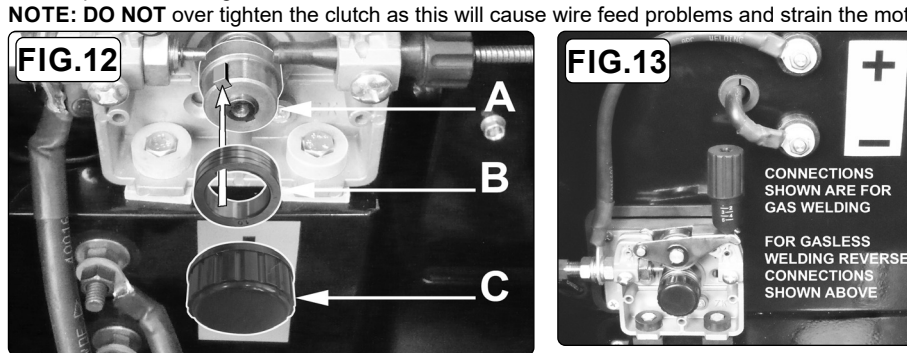

- 4.13. TURNING/CHANGING THE DRIVE ROLLER.** (See fig.12) Ensure that the wire diameter used, is matched by the correct groove size in the drive wheel and the correct tip size on the torch as well as the correct torch liner. Failure to do this could cause the wire to slip and/or bind.
- 4.13.1. Referring to fig.9, open the wire feed mechanism by pushing the locking/wire tension knob (1) down to the right allowing the pressure roller carrier (2) to spring up revealing the feed roller.
- 4.13.2. Referring to fig.12, loosen and unscrew the black feed roller retaining knob (C) and put to one side.
- 4.13.3. The roller carrier (A) is keyed to the main drive shaft and the drive roller (B) is keyed to the carrier, see below. Place a finger onto the end of the drive shaft to prevent the carrier moving and slide the drive roller off the carrier with your other hand.
- 4.13.4. The size of each wire feed groove is printed on the edge of the roller on the same side as the groove.
- 4.13.5. Turn the roller over to use the other groove or use a roller with different sized grooves as required. The groove to be used should be positioned furthest away from you to be in line with the drive path.
- 4.13.6. Check that the key in the carrier (A) is properly seated in its slot. Ensure that the slot on the inside face of the drive roller (B) is aligned with the key and slide the roller back onto the carrier.
- 4.13.7. Screw the black roller retaining knob (C) back on to the end of the drive shaft and tighten.
- 4.14. CONVERTING TO GASLESS WELDING.** When delivered, your welder is set up for gas welding (see fig.13) with the torch cable connected to the positive (+) terminal and the earthing cable connected to the negative (-) terminal.
- 4.14.1. To weld without gas (using flux cored wire) you must reverse the polarity and connect the torch cable to the negative (-) terminal and the earthing cable to the positive (+) terminal.**
- 4.14.2. Ensure that the machine is switched off and unplugged from the mains supply before carrying out this task.**
- 4.14.3. Safely disconnect the gas.
- 4.14.4. Fit a 1.0mm tip to the torch.
- 4.14.5. Change the drive roller to one having a 1.0mm groove.
- 4.14.6. Mount the flux cored wire reel and feed it through to the torch.

## 5. MIG/MAG WELDING

A spool of welding wire is positioned on the welder's spool holder and automatically fed through an insulated liner in the torch to the tip. The torch assembly consists of a switch, liner, gas hose, and control cable. The switch activates the wire feed roller and the gas flow. Conversely, releasing the switch stops the wire feed and gas flow. The weld current is transferred to the electrode (the wire) from the contact tip at the end of the torch. A gas cup fits over the contact tip to direct the gas flow towards the weld ensuring that the arc welding process is shielded from oxidising air contaminants. The shielding gas also assists heating of the weld materials. (The welder can also be used in gasless mode using flux cored wire). The torch is connected to the positive side of a DC rectifier, and the negative clamp is attached to the workpiece.

**IMPORTANT: Should you have no welding experience, we recommend you seek training from an expert source to ensure your personal health & safety. Good Mig welding may be achieved only with continued, supervised practice.**

### 5.1. PREPARATION FOR WELDING

**IMPORTANT: BEFORE YOU COMMENCE, MAKE SURE THE MACHINE IS SWITCHED OFF AT THE MAINS. IF WELDING A CAR, DISCONNECT THE BATTERY OR FIT AN ELECTRONIC CIRCUIT PROTECTOR. WE STRONGLY RECOMMEND THE USE OF SEALEY "PROSAF/12V OR 24V IN ORDER TO PROTECT SOPHISTICATED ELECTRONICS. ENSURE YOU HAVE READ & UNDERSTOOD THE ELECTRICAL SAFETY INSTRUCTIONS IN CHAPTER 1.**

#### 5.1.1. Connecting the Earth Lead.

To ensure a complete circuit, the earth lead must be securely attached to the work piece that is to be welded.

- Best connection is obtained by grinding clean the point of contact on the workpiece before connecting the earth clamp.
- The weld area must also be free of paint, rust, grease, etc.
- When welding a vehicle, be sure the vehicle battery is disconnected or fit an Electronic Circuit Protector available from your Sealey stockist.

#### 5.1.2. Power Output switch

Set the switch to position 1 or 2 for welding up to 2mm thickness. Use settings 3,4,5,6. for thicker welds.

#### 5.1.3. Setting the welder controls.

In principle, the lower the amperage required, the slower the wire speed. See setting chart for voltage and corresponding wire speeds (see fig.14). Note: these settings are only a guide and will vary according to the operator's experience.

- 5.1.4. **Welding mild steel.** To weld mild steel you can use CO<sup>2</sup> gas for most tasks where spatter and the high build up of weld do not pose a problem. Welding with a long arc reduces penetration and widens the arc. This in turn results in more spatter. A long welding arc can be appropriate for welding butt joints in thin materials. Welding with a short arc, at the same weld settings, results in greater penetration and a narrower weld and reduces the amount of spatter. To achieve a consistent spatter free and flat weld, you must use an Argon/CO<sup>2</sup> mixture.
- 5.1.5. To weld aluminium use: Argon gas; 0.8mm Contact Tip (MIG917); 0.8mm Aluminium Wire, (MIG/2KAL08).

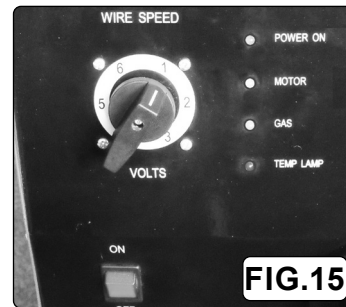
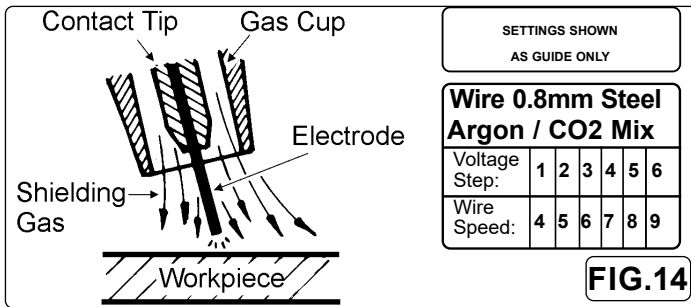

- 5.1.6. **Overload Protection.** Thermostatic overload protection is provided. When an overload occurs the TEMP LAMP on the front panel will light. See fig.15. When an overload has occurred, leave the unit to cool. The thermostat will automatically reset the unit when the temperature has returned within limits.

## 6. MAINTENANCE

- 6.1. **WIRE FEED UNIT** Check the wire feed unit at regular intervals. The feed roller wire guide plays an important part in obtaining consistent results. Poor wire feed affects welding. Clean the rollers weekly, especially the feed roller groove, removing all dust deposits.
- 6.2. **TORCH** Protect the torch cable assembly from mechanical wear. Clean the liner from the machine forwards by using compressed air. If the liner is clogged it must be replaced.
- 6.3. **CHANGING FEED ROLLER** (See Section 4.13)
- 6.4. **CONTACT TIP** The contact tip is a consumable item and must be replaced when the hole becomes enlarged or oval. The contact tip MUST be kept free from spatter to ensure an unimpeded flow of gas. Refer to fig.11 and section 4.10 for removal and replacement.
- 6.5. **GAS CUP** The gas cup must also be kept clean and free from spatter. Build up of spatter inside the gas cup can cause a short circuit at the contact tip which will result in either the fuse blowing on the printed circuit card, or expensive machine repairs. To keep the contact tip free from spatter, we recommend the use of Sealey anti-spatter spray (MIG/722308) available from your Sealey stockist. Refer to fig.11 and section 4.10 for removal and replacement.
- 6.6. **REPLACING THE LINER** Wind the wire back on to the spool and secure it. Unscrew the torch from the machine and undo the brass nut. The liner should now be visible. Pull it out and replace with a new one.

## 7. RATINGS PLATE

On the front of the welder is the ratings plate, giving the following data:

1	The standard relating to the safety and construction of arc welding and associated equipment.
2	Single phase transformer - rectifier.
3	Welding with a continuous flow of welding wire.
4	Single-phase AC supply.
5	Rating of internal protection provided by Casing.
6	Output U <sub>0</sub> : Rated minimum & maximum no load voltage. I <sub>2</sub> , U <sub>2</sub> : Current and corresponding voltage. X: Welding ratio based on a 10 minute cycle. 20% indicates 2 minutes welding and 8 minutes rest, 100% indicates continuous welding.
7	Mains Supply U <sub>1</sub> : Rated supply voltage and frequency. I <sub>max</sub> : Maximum current. I <sub>1eff</sub> : Maximum effective current.
8	Welding current range.
9	Serial Number. Specifically identifies each welder.

②	<b>MIGHTYMIG250.V3</b>	Serial No.	⑨
		<b>EN 60974-6:2012</b>	①
③		Welding Current Range: 50A--250A	⑧
	U <sub>0</sub> = 26-56V	X	15% 60% 100%
		I <sub>2</sub>	250A 140A 110A
		U <sub>2</sub>	26.5V 21V 19.5V
④		U <sub>1</sub> = 230V	I <sub>max</sub> = 48 A
⑤	IP21S	I <sub>1eff</sub> = 22 A	⑦

## 8. TROUBLESHOOTING

PROBLEM	POSSIBLE CAUSE	REMEDY
1. Power source stops	Overheating protection activated due to overload	Protection automatically resets when transformer has cooled (about 15 min)
2. No weld current	Rectifier blown	Replace rectifier
3. No weld current	Bad connection between clamp & workpiece	Clean or grind contact surface and weld area
	Break in earth lead	Repair or replace earth lead.
	Break in torch lead	Repair or replace torch
4. Feed motor not working, lamp is on	Gear damaged or worn	Replace gears. (Contact service agent)
	Motor defective	Replace motor (Contact service agent)

5. Wire does not feed, feed roller rotates	Pressure roller improperly adjusted	Adjust tension
	Dirt, copper, dust, etc, has collected in torch liner	Clean the liner from the machine forward. Use compressed air. If too much dirt, replace the liner.
	Gas cup (Nozzle) or tip defective	Replace gas cup (nozzle) and/or tip.
	Deformed wire	Check roller tension and adjust it if necessary
6. Wire feeds unevenly	Dirt, etc, in liner	Clean the liner from the machine forward. Use compressed air
	Gas cup (Nozzle) or Tip defective	Replace gas cup (nozzle) and/or tip.
	Gas cup (Nozzle) spattered	Clean or replace gas cup (nozzle)
	Feed roller groove clogged	Clean feed roller.
	Feed roller groove deformed	Replace feed roller.
	Pressure roller tension improper	Adjust tension.
7. Unstable arc	Incorrect settings	Check settings.
	Impurities in weld area	Clean and/or grind workpiece.
	Worn or defective gas cup (nozzle)	Replace gas cup (nozzle).
8. Porous weld	No gas	Open gas cylinder, regulate gas flow
	Gas cup clogged	Clean or replace cup. (nozzle)
	Draft blowing away shielding gas	Screen off welding site or increase gas flow
	Rusty or dirty joints	Clean and/or grind workpiece.
	Torch too far from or at wrong angle to work	The distance from gas cup to workpiece should be 8 to 10mm
	Gas leak	Check hoses, connections and torch assembly. Press the gas cup in correction position
	Faulty Electrovalve	Clean out or replace
9. Electrode sticking in gas cup (nozzle)	Worn or defective gas cup (nozzle)	Replace gas cup (nozzle).
	Electrode deformed	Check roller tension.
	Wire speed too slow	See recommendations for wire speed
10. Irregular weld head	Torch incorrectly held	Use correct torch angle
	Wire weaving in weld pool	Check roller tension and adjust as needed.
11. Weld bead too narrow and raised	Weld current too low	Increase power and wire speed.
	Weld speed too high	Move torch slower and weave a little more
12. Weld bead too wide	Weld current too high	Decrease power and wire speed.
	Weld speed too low	Move torch faster and weave less
	Arc too long	Bring torch closer to workpiece
13. Poor penetration	Weld current too low	Increase power and wire speed.
	Arc too long	Bring torch closer to workpiece
14. Excessive penetration	Weld current too high	Decrease power and wire speed.
	Weld speed too slow	Move torch faster
	Incorrect distance of torch to workpiece	Torch distance should be 8-10mm



#### ENVIRONMENT PROTECTION

Recycle unwanted materials instead of disposing of them as waste. All tools, accessories and packaging should be sorted, taken to a recycling centre and disposed of in a manner which is compatible with the environment. When the product becomes completely unserviceable and requires disposal, drain any fluids (if applicable) into approved containers and dispose of the product and fluids according to local regulations.



REGISTER YOUR PURCHASE HERE



#### WEEE REGULATIONS

Dispose of this product at the end of its working life in compliance with the EU Directive on Waste Electrical and Electronic Equipment (WEEE). When the product is no longer required, it must be disposed of in an environmentally protective way. Contact your local solid waste authority for recycling information.

**Note:** It is our policy to continually improve products and as such we reserve the right to alter data, specifications and component parts without prior notice. Please note that other versions of this product are available. If you require documentation for alternative versions, please email or call our technical team on [technical@sealey.co.uk](mailto:technical@sealey.co.uk) or 01284 757505.

**Important:** No Liability is accepted for incorrect use of this product.

**Warranty:** Guarantee is 36 months from purchase date, proof of which is required for any claim. Lifetime guarantee on transformer.

Sealey Group, Kempson Way, Suffolk Business Park, Bury St Edmunds, Suffolk. IP32 7AR



01284 757500



[sales@sealey.co.uk](mailto:sales@sealey.co.uk)



[www.sealey.co.uk](http://www.sealey.co.uk)