

# METAL SHAPING STATION

**ITEM MW19**

## ASSEMBLY & OPERATING INSTRUCTIONS

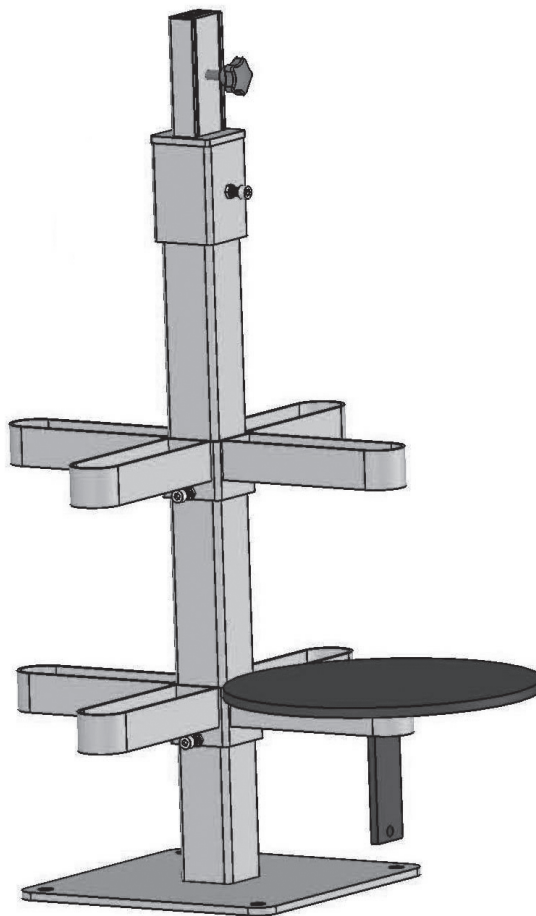

Diagrams within this manual may not be drawn proportionally.  
Due to continuing improvements, actual product may differ slightly from the product described herein.



**Read this material before using this product.  
Failure to do so can result in serious injury.  
SAVE THIS MANUAL.**

---

## SPECIFICATIONS

Overall Height (mm//in)	885//34-3/4
-------------------------	-------------

### SAVE THIS MANUAL

You will need the manual for the safety warnings and precautions, assembly instructions, operating and maintenance procedures, parts list and diagram. Keep your invoice with this manual. Write the invoice number on the inside of the front cover. Keep the manual and invoice in a safe and dry place for future reference.

### SAFETY WARNINGS AND PRECAUTIONS

**WARNING:** When using tool, basic safety precautions should always be followed to reduce the risk of personal injury and damage.

**Read all instructions before using this tool!**

- 1. Keep work area clean.** Cluttered areas invite injuries.
- 2. Observe work area conditions.** Do not use machines or power tools in damp or wet locations. Don't expose to rain. Keep work area well lighted. Do not use electrically powered tools in the presence of flammable gases or liquids.
- 3. Keep children away.** Children must never be allowed in the work area. Do not let them handle machines, tools, or extension cords.
- 4. Store idle equipment.** When not in use, tools must be stored in a dry location to inhibit rust. Always lock up tools and keep out of reach of children.
- 5. Do not force tool.** It will do the job better and more safely at the rate for which it was intended. Do not use inappropriate attachments in an attempt to exceed the tool capacity.
- 6. Use the right tool for the job.** Do not attempt to force a small tool or attachment to do the work of a larger industrial tool. Do not modify this tool and do not use this tool for a purpose for which it was not intended.
- 7. Dress properly.** Do not wear loose clothing or jewelry as they can be caught in moving parts. Protective, electrically non-conductive clothes and non-skid footwear are recommended when working. Wear restrictive hair covering to contain long hair.
- 8. Use eye and ear protection.** Always wear ANSI approved impact safety goggles. Wear a full face shield if you are producing metal filings or wood chips. Wear an ANSI approved dust mask or respirator when working around metal, wood, and chemical dusts and mists.
- 9. Do not overreach.** Keep proper footing and balance at all times. Do not reach over or across running machines. Keep hands and fingers clear of the Roll Dies when operating.

- 10. Maintain tools with care.** Keep tools sharp and clean for better and safer performance. Follow instructions for lubricating and changing accessories. Inspect tool cords periodically and, if damaged, have them repaired by an authorized technician. The handle must be kept clean, dry, and free from oil and grease at all times.
- 11. Stay alert.** Watch what you are doing, use common sense. Do not operate any tool when you are tired.
- 12. Check for damaged parts.** Before using any tool, any part that appears damaged should be carefully checked to determine that it will operate properly and perform its intended function. Check for alignment and binding of moving parts; any broken parts or mounting fixtures; and any other condition that may affect proper operation. Any part that is damaged should be properly repaired or replaced by a qualified technician. Do not use the tool if any switch does not turn on and off properly.
- 13. Replacement parts and accessories.** When servicing, use only identical replacement parts. Use of any other parts will void the warranty. Only use accessories intended for use with this tool.
- 14. Do not operate tool if under the influence of alcohol or drugs.** Read warning labels if taking prescription medicine to determine if your judgment or reflexes are impaired while taking drugs. If there is any doubt, do not operate the tool.
- 15. Maintenance.** For your safety, service and maintenance should be performed regularly by a qualified technician.
- 16. Workpiece may be sharp.** After bending or cutting workpieces use caution. Be aware of sharp edges or sharp shreds of metal that may be created. Use heavy duty gloves when handling the workpiece.

**WARNING:** The warnings, cautions, and instructions discussed in this instruction manual cannot cover all possible conditions and situations that may occur. It must be understood by the operator that common sense and caution are factors which cannot be built into this product, but must be supplied by the operator.

## **FEATURES**

1. A more versatile way to hold t-dollies during the forming process.
2. Hold most any size dolly.
3. Mounting holes are located on the base for anchoring to the floor

## **UNPACKING**

When unpacking, check to make sure that the item is intact and undamaged. If any parts are missing or broken, please contact the seller.

## **ASSEMBLY AND OPERATION**

**Note:** For additional information regarding the parts listed in the following pages, refer to the Parts Diagram.

1. Slide the Storage Rack (2#) onto the Stand (1#), then tighten two Screws (5#).
2. Slide the Dolly Adapter (3#) onto the Stand (1#), then tighten Screw (5#).
3. Insert the Plate (7#) into the hole of the Dolly Adapter (3#).
4. Place the dolly into the hole of the Dolly Adapter (3#), and tighten Knob(4#).

## PARTS LIST

Part No.	Description	Qty
1	Stand	1
2	Storage Rack	2
3	Dolly Adapter	1
4	Knob	2
5	Screw M8x20	4
6	Wrench 6mm	1
7	Plate	1
9	Nut	4

## PARTS DIAGRAM

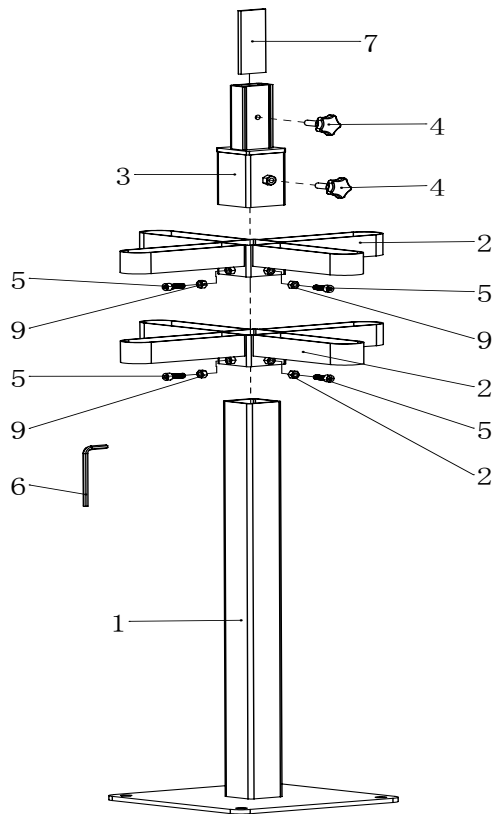

### PLEASE READ THE FOLLOWING CAREFULLY

THE MANUFACTURER AND/OR DISTRIBUTOR HAS PROVIDED THE PARTS DIAGRAM IN THIS MANUAL AS A REFERENCE TOOL ONLY. NEITHER THE MANUFACTURER NOR DISTRIBUTOR MAKES ANY REPRESENTATION OR WARRANTY OF ANY KIND TO THE BUYER THAT HE OR SHE IS QUALIFIED TO MAKE ANY REPAIRS TO THE PRODUCT OR THAT HE OR SHE IS QUALIFIED TO REPLACE ANY PARTS OF THE PRODUCT. IN FACT, THE MANUFACTURER AND/OR DISTRIBUTOR EXPRESSLY STATES THAT ALL REPAIRS AND PARTS REPLACEMENTS SHOULD BE UNDERTAKEN BY CERTIFIED AND LICENSED TECHNICIANS AND NOT BY THE BUYER. THE BUYER ASSUMES ALL RISK AND LIABILITY ARISING OUT OF HIS OR HER REPAIRS TO THE ORIGINAL PRODUCT OR REPLACEMENT PARTS THERETO, OR ARISING OUT OF HIS OR HER INSTALLATION OF REPLACEMENT PARTS THERETO.