



SMALL ENGLISH WHEEL FOR SHEET METAL SHAPING/FORMING & CAR BODY REPAIR

MODEL NO: MW21

Thank you for purchasing a Sealey product. Manufactured to a high standard, this product will, if used according to these instructions, and properly maintained, give you years of trouble free performance.

IMPORTANT: PLEASE READ THESE INSTRUCTIONS CAREFULLY. NOTE THE SAFE OPERATIONAL REQUIREMENTS, WARNINGS & CAUTIONS. USE THE PRODUCT CORRECTLY AND WITH CARE FOR THE PURPOSE FOR WHICH IT IS INTENDED. FAILURE TO DO SO MAY CAUSE DAMAGE AND/OR PERSONAL INJURY AND WILL INVALIDATE THE WARRANTY. KEEP THESE INSTRUCTIONS SAFE FOR FUTURE USE.



Refer to instruction manual



Wear a face shield



Wear protective gloves

1. SAFETY

- ✓ Keep the manual for the safety warnings and precautions, assembly instructions, operating and maintenance procedures, parts list and diagram. Keep the manual in a safe and dry place for future reference.
- ✓ Keep work area clean. Cluttered areas invite injuries. Observe work area conditions.
- ✗ **DO NOT** use machines in damp or wet locations. **DO NOT** expose to rain. Keep work area well lit.
- ✓ Keep children away. Children must never be allowed in the work area. **DO NOT** let them handle machines or tools.
- ✓ Store idle equipment. When not in use, tools must be stored in a dry location to inhibit rust. Always lock up tools and keep out of reach of children.
- ✗ **DO NOT** force tool. It will do the job better and more safely at the rate for which it was intended. **DO NOT** use inappropriate attachments in an attempt to exceed the tool capacity.
- ✓ Use the right tool for the job. **DO NOT** attempt to force a small tool or attachment to do the work of a larger industrial tool.
- ✗ **DO NOT** modify this tool and do not use this tool for a purpose for which it was not intended.
- ✓ Dress properly. **DO NOT** wear loose clothing or jewellery as they can be caught in moving parts.
- ✓ Protective, electrically non-conductive clothes and non-skid footwear are recommended when working.
- ✓ Wear restrictive hair covering to contain long hair.
- ✓ Use eye protection. Always wear approved impact safety goggles. Wear a full face shield if you are producing metal filings or wood chips. Wear approved dust mask or respirator when working around metal, wood, and chemical dusts and mists.
- ✗ **DO NOT** overreach. Keep proper footing and balance at all times. **DO NOT** reach over or across operating machines. Keep hands and fingers clear of the Roll Dies when operating.
- ✓ Maintain tools with care. Keep tools sharp and clean for better and safer performance. Follow instructions for lubricating and changing accessories.
- ✓ Keep must be kept clean, dry, and free from oil and grease at all times.
- ✓ Remove adjusting keys and wrenches. Check that keys and adjusting wrenches are removed from the tool or machine work surface before use.
- ✓ Stay alert. Watch what you are doing, use common sense. **DO NOT** operate any tool when you are tired.
- ✓ Check for damaged parts. Before using any tool, any part that appears damaged should be carefully checked to determine that it will operate properly and perform its intended function.
- ✓ Check for alignment and binding of moving parts; any broken parts or mounting fixtures; and any other condition that may affect proper operation. Any part that is damaged should be properly repaired or replaced by a qualified technician.
- ✓ Replacement parts and accessories. When servicing, use only identical replacement parts. Use of any other parts will void the warranty. Only use accessories intended for use with this tool.
- ✗ **DO NOT** operate tool if under the influence of alcohol or drugs. Read warning labels if taking prescription medicine to determine if your judgment or reflexes are impaired while taking drugs. If there is any doubt, do not operate the tool.
- ✓ Maintenance. For your safety, service and maintenance should be performed regularly by a qualified technician.
- ✓ Workpiece may be sharp. After bending or cutting workpieces use caution. Be aware of sharp edges or sharp shreds of metal that may be created. Use heavy duty gloves when handling the workpiece.
- ☐ **WARNING!** The warnings, cautions, and instructions discussed in this instruction manual cannot cover all possible conditions and situations that may occur. It must be understood by the operator that common sense and caution are factors which cannot be built into this product, but must be supplied by the operator.

2. INTRODUCTION

Creates smooth radian surfaces in sheet metal without the need for heating or hammering. Easy adjustment and assembly for precise metal shaping tasks. Bottom anvil dies offer different radii for a variety of shaping needs. All-steel construction ensures ruggedness and longevity. Can be vice mounted or mounted on the optional floor stand.

3. SPECIFICATION

Model No:MW21
Bottom Die Sizes: 1/2", 1", 1-1/2", 2-1/2", 5", 9", Flat
Weight: 12.6kg
Throat: 15-3/4"
Top Die Sizes: Ø5-3/4"

4. ASSEMBLY

Numbers refer to attached Parts List

- 4.1. Place the Top Die (2#) into the bracket at the top of the unit. Fix in place with the Top Die Shaft (3#) and secure with the Circlip (4#).
- 4.2. Put the Anvil Bracket (5#) into the holder at the end of the Frame (1#).
- 4.3. Screw the Adjusting Screw (14#) into the unit.
- 4.4. Screw the Knob (9#) into the threaded hole on Frame (1#). Lift Anvil Bracket (5#) to let the Knob (9#) seat into the slot of Anvil Bracket (5#). Tighten Knob (9#).
- 4.5. Place the two pieces of the Die Rack (13#) onto the unit and secure with Nut M6 (11#) , Washer 6mm (8#) and Bolt M6x40 (15#).
- 4.6. Secure the English Wheel at its mid-point with a vice.
- 4.7. Only mount the English Wheel on a work surface that is capable of supporting both the weight of the Wheel and the work piece.
- 4.8. Slide the Anvil Shafts (6#) through the hole in the Anvils (12-01#,12-02#,12-03#,12-04#,12-05#,12-06#,12-07#) and place them in the Die Rack (13#).
- 4.9. Connect Angle Steel (16#) with Frame (1#) with Bolt M8x45 (17#), Washer 8mm (18#) and Nut M8 (19#).

5. OPERATION

- 5.1. Always wear work gloves when performing operations with the English Wheel.
- 5.2. Select the proper Anvil (12-01#,12-02#,12-03#,12-04#,12-05#,12-06#,12-07#) for the job and place it on the Anvil Bracket (5#).
- 5.3. Insert the work piece between the Top Die (2#) and the chosen Anvil (12-01#, 12-02#, 12-03#, 12-04#,12-05#,12-06#,12-07#).
- 5.4. Turn the Adjusting Screw (14#) until the Top Die (2#) and the Anvil(12-01#, 12-02#, 12-03#,12-04#,12-05#,12-06#,12-07#) engage the metal.
- 5.5. It is recommended to have a loose pinch, rather than a tight one. A tight pinch will make it harder to move the metal and may cause creasing. A loose pinch makes it easy to move the metal, and allows greater accuracy. Although, it may take more passes to form the metal.
- 5.6. Form the metal by pushing and pulling it between the dies.
- 5.7. When finished, loosen the Adjusting Screw (14#) and remove the work piece from the English Wheel.
- 5.8. Clean, then store the product indoors out of children's reach.

6. MAINTENANCE

- 6.1. Keep the machine clean. **DO NOT** solvent based products.
- 6.2. Lubricate moving parts with grease.

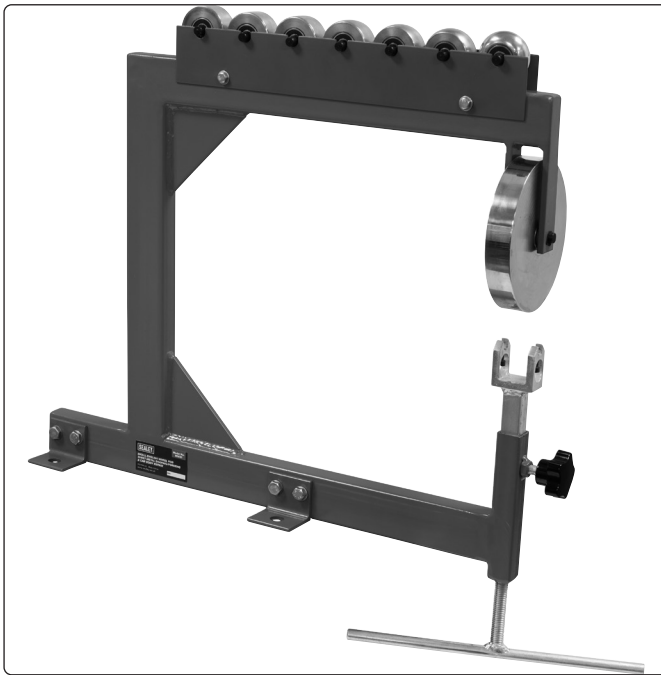

ENVIRONMENT PROTECTION

Recycle unwanted materials instead of disposing of them as waste. All tools, accessories and packaging should be sorted, taken to a recycling centre and disposed of in a manner which is compatible with the environment. When the product becomes completely unserviceable and requires disposal, drain any fluids (if applicable) into approved containers and dispose of the product and fluids according to local regulations.

Note: It is our policy to continually improve products and as such we reserve the right to alter data, specifications and component parts without prior notice.

Important: No Liability is accepted for incorrect use of this product.

Warranty: Guarantee is 12 months from purchase date, proof of which is required for any claim.



REGISTER YOUR PURCHASE HERE

Sealey Group, Kempson Way, Suffolk Business Park, Bury St Edmunds, Suffolk. IP32 7AR



01284 757500



sales@sealey.co.uk



www.sealey.co.uk