

Thank you for purchasing a More Tools product. Manufactured to a high standard this product will, if used according to these instructions and properly maintained, give you years of trouble free performance.

**IMPORTANT: PLEASE READ THESE INSTRUCTIONS CAREFULLY. NOTE THE SAFE OPERATIONAL REQUIREMENTS, WARNINGS AND CAUTIONS. USE THE PRODUCT CORRECTLY AND WITH CARE FOR THE PURPOSE FOR WHICH IT IS INTENDED. FAILURE TO DO SO MAY CAUSE DAMAGE AND/OR PERSONAL INJURY AND WILL INVALIDATE THE WARRANTY. PLEASE KEEP INSTRUCTIONS SAFE FOR FUTURE**

## 1. SAFETY INSTRUCTIONS

### 1.1. ELECTRICAL SAFETY.

**WARNING! It is the user's responsibility to read, understand and comply with the following:**

You must check all electrical equipment and appliances to ensure they are safe before using. You must inspect power supply leads, plugs and all electrical connections for wear and damage. You must ensure the risk of electric shock is minimised by the installation of appropriate safety devices. An RCCB (Residual Current Circuit Breaker) should be incorporated in the main distribution board. We also recommend that an RCD (Residual Current Device) is used with all electrical products. It is particularly important to use an RCD with portable products that are plugged into an electrical supply not protected by an RCCB. If in doubt consult a qualified electrician. You may obtain a Residual Current Device by contacting your dealer. **You must** also read and understand the following instructions concerning electrical safety.

- 1.1.1. The **Electricity At Work Act 1989** requires all portable electrical appliances, if used on business premises, to be tested by a qualified electrician, using a Portable Appliance Tester (PAT), at least once a year.
- 1.1.2. The **Health & Safety at Work Act 1974** makes owners of electrical appliances responsible for the safe condition of the appliance and the safety of the appliance operator. **If in any doubt about electrical safety, contact a qualified electrician.**
- 1.1.3. Ensure the insulation on all cables and the product itself is safe before connecting to the mains power supply. See 1.1.1. & 1.1.2. above and use a Portable Appliance Tester (PAT).
- 1.1.4. Ensure that cables are always protected against short circuit and overload.
- 1.1.5. Regularly inspect power supply, leads, plugs for wear and damage and all electrical connections to ensure that none is loose.
- 1.1.6. **Important:** Ensure the voltage marked on the product is the same as the electrical power supply to be used and check that plugs are fitted with the correct capacity fuse. A 13 amp plug may require a fuse smaller than 13 amps for certain products, see fuse rating at right.
- 1.1.7. DO NOT pull or carry the powered appliance by its power supply lead.
- 1.1.8. DO NOT pull power plugs from sockets by the power cable.
- 1.1.9. DO NOT use worn or damaged leads, plugs or connections. Immediately replace or have repaired by a qualified electrician. A U.K. 3 pin plug with ASTA/BS approval is fitted. In case of damage, cut off and fit a new plug according to the following instructions (discard old plug safely).

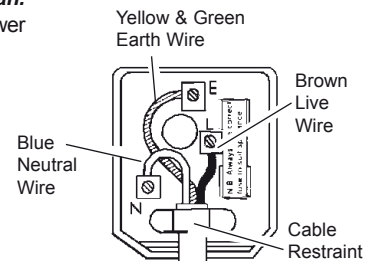

**FUSE RATING**  
 THIS PRODUCT MUST BE FITTED  
 WITH A  
**13 AMP FUSE**

(UK only - see diagram at right). **Ensure the unit is correctly earthed via a three-pin plug.**

- a) **Connect the GREEN/YELLOW earth wire to the earth terminal 'E'.**
- b) **Connect the BROWN live wire to live terminal 'L'.**
- c) **Connect the BLUE neutral wire to the neutral terminal 'N'.**
- d) **After wiring, check there are no bare wires, that all wires have been correctly connected, that cable outer insulation extends beyond the cable restraint and that the restraint is tight.**

Double insulated products are fitted with live (BROWN) and neutral (BLUE) wires only. Double insulated products are always marked with this symbol . **To re-wire, connect the brown & blue wires as indicated above. DO NOT connect the brown or blue to the earth terminal.**

- 1.1.10. **Cable extension reels.** When a cable extension reel is used it should be fully unwound before connection. A cable reel with an RCD fitted is recommended since any product which is plugged into the cable reel will be protected. The section of the cores of the cable is important. We suggest 1.5mm<sup>2</sup> section as a minimum but to be absolutely sure that the capacity of the cable reel is suitable for this product and for others that may be used in the other output sockets, we recommend the use of 2.5mm<sup>2</sup> section cable.

### 1.2. GENERAL SAFETY

- WARNING! Ensure Health & Safety, local authority, and general workshop practice regulations are adhered to when using this equipment.**
- ✓ Familiarise yourself with the applications, limitations and hazards associated with this product.
- WARNING!** Disconnect from the mains power and ensure the disc is at a complete standstill before changing accessories, servicing or performing any maintenance.
- ✓ Maintain the sander/polisher in good condition (use an authorised service agent).
- ✓ Replace or repair damaged parts. *Use genuine parts only. Unauthorised parts may be dangerous and will invalidate the warranty.*
- WARNING!** Keep all guards and holding screws in place, tight and in good working order. Check regularly for damaged parts. A guard or any other part that is damaged must be repaired/replaced before the tool is next used.
- ✓ Locate sander/polisher in a suitable working area, keep area clean and tidy and free from unrelated materials. Ensure there is adequate lighting.
- ✓ Keep the sander/polisher clean for best and safest performance.
- ✓ Before each use check abrasive attachments for condition. If worn or damaged replace immediately.
- ✓ Ensure there are no flammable or combustible materials near the work area.
- WARNING!** Wear approved eye safety protection, ear defenders and, if dust is generated, respiratory protection.
- ✓ Maintain correct balance and footing. Ensure the floor is not slippery and wear non-slip shoes.
- ✓ Remove ill fitting clothing. Remove ties, watches, rings, and other loose jewellery, and contain and/or tie back long hair.
- ✓ Keep children and unauthorised persons away from the working area.
- ✓ Secure unstable workpiece with a clamp, vice or other adequate holding device.
- ✓ Remove adjusting keys and wrenches from the machine and its vicinity before turning it on.
- x **DO NOT** use equipment for any purpose other than that for which it is designed.
- x **DO NOT** operate the sander/polisher if any parts are damaged or missing as this may cause failure and/or possible personal injury.
- WARNING! DO NOT** sand any materials containing asbestos.
- x **DO NOT** switch the sander/polisher on whilst the head is in contact with the work-piece and avoid unintentional starting.
- x **DO NOT** get the sander/polisher wet or use in damp or wet locations or areas where there is condensation.



- x **DO NOT** operate spindle lock button while pad is rotating.
- x **DO NOT** operate power control while spindle lock is operating.
- x **DO NOT** allow untrained persons to operate the sander/polisher.
- x **DO NOT** operate the sander/polisher when you are tired or under the influence of alcohol, drugs or intoxicating medication.
- x **DO NOT** use the sander/polisher where there are flammable liquids, solids or gases such as paint solvents, etc.
- x **DO NOT** leave the sander/polisher operating unattended.
- x **DO NOT** carry the sander/polisher with your finger on the power switch.
- x **DO NOT** pull the cord to remove the plug from the power supply.
- ✓ Use a qualified person to lubricate and maintain the sander/polisher.
- ✓ When not in use unplug from the mains power supply and store in a safe, dry, childproof area.

**LEAD PAINT WARNING!** Paint once contained lead as a traditional ingredient. Contact with the dust from the removal of such paint is toxic and must therefore be avoided.

The following action must be taken before using machine as a sander:

1. User must determine potential hazard relating to age of paint to be removed. (Modern paints do not have lead content).
2. **DANGER!** Keep all persons and pets away from the working area. The following are particularly vulnerable to the effects of lead paint dust: **Expectant women, babies and children.**
3. We recommend personal protection by using the following safety items:  
A) *Paint Spray Respirator.* B) *PE Coated Hooded Coverall.* C) *Latex Gloves.*
4. Take adequate measures to contain paint dust, flakes and scrapings. Wear safety equipment, as in (3) above, and thoroughly clean all areas when task is complete.
5. Ensure the paint waste is disposed of in sealed bags or containers according to local regulations.

## 2. INTRODUCTION

Features variable speed control giving a range suitable for both sanding and polishing. Speeds from 660 to 3000rpm. Alloy bevel gear head with composite motor housing. D-handle is reversible for left or right hand use. Spindle lock for easy pad removal. Safety button to prevent accidental start-up. Supplied with Ø180mm hook-and-loop backing pad, polishing bonnet, spare brushes and hex key.

## 3. TECHNICAL SPECIFICATION

Model: MTSP.V2	
Nominal Power Rating	1200Watts
No Load Speed Range	660 - 3000rpm
Pad Size	180mm
Sound Level	90.1dB Power - 85.1dB Pressure
Vibration Level	5.1m/s <sup>2</sup>
Spindle	M14
Supply Lead	2mtr

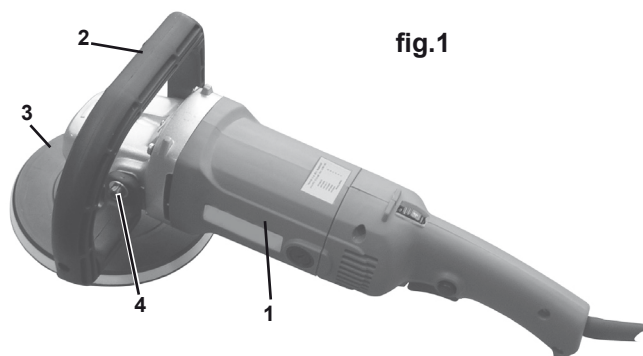

## 4. CONTENT & ASSEMBLY

### 4.1. Content

- 4.1.1. Check the contents of the carton. If any item is missing or damaged contact your supplier immediately.

**Fig1.1. Polisher Unit, 2. D Handle, 3. Pad. Polishing Mop, Spare Brushes and Allen Key.**

### 4.2. Assembly

- ☐ **WARNING! Ensure unit is not plugged into mains before attempting any assembly.**

- 4.2.1. Attach the D handle using the two Allen Bolts (fig.1.4). Note: The handle is reversible to suit the application and/or operator.

- 4.2.2. To attach a sanding disc:

Spin rubber pad (fig 2.3) on shaft (S), tighten/loosen by hand whilst holding the spindle steady with locking button (fig.4). Follow with sandpaper disc (D).

- 4.2.3. To fit a polishing bonnet:

Fit rubber pad (fig 3.3) on spindle (S), tighten/loosen by hand whilst holding the spindle steady with locking button (fig.4). Neatly fit the polishing bonnet (Z) over the secured rubber pad.

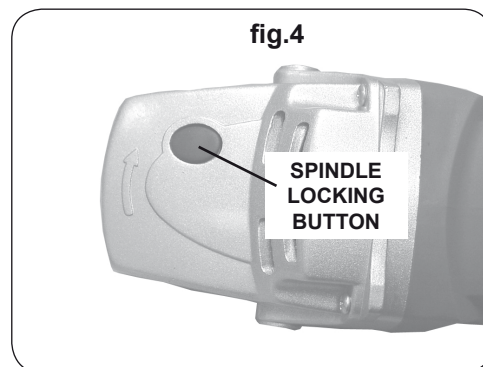
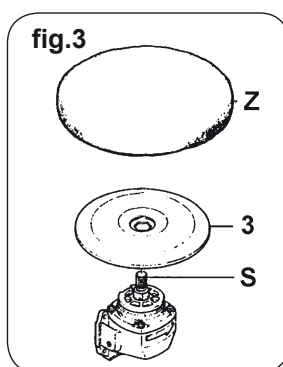
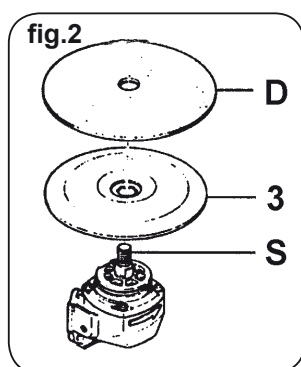

## 5. OPERATION

- WARNING! Ensure you read, understand and apply the safety instructions in Section 1.**
- 5.1. Hold the sander/polisher firmly with one hand on the handle grip and the other on the D-Handle. To select the required speed rotate the speed selector switch (fig. 5.2) to the required speed 1 to 6. 1 = slowest, 6 = fastest.
- 5.2. To start the machine press and hold down the safety lock button (fig.5.1) and squeeze the trigger. When releasing the trigger, the safety lock button will engage, preventing inadvertent starting.
- WARNING! The high speed settings are intended for sanding. If used for polishing an excessive amount of surface material may be removed.**

**Note:** As the rubber support disc is flexible, when sanding it should not be used head on, but at an angle of approximately 10 to 20 degrees. Contact your dealer for details of compounding heads and lambswool bonnets.

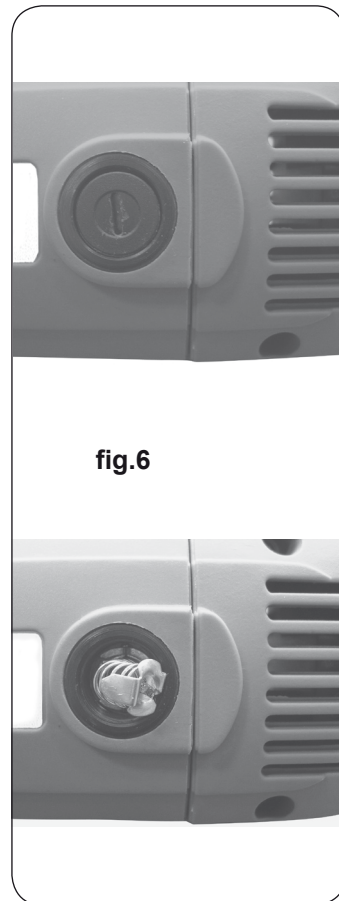
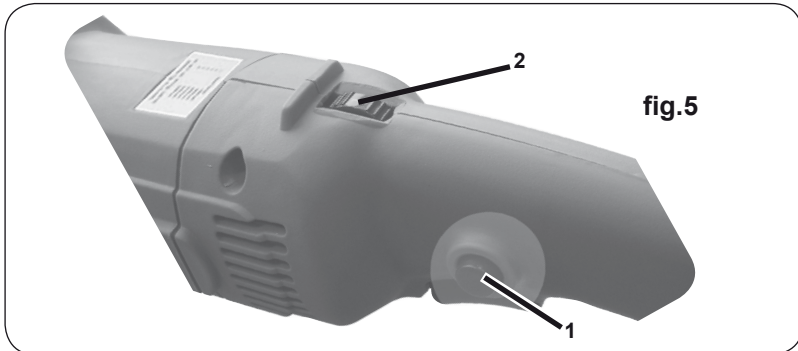

## 6. MAINTENANCE

- WARNING! Before attempting any maintenance ensure the unit is unplugged from the mains power supply.**
- 6.1. Keep the machine clean and dry. Do not use abrasives to clean the unit. Ensure all external head screws are tight.
- 6.2. Clean regularly by blowing a jet of compressed air through side vents to ensure motor ventilation is kept clear.
- WARNING! Wear approved safety eye protection and, if necessary, respiratory protection.**

**Note.** The following maintenance must only be carried out by a technically qualified person or an authorised service agent.

- 6.3. Check carbon brushes by removing each side screw (fig.6). Check to see if the brushes are worn or if cracked. If so, the brush must be replaced to avoid sparking and damage to the armature. Use only genuine spare parts as these are specifically designed for the machine. Failure to do so may be dangerous and will invalidate your warranty.
- 6.4. After each 500 hours of use replace the gear head grease to prevent gear wear and possible drive failure.

### Risk of Hand Arm Vibration Injury

#### MTSP SANDER/POLISHER 180MM VARIABLE SPEED 1200W 230V

when operated in accordance with these instructions and tested in accordance with EN 28662-1: 1993 results in the following vibration emission declared in accordance with BS EN12096: 1996.

Measured vibration emission value: 5.1m/s<sup>2</sup>

Uncertainty: 2.04m/s<sup>2</sup>

**These values are suitable for comparison with emission levels of other tools that have been subject to the same test.**

**This tool may cause hand-arm vibration syndrome if its use is inadequately managed.**

#### Recommended Measures to reduce risk of hand-arm vibration syndrome:

This tool should not be used by an individual regularly for more than 3.92 hours in any 8 hour period.

This duration of use should be reduced if the individual is exposed to hand-arm vibration from other sources.

**NOTE:** It is our policy to continually improve products and as such we reserve the right to alter data, specifications and component parts without prior notice.

**IMPORTANT:** No liability is accepted for incorrect use of this product.

**WARRANTY:** Guarantee is 12 months from purchase date, proof of which will be required for any claim.



Unit 2, Baird Road  
Enfield, Middlesex  
EN1 1SJ



020 8351 5171



020 8351 5172