

Thank you for purchasing a Sealey product. Manufactured to a high standard this product will, if used according to these instructions and properly maintained, give you years of trouble free performance.

**⚠ IMPORTANT: PLEASE READ THESE INSTRUCTIONS CAREFULLY. NOTE THE SAFE OPERATIONAL REQUIREMENTS, WARNINGS & CAUTIONS. USE THE PRODUCT CORRECTLY AND WITH CARE FOR THE PURPOSE FOR WHICH IT IS INTENDED. FAILURE TO DO SO MAY CAUSE DAMAGE AND/OR PERSONAL INJURY AND WILL INVALIDATE THE WARRANTY. PLEASE KEEP INSTRUCTIONS SAFE FOR FUTURE USE.**

## 1. SAFETY INSTRUCTIONS

- ❑ **WARNING!** *Ensure Health & Safety, local authority and general workshop practice regulations are adhered to when using this equipment.*
- ✓ Use a qualified person to lubricate and maintain the lift. DO NOT use brake fluid to top up hydraulic unit. Use Sealey hydraulic oil only.
- ✓ Replace or repair damaged parts. *Use genuine parts only. Unauthorised parts may be dangerous and will invalidate the warranty.*
- ✓ Keep the lift clean for best and safest performance.
- ✓ Before use, ensure that the transportation plug in the hydraulic unit is replaced by the vented plug (see fig1.7).
- ✓ Locate the lift in a suitable work area. Keep area clean and tidy and free from unrelated materials, and ensure that there is adequate lighting.
- ❑ **WARNING!** Use lift on level and solid ground, preferably concrete. *Avoid tarmac/adam since the lift may sink into the surface.*
- ✓ Maintain correct balance and footing. Ensure that the floor is not slippery and wear non-slip shoes.
- ✓ Keep children and non-essential persons away from the work area.
- ✓ Never operate the lift with a load heavier than 700kg. Ensure the load is evenly distributed on the platform and secured if necessary.
- ✓ Before lifting check that there are no overhead obstructions.
- ✓ Always raise the platform fully to either the first or second locking point.
- ✓ When work is complete, check under the platform to ensure that there are no obstructions and that it is safe to lower the unit.
- ✗ DO NOT operate the lift if any parts are damaged or missing as this may cause failure and/or possible personal injury.
- ✗ DO NOT place any part of your body within or under the lift during use.
- ✗ DO NOT operate the lift when you are tired or under the influence of alcohol, drugs or intoxicating medication.
- ✗ DO NOT use the lift for any purpose other than that for which it is designed.
- ✗ DO NOT allow untrained persons to operate the lift.
- ✗ DO NOT attempt to move the lift whilst it is supporting a tractor.
- ✗ DO NOT allow any person to lean, lie, sit or stand on the lift at any time, especially when it is operating.
- ✗ DO NOT allow power tool cables to pass anywhere beneath the lift.
- ✗ DO NOT allow the lift to get wet. Do not expose the lift to rain or excessive moisture/humidity.
- ✓ Use lift indoors only.
- ✓ Ensure that operators read the manual and that the manual is available to new operators or new owners of the lift.
- ✓ Ensure that the specification plate is not removed from the lift and is in good, readable condition.
- ✓ Store lift in a dry, childproof area when not in use.

## 2. INTRODUCTION

The MT700 Mini Tractor Lift is of all-steel construction with a heavy-duty hydraulic ram. Supplied with a separate, foot operated, hydraulic pump and reservoir unit. Full width ramp and platform with chequer plate surface for secure loading and positioning of mini tractor. Fitted with overrun guard at front of platform and mechanical safety lock to prevent accidental lowering.

- ❑ **WARNING!** Ensure that there is adequate clearance between the underside of the mini tractor and the point where the loading ramp and platform meet. Failure to do so may cause damage.

## 3. SPECIFICATION

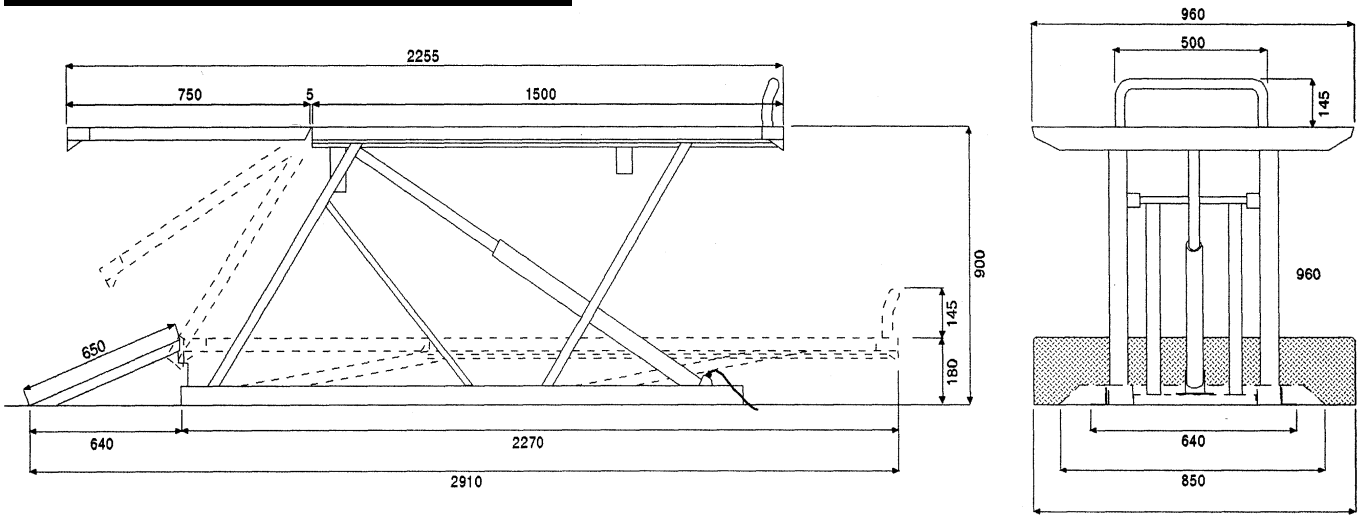

<b>SPECIFICATION:</b>	
Capacity . . . . .	700kg
Height Min/Max . . . . .	180/900mm
Width x Length . . . . .	960 x 2255mm
Weight of pump unit . . . . .	8kg
Weight of lift . . . . .	170kg
Overall weight with accessories .	180kg

## 4. INSTALLATION

- 4.1 CONTENTS:** The lift comes in two boxes. One contains the lift and loading ramp and weighs approximately 170kg. The other contains the pump, flexible hose and air vent cap and weighs approximately 10kg. The boxes should not be turned upside down.
- 4.2 INSTALLATION SITE:**  
The lift should be transported to its installation site by fork lift truck.
- 4.2.1 In general there should be a minimum clearance of 1 metre all around the lift in order to give operators adequate access to the lift and the tractor on it. A clear approach to the ramp is also required to safely load a tractor.
- 4.2.2 The working area should have a solid, flat and even floor. The area should be well lit and free from extraneous materials.
- 4.2.3 The lift can be free standing or fixed to a solid concrete floor using using M10 x 100mm expansion bolts.
- 4.3 CONNECTING THE FOOT PUMP:**
- 4.3.1 Remove the protective cap from the connector situated at the pedal end of the pump. (See fig1.1)
- 4.3.2 Place a copper washer onto the exposed thread (See fig2.1) and screw the descent control valve ( 2.2 ) onto the connector as shown in fig.2.
- 4.3.3 Connect the pump to the hydraulic cylinder on the lift using the flexible pipe provided.
- 4.3.4 Check that all connections are tight.
- 4.3.5 Remove the transport cap from the top face of the pump reservoir ( See fig1.7 ) and replace it with the vented plastic cap supplied.
- 4.4 EXPELLING AIR FROM THE SYSTEM:**
- 4.4.1 To bleed the system first operate the foot pump pedal (See fig1.8) continuously through its full stroke until the platform reaches its full height and the locking frame and cam have passed over the second stop position.
- 4.4.2 Raise the platform slightly and lift the locking frame so that the cam rotates downwards ( See fig.5 ) allowing the lower bar of the locking leg to pass over the stop point when the platform is lowered using the descent valve lever on the foot pump. ( See fig1.9 ).
- 4.4.3 Repeat this process several times until smooth ascent and descent are achieved.
- 4.5 CHECKS BEFORE USE:** Make the following checks before using the lift for the first time.
- 4.5.1 Check that there is no sign of breakage or damage to the to the mechanical structure of the lift.
- 4.5.2 Check that all mechanical safety devices are functioning.
- 4.5.3 Ensure that there are no oil leaks.
- 4.5.4 Check that all circlips attached to the pivots are in place.

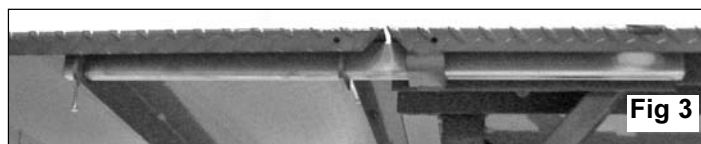
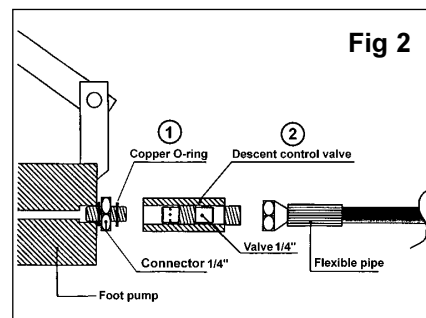
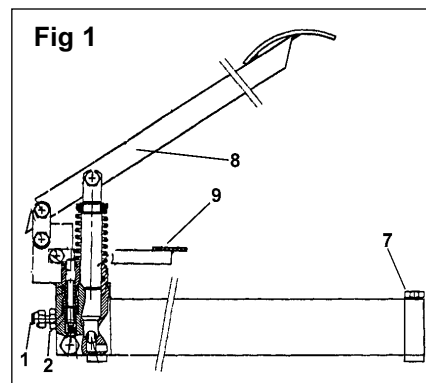

## 5. OPERATING INSTRUCTIONS

### 5.1. RAISING THE PLATFORM

- 5.1.1. Check that the hinged part of the platform is in the raised, horizontal position and is properly locked in place with the sliding support bars fully inserted into the main platform. Refer to fig.3.
- 5.1.2. Before use, check that the lift is level on a suitable surface, and that the platform is fully lowered.
- 5.1.3. Take the overrun guard and insert it into the recesses in the platform. (See item 6 on the parts diagram.)
- 5.1.4. Place the removable loading ramp so that its front edge is resting on the main frame and is butted up against the lowered platform.
- WARNING!** Ensure that there will be adequate clearance between the underside of the mini tractor and the point where the loading ramp and platform meet. Failure to do so may cause damage.
- 5.1.5. Position the mini tractor on the platform and apply the handbrake.
- 5.1.6. Raise the platform by pumping the foot pedal. Continue to pump until the locking frame and cam have passed over the first locking point as shown in fig.4. Briefly depress the descent valve ( see fig1.9 ) so that the locking frame rests firmly against the stop points. If greater working height is required continue to operate the pump lever until the locking frame has passed the second locking point. Ensure that the locking frame is firmly against the locking points. The platform must always be raised to one of the two locking points. Never stop/leave the platform before the first stop point or in between locking points.
- 5.1.7. If the handbrake needs to be released for servicing purposes ensure that wheels are chocked and/or the tractor is suitably restrained with straps before the handbrake is released.
- 5.1.8. The hinged portion of the platform may be lowered if desired for greater access. To do this the platform must be supported by a person at either side whilst the sliding support bars are moved out from underneath the main platform. When the bars are fully retracted the flap can be lowered.
- 5.1.9. The removable loading ramp may be lifted out of the way if desired.

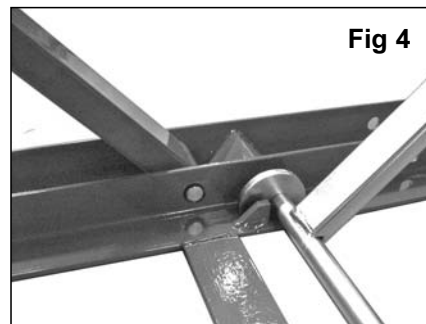

### 5.2. LOWERING THE PLATFORM

- 5.2.1. When work is complete, check under the platform to ensure that there are no obstructions and that it is safe to lower the unit. Ensure that there are no electrical cables, airlines or hoses of any sort passing beneath the platform.
- 5.2.2. Ensure that the hinged portion of the platform is in the raised ( horizontal ) position and its supporting bars are engaged. ( See fig.3 )
- 5.2.3. Place the loading/unloading ramp into position if previously removed.
- 5.2.4. To disconnect the safety mechanism raise the platform by about 3cm and lift the locking frame sufficiently to allow the cam to rotate so that its flat side is upwards. See fig.5. This raises the height of the locking frame and allows it to pass over the stop point as the platform is lowered.
- 5.2.5. Slowly operate the decent valve on the pump ( see fig1.9 ) in order to lower the platform.
- 5.2.6. As the platform continues to lower, the safety cam will automatically rotate back to the safety position. As the locking frame approaches the next stop point it will be necessary to stop the descent and rotate the cam again by lifting the locking frame.
- 5.2.7. When the platform has fully descended, release/unchock the tractor and back it off the platform using the brakes to control its progress.

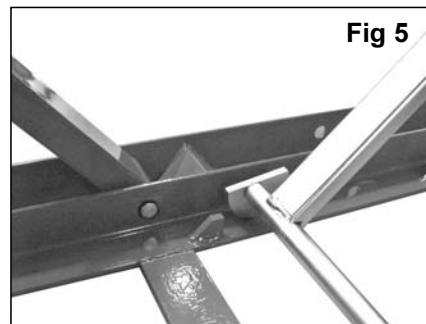

## 6. TROUBLESHOOTING

PROBLEM	POSSIBLE CAUSE	REMEDY
1. The lift vibrates during raising and lowering.	Air bubbles present in the system.	Top up oil if low. Bleed the system (see section 4.4).
2. The lift stops during descent.	Safety device engaged.	Disengage safety device. ( See section 5.2.4 )
3. Foot pump operates but platform does not rise.	Load exceeds capacity. Lowering valve not fully closed.	Cannot lift loads in excess of 700kg. Close lowering valve. ( See fig1.9 )
4. The lift will not descend.	The flexible pipe is blocked or the flow regulator is blocked.	Secure the lift so that it cannot lower using suitable and safely placed props. Remove flexible pipe from pump and piston and remove blockage.
5. Descent is too slow	Oil is too thick	Replace oil with new Sealey hydraulic oil

## 7. MAINTENANCE & CLEANING

**IMPORTANT: NO RESPONSIBILITY IS ACCEPTED FOR INCORRECT USE OF THE LIFT.**

**DO NOT USE THE LIFT IF IT IS BELIEVED TO HAVE BEEN SUBJECTED TO ABNORMAL SHOCK OR LOAD. INSPECT AND TAKE APPROPRIATE ACTION.**

**7.1. CLEANING** Cleaning must be carried out by operators who have been trained in how to raise and lower the lift with particular attention being given to the engagement of the anti lowering safety device.

7.1.1. The machine should be wiped clean with a clean, dry cloth. Do not use water, solvents or any flammable liquids.

### 7.2. MAINTENANCE

**WARNING! Only a good quality hydraulic oil, such as SEALEY HYDRAULIC JACK OIL must be used, DO NOT use brake fluid.**

7.2.1. Before each use, ensure components are not damaged, malfunctioning or missing. If any suspect item is found remove the lift from service and take the necessary action to remedy the problem.

7.2.2. When the lift is not in use, the platform must be in the lowest position to minimise hydraulic ram and piston corrosion.

7.2.3. Periodically check the pump piston and piston rod for signs of corrosion. Clean exposed areas with a clean oiled cloth.

7.2.4. Lubricate all moving parts on a regular basis. Wipe off any excess of oil or grease.

*Hydraulic products are only repaired by local service agents. We have service/repair agents in all parts of the UK. **DO NOT RETURN LIFTS TO US.** Please telephone 01284 757500 to obtain address and 'phone number of your local agent. If lift is under guarantee please contact your dealer.*

**De-commissioning:** If and when the lift become completely unserviceable, draw off the oil into an approved container and dispose of the lift and the oil according to local regulations.

## 8. DECLARATION OF CONFORMITY

**Declaration of Conformity** We, the sole importer into the UK, declare that the product listed below is in conformity with the following standards and directives.

**Mini Tractor Lift**

**Model: MT700**

98/37/EC Machinery Directive  
93/68/EEC CE Marking Directive



The construction file for this product is held by the Manufacturer and may be inspected, by a national authority, upon request to Jack Sealey Ltd.

Signed by Mark Sweetman

4th May 2004

*For Jack Sealey Ltd. Sole importer into the UK of Sealey Quality Machinery.*

**NOTE:** It is our policy to continually improve products and as such we reserve the right to alter data, specifications and component parts without prior notice.

**IMPORTANT:** No liability is accepted for incorrect use of this product.

**WARRANTY:** Guarantee is 12 months from purchase date, proof of which will be required for any claim.

**INFORMATION:** For a copy of our latest catalogue and promotions call us on 01284 757525 and leave your full name and address, including postcode.



Sole UK Distributor  
Sealey Group,  
Bury St. Edmunds, Suffolk.

01284 757500  
01284 703534

[www.sealey.co.uk](http://www.sealey.co.uk)  
[sales@sealey.co.uk](mailto:sales@sealey.co.uk)