

SEALEY

SANDER/POLISHER Ø170MM 6-SPEED 1300W/230V WITH SCHUKO PLUG MODEL NO: MS900PSEU

Thank you for purchasing a Sealey product. Manufactured to a high standard, this product will, if used according to these instructions, and properly maintained, give you years of trouble free performance.

IMPORTANT: PLEASE READ THESE INSTRUCTIONS CAREFULLY. NOTE THE SAFE OPERATIONAL REQUIREMENTS, WARNINGS & CAUTIONS. USE THE PRODUCT CORRECTLY AND WITH CARE FOR THE PURPOSE FOR WHICH IT IS INTENDED. FAILURE TO DO SO MAY CAUSE DAMAGE AND/OR PERSONAL INJURY AND WILL INVALIDATE THE WARRANTY. KEEP THESE INSTRUCTIONS SAFE FOR FUTURE USE.



Refer to instructions



Wear eye protection



Wear protective gloves



Wear a mask



Wear protective clothing



Wear ear protection

1. SAFETY

1.1. ELECTRICAL SAFETY

- ❑ **WARNING!** It is the user's responsibility to check the following:

Check all electrical equipment and appliances to ensure that they are safe before using. Inspect power supply leads, plugs and all electrical connections for wear and damage. Sealey recommend that an RCD (Residual Current Device) is used with all electrical products. You may obtain an RCD by contacting your local Sealey stockist.

if the multi-tool is used in the course of business duties, it must be maintained in a safe condition and routinely PAT (Portable Appliance Test) tested.

Electrical safety information. It is important that the following information is read and understood.

- 1.1.1. Ensure that the insulation on all cables and on the appliance is safe before connecting it to the power supply.

- 1.1.2. Regularly inspect power supply cables and plugs for wear or damage and check all connections to ensure that they are secure.

Important: Ensure that the voltage rating on the appliance suits the power supply to be used and that the plug is fitted with the correct fuse - see fuse rating in these instructions.

- ✗ **DO NOT** pull or carry the appliance by the power cable.

- ✗ **DO NOT** pull the plug from the socket by the cable. Remove the plug from the socket by maintaining a firm grip on the plug.

- ✗ **DO NOT** use worn or damaged cables, plugs or connectors. Ensure that any faulty item is repaired or replaced immediately by a qualified electrician.

- 1.1.3. This product is fitted with a Schuko plug.

If the cable or plug is damaged during use, switch off the electricity supply and remove from use.

Replace a damaged plug with an appropriate plug. If in doubt contact a qualified electrician.

Class II products are wired with live (brown) and neutral (blue) only are marked with the Class II symbol; 

A) Connect the BROWN live wire to the live terminal 'L'.

B) Connect the BLUE neutral wire to the neutral terminal 'N'.

C) After wiring, check that there are no bare wires and ensure that all wires have been correctly connected.

Ensure that the cable outer sheath extends inside the cable restraint and that the restraint is tight.

- ✗ **DO NOT** connect either wire to the earth terminal.

Sealey recommend that repairs are carried out by a qualified electrician.

- ✗ **DO NOT** use worn or damaged leads, plugs or connections. Immediately replace or have repaired by a qualified electrician.

Cable extension reels. When a cable extension reel is used it should be fully unwound before connection. A cable reel with an RCD fitted is recommended since any product which is plugged into the cable reel will be protected. The section of the cores of the cable is important. We suggest 1.5mm² section as a minimum but to be absolutely sure that the capacity of the cable reel is suitable for this product and for others that may be used in the other output sockets, we recommend the use of 2.5mm² section cable.

NOTE: The MS900PSEU has an electronic speed control, which requires a 'clean' and stable power supply. Normal 230V mains supply is suitable. However, the output from many petrol driven generators may not be suitable for this tool. 'Inverter' type power supplies provide a much more stable output, and should present no problem.

1.2. GENERAL SAFETY

- ❑ **WARNING!** Ensure Health & Safety, local authority, and general workshop practice regulations are adhered to when using this equipment.

- ✓ Familiarise yourself with the application and limitations of the product, as well as the specific potential hazards peculiar to the polisher.

- ❑ **WARNING!** Disconnect from the mains power and ensure the disc is at a complete standstill before changing accessories, servicing or performing any maintenance.

- ✓ Maintain the polisher/sander in good condition (use an authorised service agent).

- ✓ Replace or repair damaged parts. *Use genuine parts only. Non-authorised parts may be dangerous and will invalidate the warranty.*

- ❑ **WARNING!** Keep all guards and holding screws in place, tight and in good working order. Check regularly for damaged parts. A guard or any other part that is damaged must be repaired/replaced before the tool is next used.

- ✓ Locate polisher/sander in a suitable working area, keep area clean and tidy and free from unrelated materials. Ensure there is adequate lighting.

- ✓ Keep the polisher/sander clean for best and safest performance.

- ✓ Before each use check abrasive attachments for condition. If worn or damaged replace immediately.

- ✓ Ensure there are no flammable or combustible materials near the work area.

- ❑ **WARNING!** Wear approved eye safety protection, ear defenders and, if dust is generated, respiratory protection.

- ✓ Maintain correct balance and footing. Ensure the floor is not slippery and wear non-slip shoes.

- ✓ Remove ill fitting clothing. Remove ties, watches, rings, and other loose jewellery, and contain and/ or tie back long hair.

- ✓ Keep children and unauthorised persons away from the working area.

- ✓ Secure non-stable work piece with a clamp, vice or other adequate holding device.
- ✓ Remove adjusting keys and wrenches from the machine and its vicinity before turning it on.
- ✗ **DO NOT** use equipment for any purpose other than that for which it is designed.
- ✗ **DO NOT** operate the polisher/sander if any parts are damaged or missing as this may cause failure or possible personal injury.
- **WARNING! DO NOT** sand any materials containing asbestos.
- ✗ **DO NOT** switch the polisher/sander on whilst the head is in contact with the work piece and avoid unintentional starting.
- ✗ **DO NOT** get the polisher/sander wet or use in damp or wet locations or areas where there is condensation.
- ✗ **DO NOT** allow untrained persons to operate the polisher/sander.
- ✗ **DO NOT** operate the polisher/sander when you are tired, under the influence of alcohol, drugs or intoxicating medication.
- ✗ **DO NOT** use the polisher/sander where there are flammable liquids, solids or gases such as paint solvents, etc.
- ✗ **DO NOT** leave the polisher/sander operating unattended.
- ✗ **DO NOT** carry the polisher/sander with your finger on the power switch.
- ✗ **DO NOT** pull the cord to remove the plug from the power supply.
- ✓ Use a qualified person to lubricate and maintain the polisher/sander.
- ✓ When not in use unplug from the mains power supply and store in a safe, dry, childproof area.

LEAD PAINT WARNING! Paint once contained lead as a traditional ingredient. Contact with the dust from the removal of such paint is toxic and must therefore be avoided. The following action must be taken before using machine as a sander:

1. User must determine potential hazard relating to age of paint to be removed. (Modern paints do not have lead content).
2. **DANGER!** Keep all persons and pets away from the working area. The following are particularly vulnerable to the effects of lead paint dust: Expectant women, babies and children.
3. We recommend personal protection by using the following safety items:
A) Paint Spray Respirator (Sealey ref. SSP1699) B) PE Coated Hooded Coverall (Sealey ref. SSP266). C) Latex Gloves (Sealey ref. SSP24).
4. Take adequate measures to contain paint dust, flakes and scrapings. Wear safety equipment, as in (3) above and thoroughly clean all areas when task is complete.
5. Ensure the paint waste is disposed of in sealed bags or containers according to local regulations.

2. INTRODUCTION

Features six speed power control suitable for sanding and polishing. Speeds range from 1400 to 3000rpm. Alloy bevel gear head with composite motor housing. Supplied with Ø170mm backing pad and side handle. Fitted with Schuko Plug.

3. SPECIFICATION

Model no	MS900PSEU
Free speed	1000-3000rpm
Motor power	1300W
Supply	230V - 5.8A
Pad size	Ø170mm
Thread size	M14 x 2mm
Noise power	92dBA
Noise pressure	81dBA
Vibration	7.678m/s ²
Uncertainty	1.5m/s ²

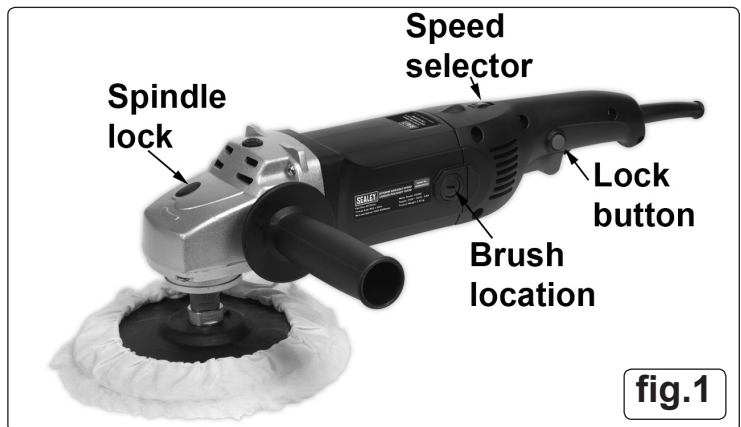

4. ASSEMBLY

- **WARNING!** Ensure the unit is not plugged into the mains supply before attempting assembly.

4.1. Attach the side handle.

Note: there is a mounting hole on either side and the top to suit the application and/or operator.

4.1.1. To attach the rubber pad, fig.2:

Thread the rubber pad on shaft (S) and tighten using spanner by holding shaft steady with spindle lock.

4.1.2. To fit a sanding disc, fig.2:

Select the grade of self adhesive sanding disc required (D), peel off the backing and centrally locate the disc onto the rubber pad.

4.1.3. To fit a polishing bonnet, fig.3:

Fit the polishing bonnet (Z) over the secured rubber pad, using the pull cord, tighten the bonnet and tie a bow to secure, tuck the loose ends of the bow neatly under the bonnet.

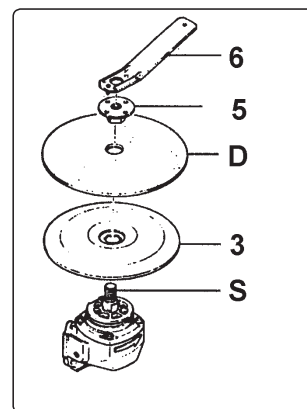

fig.2

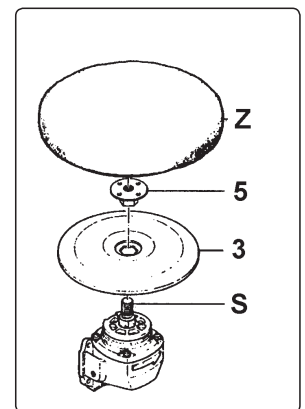

fig.3

5. OPERATION

- **WARNING!** Ensure you read, understand and apply the safety instructions in Section 1.
- **WARNING!** The warnings, cautions and instructions discussed in this manual cannot cover all possible conditions and situations that may occur. It must be understood that common sense and caution are factors which cannot be built into this product, but must be applied by the operator.

5.1. Ensure the power control switch is NOT locked on before plugging into the mains.

5.2. Hold the polisher firmly with one hand on the handle grip and the other on the side handle. To select the required speed rotate the speed selector switch, fig.1, to the required speed 1 to 6.

Speed Settings: Range from 1000rpm - 3000rpm

- 5.3. To start the polisher press and hold in the safety lock button (fig.5.1) and squeeze the trigger. When releasing the trigger, the safety lock button will engage, preventing the polisher from being inadvertently started.

WARNING! The high speed settings are intended for sanding. If used for polishing an excessive amount of surface material may be removed.

Note: As the rubber support disc is flexible, when sanding it should not be used head on, but at an angle of approximately 10 to 20 degrees.

Contact your Sealey stockist for details of compound heads and lambs wool bonnets.

6. MAINTENANCE

- WARNING!** Before attempting any maintenance ensure the unit is unplugged from the mains power supply.
- 6.1. Keep the machine clean and dry. **DO NOT** use abrasives or solvents to clean the unit. Ensure all external head screws are tight.
- 6.2. Clean regularly by blowing a jet of compressed air through side vents to ensure motor ventilation is kept clear.
- WARNING!** Wear approved safety eye protection and, if necessary, respiratory protection.
- Note:** The following maintenance must only be carried out by a suitably qualified person or an authorised Sealey service agent.
- 6.3. Check carbon brushes by removing each side screw, fig.1. Check to see if the brushes are worn or cracked. If so, the brushes must be replaced to avoid sparking and damage to the armature. Always change brushes as a pair. Use only genuine spare parts as these are specifically designed for the machine. Failure to do so may be dangerous and will invalidate your warranty.
- 6.4. After each 500 hours of use replace the gear head grease to prevent gear wear and possible drive failure.

WARNING! - Risk of Hand Arm Vibration Injury.

This tool is subject to the vibration testing section of the Machinery Directive 2006/42/EC. When operated in accordance with these instructions and tested in accordance with the standard below, results in the following vibration emission declared in accordance with EN 12096:1997

Model No: MS900PSEU Sander/ Polisher

Tested in Accordance with: BS EN ISO 28927-3:2009

Measured Vibration Emission Value (a): 7.678m/s²

Uncertainty value (k): 1.5m/s²

These values are suitable for comparison with the vibration emission levels of other tools that have been obtained using the same test method.

This tool may cause hand-arm vibration syndrome if its use is not adequately managed.

A health and safety assessment by the user (or employer) will need to be carried out to determine the suitable duration of use for each tool. Note that the value declared is an average figure from a series of tests according to the applicable standard. The value may differ depending on a number of variables including but not limited to; the user; the condition of the tool; attachments made to the tool i.e. sockets, grinding/cutting discs, sanding discs, blades, handles and leader hoses.

Health surveillance.

We recommend a programme of health surveillance to detect early symptoms of vibration injury so that management procedures can be modified to help prevent significant handicap.

Personal protective equipment.

We are not aware of any personal protective equipment (PPE) that provides protection against vibration injury by attenuating the vibration emissions of this tool. We recommend a sufficient supply of clothing (including gloves) to enable the operator to remain warm and dry and maintain good blood circulation in fingers etc.

Guidance relating to the management of hand arm vibration can be found on the HSC website www.hse.gov.uk – Hand-Arm Vibration at Work.



WEEE REGULATIONS

Dispose of this product at the end of its working life in compliance with the EU Directive on Waste Electrical and Electronic Equipment (WEEE). When the product is no longer required, it must be disposed of in an environmentally protective way. Contact your local solid waste authority for recycling information.



ENVIRONMENT PROTECTION

Recycle unwanted materials instead of disposing of them as waste. All tools, accessories and packaging should be sorted, taken to a recycling centre and disposed of in a manner which is compatible with the environment. When the product becomes completely unserviceable and requires disposal, drain any fluids (if applicable) into approved containers and dispose of the product and fluids according to local regulations.

Note: It is our policy to continually improve products and as such we reserve the right to alter data, specifications and component parts without prior notice.

Important: No Liability is accepted for incorrect use of this product.

Warranty: Guarantee is 12 months from purchase date, proof of which is required for any claim.

Sealey Group, Kempson Way, Suffolk Business Park, Bury St Edmunds, Suffolk. IP32 7AR



01284 757500



01284 703534



sales@sealey.co.uk



www.sealey.co.uk