

Thank you for purchasing a Sealey product. Manufactured to a high standard this product will, if used according to these instructions and properly maintained, give you years of trouble free performance.



**IMPORTANT: PLEASE READ THESE INSTRUCTIONS CAREFULLY. NOTE THE SAFE OPERATIONAL REQUIREMENTS, WARNINGS & CAUTIONS. USE THE PRODUCT CORRECTLY AND WITH CARE FOR THE PURPOSE FOR WHICH IT IS INTENDED. FAILURE TO DO SO MAY CAUSE DAMAGE AND/OR PERSONAL INJURY AND WILL INVALIDATE THE WARRANTY. PLEASE KEEP INSTRUCTIONS SAFE FOR FUTURE USE.**

## 1. SAFETY INSTRUCTIONS

### 1.1 GENERAL SAFETY

- ❑ **WARNING!** Ensure Health & Safety, local authority, and general workshop practice regulations are adhered to when using this equipment.
- ✓ Maintain the wheel alignment tool in good condition.
- ✓ Replace or repair damaged parts. Use genuine parts only. Non-authorised parts may be dangerous and will invalidate the warranty.
- ✓ Locate wheel alignment tool in a suitable working area, keep area clean and tidy and free from unrelated materials.
- ❑ **WARNING!** Ensure that the motorcycle is on a stable stand located on level and solid ground.
- ✓ Keep the gauge scales clean to ensure accurate performance.
- x **DO NOT** use outside in damp or wet weather conditions.
- x **DO NOT** allow untrained persons to operate the aligner.
- x **DO NOT** leave the alignment tool unattended.
- ❑ **WARNING!** The warnings, cautions and instructions contained within this document cannot cover all possible conditions and situations that may occur. It must be understood that common sense and caution are factors which cannot be built into this product, but must be applied by the operator.
- ✓ Any alignment changes deemed necessary as a result of using this equipment must be made strictly in accordance with the motorcycle manufacturer's recommendations.

### 1.2 LASER SAFETY

The MS070 utilises a Class 2M laser that emits low levels of visible radiation light (i.e. wavelengths between 630 and 640 nanometres) which are safe for the skin but not inherently safe for the eyes. The Class 2M emission limit is set at the maximum level for which eye protection is normally afforded by natural aversion responses to bright light. Accidental eye exposure is therefore normally safe, although the natural aversion response can be overridden by deliberately staring into the beam, and can also be influenced by the use of alcohol or drugs.



- ❑ **WARNING!** Do not look or stare into the laser beam as permanent eye damage could result.
- x **DO NOT** direct the laser beam at any person's (or animal's) eyes as eye damage could result. If the beam is obstructed by a person during use, release the contact switch immediately.
- x **DO NOT** use the equipment while under the influence of alcohol, drugs or whilst on medication.
- ✓ Be aware that reflections of the laser beam from mirrors or other shiny surfaces can be as hazardous as direct eye exposure.

## 2. INTRODUCTION

Fast, simple and accurate alignment of rear wheel. Optimises vehicle performance and set up after installation or modification of the chain, sprockets, brakes or suspension components. This fully portable kit is also ideal for track-day set up or for the motorcycle enthusiast.

## 3. SET-UP

- 3.1 **Laser Power:** The laser units are battery powered and require two AA batteries in each battery box. See fig.2.
- 3.1.1 Slide back the lid on each box and insert the batteries paying attention to the polarity markings in the base of each box. Slide the lids back into position on each battery box.

- 3.1.2 Ensure the laser units are working by switching on with the units directed to the ground. Switch off after testing.
- 3.2 **Assembly:** Identify the laser unit with the threaded insert in the side and screw one of the threaded rods supplied into the insert. Identify the scale unit with the threaded insert in the side and screw the other threaded rod into place.
- 3.3 **Motorcycle stability:** Before attaching the laser and scale units you must ensure that the motorcycle is adequately supported on a suitable stand that lifts the rear wheel from the ground and supports the motorcycle in a perpendicular orientation. The stand must also be on a firm stable surface such as concrete.
- 3.4 **Attaching the laser units to the rear wheel:** Referring to fig.1, loosen the clamp and remove the clamp unit and spring from the rod together with the right hand laser unit. Position the left hand laser unit with the rod attached on the nearside

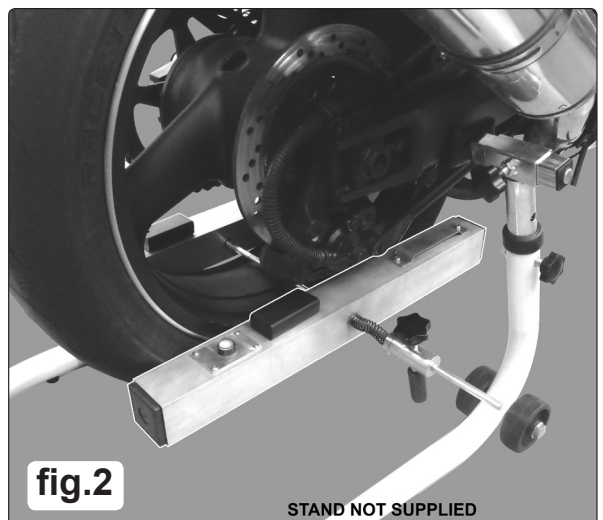
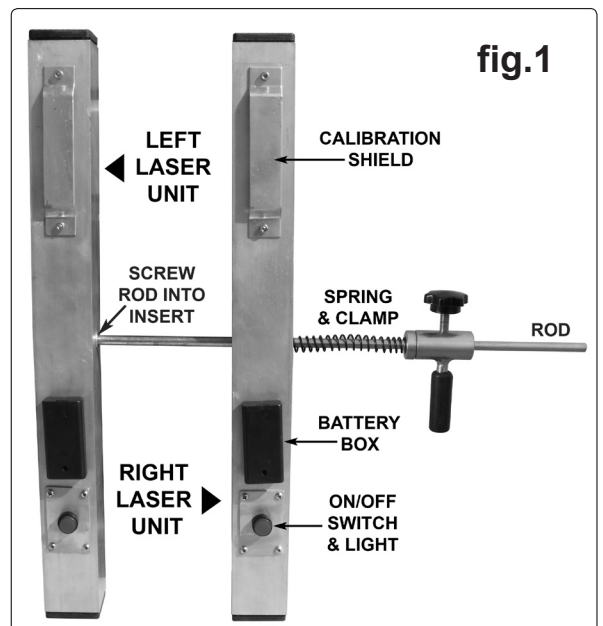

of the rear wheel and insert the rod through the lower part of the wheel. Slide the right hand laser unit onto the rod and up to the tyre, followed by the spring and clamp unit. Lightly clamp the two units to the tyre in the position indicated in fig.2.

**3.5 Attaching the scale units to the front wheel:** Referring to fig.3, loosen the clamp and remove the clamp unit and spring from the rod together with the right hand scale unit. Position the left hand scale unit with the rod attached on the nearside of the front wheel in a near vertical orientation and insert the rod through the front part of the wheel. Slide the right hand scale unit onto the rod and up to the tyre, followed by the spring and clamp unit. Ensure that the two scale units are parallel to each other and then firmly clamp them to the tyre in the position indicated in fig.4.

**3.5.1** Switch on the lasers and note the position of each beam on the scales. If necessary, adjust the position/angle of the laser units on the rear wheel to get the beams to appear on the scales.

**3.6 Front wheel position:** The front wheel must be in the straight ahead position before accurate alignment can take place. If the beams are parallel with the scale lines the front wheel is set dead ahead. If the beams are at an angle to the scale lines, turn the wheel one way or the other until they are parallel.

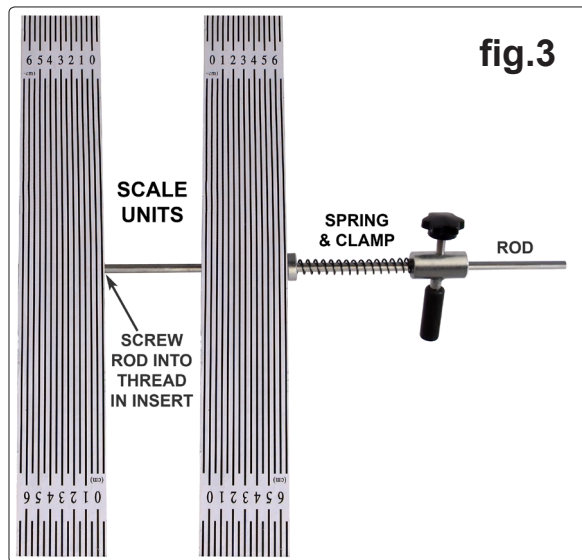

#### 4. ALIGNMENT PROCEDURE

**4.1 Alignment procedure:** Compare the readings on the scales. If they are the same then the rear wheel is in alignment with the front wheel. If they are not the same then it will be necessary to operate the rear wheel adjusters. If the reading is higher on the right hand scale, tighten the left hand adjuster. If the reading is higher on the left hand scale, tighten the right hand adjuster. When the wheels are in alignment, finally tighten the rear wheel axle fixings.

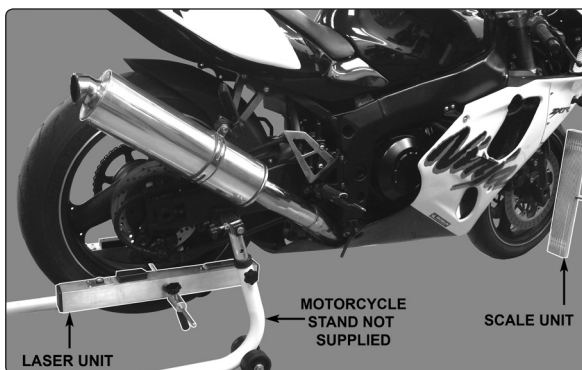
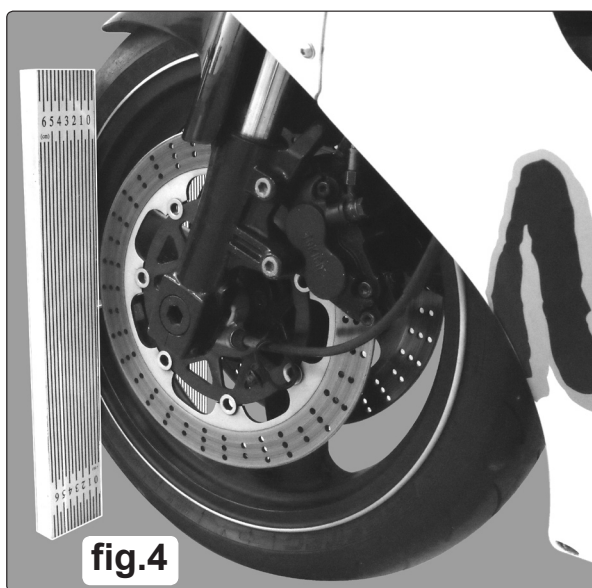

Parts support is available for this product. To obtain a parts listing and/or diagram, please log on to [www.sealey.co.uk](http://www.sealey.co.uk), email [sales@sealey.co.uk](mailto:sales@sealey.co.uk) or phone 01284 757500.



**Environmental Protection.**  
Recycle unwanted materials instead of disposing of them as waste. All tools, accessories and packaging should be sorted, taken to a recycle centre and disposed of in a manner which is compatible with the environment.



When the product is no longer required, it must be disposed of in an environmentally protective way. Contact your local solid waste authority for recycling information.



**Battery Removal.**  
1. Slide back and remove the lid from each battery box mounted on each laser unit.  
2. Remove the 2 AA batteries from each box and dispose of the batteries according to local authority guidelines.

Under the Waste Batteries and Accumulators Regulations 2009, Jack Sealey Ltd are required to inform potential purchasers of products containing batteries (as defined within these regulations), that they are registered with Valpak's registered compliance scheme.  
Jack Sealey Ltd's Batteries Producer Registration Number (BPRN) is BPRN00705

**NOTE:** It is our policy to continually improve products and as such we reserve the right to alter data, specifications and component parts without prior notice.

**IMPORTANT:** No liability is accepted for incorrect use of this product.

**WARRANTY:** Guarantee is 12 months from purchase date, proof of which will be required for any claim.

**INFORMATION:** For a copy of our latest catalogue and promotions call us on 01284 757525 and leave your full name and address, including postcode.



**Sole UK Distributor, Sealey Group,**  
Kempson Way, Suffolk Business  
Park, Bury St. Edmunds, Suffolk,  
IP32 7AR



01284 757500



01284 703534



[www.sealey.co.uk](http://www.sealey.co.uk)



[sales@sealey.co.uk](mailto:sales@sealey.co.uk)