



FORK SEAL DRIVER Ø45-54MM

MODEL NO: **MS0161.V2**

Thank you for purchasing a Sealey product. Manufactured to a high standard, this product will, if used according to these instructions, and properly maintained, give you years of trouble free performance.

IMPORTANT: PLEASE READ THESE INSTRUCTIONS CAREFULLY. NOTE THE SAFE OPERATIONAL REQUIREMENTS, WARNINGS & CAUTIONS. USE THE PRODUCT CORRECTLY AND WITH CARE FOR THE PURPOSE FOR WHICH IT IS INTENDED. FAILURE TO DO SO MAY CAUSE DAMAGE AND/OR PERSONAL INJURY AND WILL INVALIDATE THE WARRANTY. KEEP THESE INSTRUCTIONS SAFE FOR FUTURE USE.



Refer to instruction manual



Wear protective gloves

1. SAFETY

- × **DO NOT** use the driver for a purpose it is not designed to perform.
- × **DO NOT** use the driver if it is damaged, it could scratch the stanchion.
- × **DO NOT** make any modifications to the driver.
- ✓ Maintain the driver in a good clean condition for the best and safest performance.
- ✓ When not in use, store in a dry location.

2. INTRODUCTION

Designed for easy installation of fork seals. Limits potential damage caused by other installation methods to the forks. Made from high strength Carbon Steel. The split design ensures that the new front fork seal will not be damaged during installation. Heavy-duty body and a four pronged collet, it will evenly press the seal into the front fork tube. Minimum/Maximum Fork Diameter: Ø45-54mm.

3. SPECIFICATION

Model No.:**MS0161**
Max. / Min. Fork diameterØ45 - Ø54 mm

4. ASSEMBLY

Always refer to the original manufacturer's manual for assembly/dissassembly of the motorcycle fork seals.

4.1. COLLET ORIENTATION (Refer to fig.3, fig.4).

- 4.1.1. Measure the stanchion diameter (Ø"A") and the seal ring outer diameter. Determine the required engagement diameter of the collet (Ø"B") to the seal ring and hence its orientation in order to obtain full seal ring insertion (fig.3 and fig.4). It is recommended that the collet diameter (Ø"B") is slightly less than the maximum seal diameter in order to allow for full seal ring insertion.

4.1.2. Lightly lubricate the stanchion, slip on the new seal ring and slide it down to the slider housing.

4.1.3. From section 4.1.1 and figs.3 and 4, decide on the correct collet set up (e.g. collet orientation) and slide it onto the stanchion.

4.2. SLIDE HAMMER

4.2.1. In fig.3 and fig.4 the pins in the slide hammer will be engaged with opposing holes of the other half of the hammer however it may be such that the engagement between the pins and holes will be lost (fig.5). In these circumstances it will be necessary to align the two halves of the slide hammer by eye in order to obtain even pressure and thus correctly aligned seal ring insertion.

4.2.2. Holding the slide hammer halves together press the seal into the slider housing. Replace seal retaining ring if required and repeat all tasks with the other fork.



fig.1



fig.2

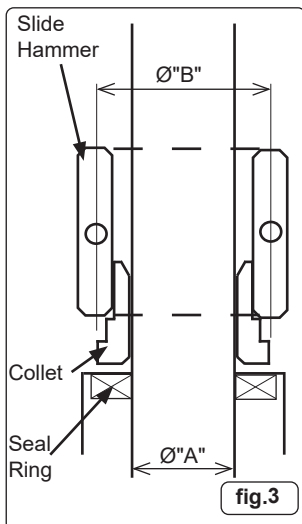

fig.3

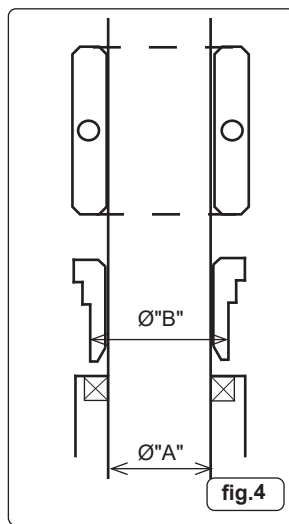

fig.4

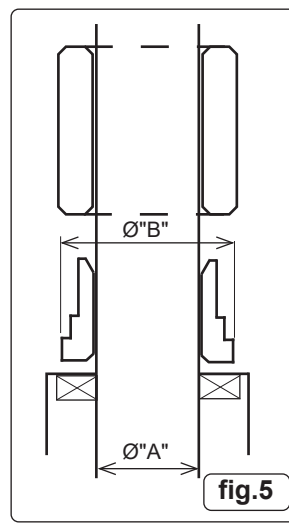

fig.5



ENVIRONMENT PROTECTION

Recycle unwanted materials instead of disposing of them as waste. All tools, accessories and packaging should be sorted, taken to a recycling centre and disposed of in a manner which is compatible with the environment. When the product becomes completely unserviceable and requires disposal, drain any fluids (if applicable) into approved containers and dispose of the product and fluids according to local regulations.

Note: It is our policy to continually improve products and as such we reserve the right to alter data, specifications and component parts without prior notice. Please note that other versions of this product are available. If you require documentation for alternative versions, please email or call our technical team on technical@sealey.co.uk or 01284 757505.

Important: No Liability is accepted for incorrect use of this product.

Warranty: Guarantee is 12 months from purchase date, proof of which is required for any claim.

Sealey Group, Kempson Way, Suffolk Business Park, Bury St Edmunds, Suffolk. IP32 7AR



01284 757500



sales@sealey.co.uk



www.sealey.co.uk