

Thank you for purchasing a Sealey product. Manufactured to a high standard this product will, if used according to these instructions and properly maintained, give you years of trouble free performance.



IMPORTANT: PLEASE READ THESE INSTRUCTIONS CAREFULLY. NOTE THE SAFE OPERATIONAL REQUIREMENTS, WARNINGS AND CAUTIONS. USE THE PRODUCT CORRECTLY AND WITH CARE FOR THE PURPOSE FOR WHICH IT IS INTENDED. FAILURE TO DO SO MAY CAUSE DAMAGE AND/OR PERSONAL INJURY AND WILL INVALIDATE THE WARRANTY. PLEASE KEEP INSTRUCTIONS SAFE FOR FUTURE USE.

1. SAFETY INSTRUCTIONS

1.1. ELECTRICAL SAFETY

WARNING! It is the responsibility of the owner and the operator to read, understand and comply with the following:

You must check all electrical products, before use, to ensure that they are safe. You must inspect power cables, plugs, sockets and any other connectors for wear or damage. You must ensure that the risk of electric shock is minimised by the installation of appropriate safety devices. A Residual Current Circuit Breaker (RCCB) should be incorporated in the main distribution board. We also recommend that a Residual Current Device (RCD) is used. It is particularly important to use an RCD with portable products that are plugged into a supply which is not protected by an RCCB. If in any doubt consult a qualified electrician. You may obtain a Residual Current Device by contacting your Sealey dealer.

You must also read and understand the following instructions concerning electrical safety.

- 1.1.1. The **Electricity at Work Act 1989** requires all portable electrical appliances, if used on business premises, to be tested by a qualified electrician, using a Portable Appliance Tester (PAT), at least once a year.
- 1.1.2. The **Health & Safety at Work Act 1974** makes owners of electrical appliances responsible for the safe condition of those appliances and the safety of the appliance operators. **If in any doubt about electrical safety, contact a qualified electrician.**
- 1.1.3. Ensure that the insulation on all cables and on the appliance is safe before connecting it to the power supply. See 1.1.1. and 1.1.2. and use a Portable Appliance Tester.
- 1.1.4. Ensure that cables are always protected against short circuit and overload.
- 1.1.5. Regularly inspect power supply cables and plugs for wear or damage and check all connections to ensure that none is loose.
- 1.1.6. **Important:** Ensure that the voltage marked on the appliance matches the power supply to be used and that the plug is fitted with the correct fuse - see fuse rating at right.
- 1.1.7. **DO NOT** pull or carry the appliance by the power cable.
- 1.1.8. **DO NOT** pull the plug from the socket by the cable.
- 1.1.9. **DO NOT** use worn or damaged cables, plugs or connectors. Immediately have any faulty item repaired or replaced by a qualified electrician. When an ASTA/BS approved UK 3 pin plug is damaged, cut the cable just above the plug and **dispose of the plug safely**. Fit a new plug according to the following instructions (UK only).

- a) **Connect the GREEN/YELLOW earth wire to the earth terminal 'E'.**
- b) **Connect the BROWN live wire to the live terminal 'L'.**
- c) **Connect the BLUE neutral wire to the neutral terminal 'N'.**
- d) **After wiring, check that there are no bare wires, that all wires have been correctly connected, that the cable outer insulation extends beyond the cable restraint and that the restraint is tight.**

Double insulated products, which are always marked with this symbol , are fitted with live (brown) and neutral (blue) wires only. To rewire, connect the wires as indicated above - **DO NOT** connect either wire to the earth terminal.

- 1.1.10. This product is supplied without a plug fitted. To fit a plug, follow the instructions detailed in paragraph 1.1.9.
- 1.1.11. If an extension reel is used it should be fully unwound before connection. A reel with an RCD fitted is preferred since any appliance plugged into it will be protected. The cable core section is important and should be at least 1.5mm², but to be absolutely sure that the capacity of the reel is suitable for this product and for others which may be used in the other output sockets, we recommend the use of 2.5mm² section cable. If extension reel is to be used outdoors, ensure it is marked for outdoor use.

1.2. GENERAL SAFETY INSTRUCTIONS

- ✓ Familiarise yourself with the application and limitations of the panel dryer.
- ✓ Ensure the panel dryer is in good order and condition before use. If in any doubt do not use the unit and contact an electrician.
- ✓ Only use recommended attachments and parts. To use unauthorised items may be dangerous and will invalidate your warranty.
- ✓ Use the panel dryer with post in the vertical position only and ensure it is placed on a firm, level floor.
- ✓ Check that the lamp guard is in place, undamaged and firmly attached.
- ✓ Keep tools and other items away from the panel dryer when it is in use.
- ✓ Keep the work area clean and clear of unnecessary items.
- ✓ Keep children and unauthorised persons away from the work area.
- ✓ Remember that the lamp panel will get hot, allow to cool after use.
- x **DO NOT** dis-assemble the panel dryer for any reason. The panel dryer must be checked by qualified personnel only.
- x **DO NOT** use the panel dryer outdoors, or in damp, or wet locations and **DO NOT** operate within the vicinity of flammable liquids, gases or solids.
- x **DO NOT** use this product to perform a task for which it is not designed.
- **WARNING! If a fuse blows, ensure it is replaced with a fuse of identical type and rating.**
- ✓ When not in use, store the panel dryer carefully in a safe, dry, childproof location.

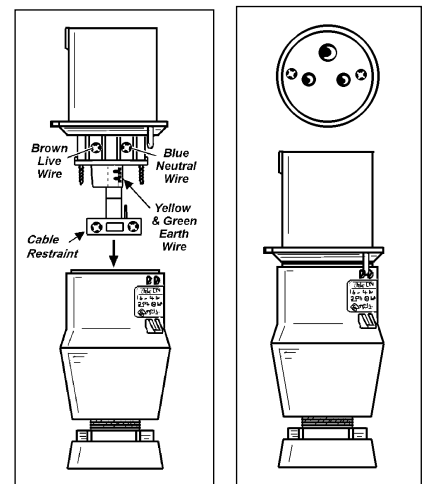

2. INTRODUCTION

The ML2251 Medium Wave Panel Dryer is fitted with a 1500W element which is controlled by a 0-30 minute timer. The drying element is adjustable for height and the dryer is mounted on wheels for stability and ease of movement.

3. ASSEMBLY

Note: Numbers in brackets refer to item numbers in fig 1.

- 3.1. Attach the stand (1) to base (2) using bolts, washers and nuts provided (3).
- 3.2. Fit the control unit support (4) onto the special pin (5) welded onto the base.
- 3.3. Fit the light fixture (6) onto the stand, adjust to the required height and secure in position using the locking knob (7).

Note: The light fixture has protective packaging which should not be removed until it has been fitted to the stand.

- 3.4. Remove the adhesive tape (13), and the front grille (14).
- 3.5. Remove the outer protective foam rubber packaging (16) and carefully pull out the two internal foam rubber protectors (18).

Note: GREAT CARE should be taken to avoid damaging the heating element (17).

- 3.6. Fit the front grille (14) and secure using the self tapping screws provided (15).
- 3.7. Connect the electrical plug (9) to the lamp socket (8).
- 3.8. Connect the supply plug (10) to the mains supply.

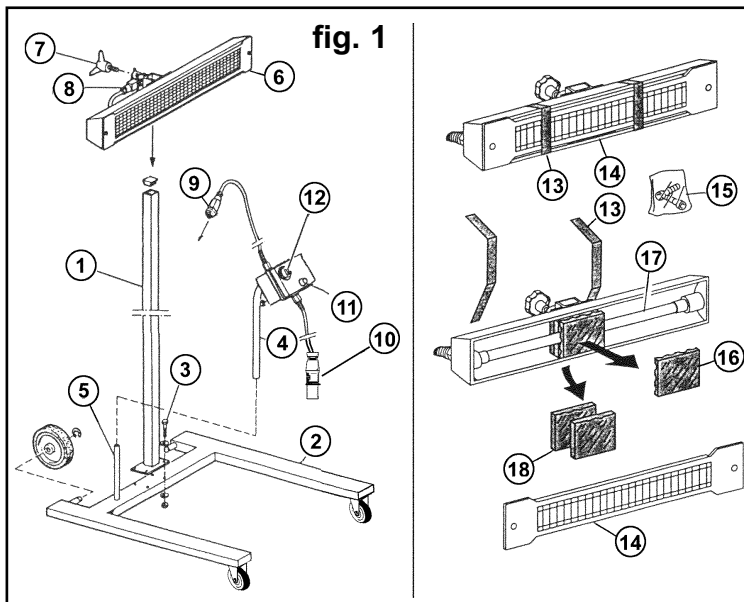

4. OPERATION

Note: The IR lamp is fragile and therefore it is important that the ML2251 is not subjected to any unnecessary shocks or vibration and is not moved when the lamp is switched on.

- WARNING! Ensure that you read, understand and apply the safety instructions in Section 1.**
- WARNING! Ensure that the foam rubber lamp protectors have been removed before switching on.**

- 4.1. Allow a 4 - 5 minute 'flash-off' period for excess solvent to evaporate before close positioning of lamp to panel - solvent boil or popping may occur if panel temperature is raised too rapidly. Remove, or otherwise protect, any trim items on, or adjacent to, the panel to prevent possible distortion.
- 4.2. Position the lamp approximately 500mm from the panel, ensuring that the knob (7) has been firmly tightened when the desired position has been achieved.
- 4.3. Paint-to-lamp distance and heating time are dependent on a number of factors including paint type and workshop conditions and are best based on experience, however guidelines are as follows:

Material	Drying Time	Distance
Polyester stopper	10 - 15mins	600 - 700mm
MS primer	19 - 23mins	500 - 600mm
Water-based filler paint	19 - 23mins	500 - 600mm
Finishing paint	23 - 31mins	400 - 500mm

Important: Excessive drying time will burn the paint and may distort the panel.

- 4.4. Set the required heating time on the timer, plug into the mains socket and switch on. The green warning light is illuminated when electrical power is applied to the unit.
- 4.5. When the heating period is over switch off at socket and then remove dryer plug.
- 4.6. Allow lamp and lamp panel to cool before moving the panel dryer to a safe, dry, childproof storage area.

5. DECLARATION OF CONFORMITY

Declaration of Conformity We, the sole UK importer, declare that the product listed below is in conformity with the following standards and directives. The construction file for this product is held by the Manufacturer and may be inspected, by a national authority, upon request to Jack Sealey Ltd.

MEDIUM WAVE PANEL DRYER
Model: ML2251
 73/23/EEC LV Directive
 89/336/EEC EMC Directive
 93/68/EEC CE Marking Directive



Signed by Mark Sweetman

26th March 2003

For Jack Sealey Ltd. Sole UK importer of Sealey Power Products.

NOTE: It is our policy to continually improve products and as such we reserve the right to alter data, specifications and component parts without prior notice.
IMPORTANT: No liability is accepted for incorrect use of this equipment.

WARRANTY: Guarantee is 12 months from purchase date, proof of which will be required for any claim.

INFORMATION: For a copy of our latest catalogue and promotions call us on 01284 757525 and leave your full name and address, including postcode.

SEALEY

POWER PRODUCTS

Sole UK Distributor,
 Sealey Group,
 Bury St. Edmunds, Suffolk.

01284 757500

01284 703534

e-mail sales@sealey.co.uk

www.sealey.co.uk