

Thank you for purchasing a Sealey Product. Manufactured to a high standard this product will, if used according to these instructions and properly maintained, give you years of trouble free performance.



IMPORTANT: PLEASE READ THESE INSTRUCTIONS CAREFULLY. NOTE THE SAFE OPERATIONAL REQUIREMENTS, WARNINGS AND CAUTIONS. USE THIS PRODUCT CORRECTLY AND WITH CARE FOR THE PURPOSE FOR WHICH IT IS INTENDED. FAILURE TO DO SO MAY CAUSE DAMAGE AND/OR PERSONAL INJURY AND WILL INVALIDATE THE WARRANTY. PLEASE KEEP INSTRUCTIONS SAFE FOR FUTURE USE.

1. SAFETY INSTRUCTIONS

1.1. GENERAL

☐ WARNING!

- x DO NOT turn on the lantern if the fluorescent tube is missing or not properly installed, as this could damage the circuit.
- x DO NOT allow children to use the lantern.
- x DO NOT use if the battery or the lantern casing is damaged.
- ✓ When not in use store the lantern in a safe, dry, childproof location.

1.2. BATTERY SAFETY INSTRUCTIONS

- x DO NOT store the lantern in locations where the temperature may exceed 104°F (40°C) such as outside sheds, above heaters, or metal buildings in summer.
- x DO NOT mix alkaline, standard (carbon-zinc) or rechargeable (nickel-cadmium) batteries
- ☐ **WARNING! DO NOT allow a leaking battery to come into contact with your skin. If you come into contact with battery fluid take immediate action:**
 - a) **Skin contact:** Wash immediately with soap and water
 - b) **Eye contact:** Flush eye immediately with cool, clean running water for at least 15 minutes and seek immediate professional medical attention.

2. INTRODUCTION & OPERATION

2.1. INTRODUCTION

- 2.1.1. Tough composite body with lamp cover and carry handle suitable for a variety of industrial, domestic and leisure applications. Requires 6 X 1.5V size "C" batteries.

2.2 OPERATING

- 2.2.1. Turn the lantern ON and OFF by turning the knob to the desired position.
- 2.2.2. When the light of the fluorescent tube starts to dim, the batteries should be changed, otherwise the tube will blacken.

3. MAINTENANCE

3.1. CHANGING THE FLUORESCENT TUBE

- 3.1.1. Remove the lamp cover (fig 1 A) by unscrewing counter-clockwise.
- 3.1.2. Remove the fluorescent tube holder (fig 2 A) by unlatching counter clockwise.
- 3.1.3. Remove both locking clips (fig 3 A) by inserting a small flat head screwdriver under the clips as indicated (fig 2 B) and lifting.
- 3.1.4. Move the retaining clips (fig 3 B) away from the fluorescent tube and remove the tube from the holder (fig 2 A). Replace with new 7W fluorescent tube, Sealey Part No ML109/B.
- 3.1.5. Reverse the above procedure to re-assemble.

3.2. CHANGING THE BATTERIES

- 3.2.1. Remove the bottom cover (fig 1 B) by releasing both side catches.
- 3.2.2. Remove the 6 batteries and replace with new ones following the polarity markings shown.
- 3.2.3. Replace the bottom cover and locate both side catches ensuring they "click".

Keep the spotlight clean. Do not use abrasives or solvents.

fig 1

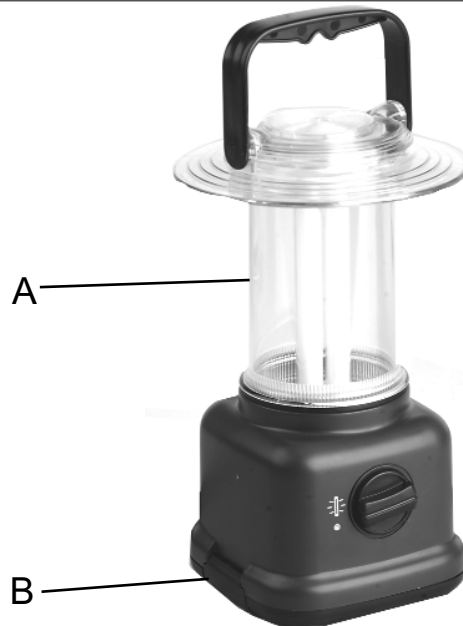

fig 2

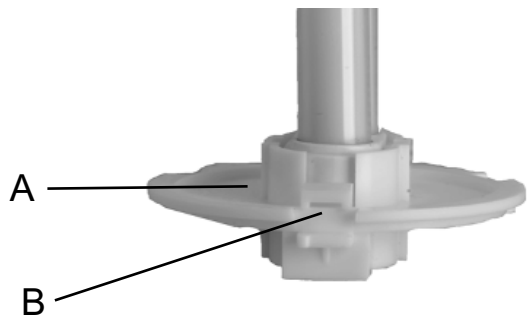
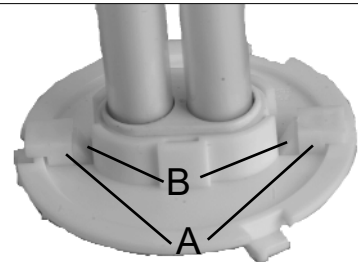

fig 3



Declaration of Conformity

We, the sole importer into the UK, declare that the product listed here is in conformity with the following EEC standards and directives.

Fluorescent Lantern
Model ML109
89/336/EEC EMC Directive



The construction file for this product is held by the Manufacturer and may be inspected, by a national authority, upon request to Jack Sealey Ltd.

Signed by Mark Sweetman

3rd January 2002

For Jack Sealey Ltd. Sole importer into the UK of Sealey Power Products.

NOTE: It is our policy to continually improve products and as such we reserve the right to alter data, specifications and component parts without prior notice.

IMPORTANT: No liability is accepted for incorrect use of this equipment.

WARRANTY: Guarantee is 12 months from purchase date, proof of which will be required for any claim.

INFORMATION: For a copy of our latest catalogue and promotions call us on 01284 757525 and leave your full name and address, including postcode.