

Thank you for purchasing a Sealey product. Manufactured to a high standard this product will, if used according to these instructions and properly maintained, give you years of trouble free performance.

⚠ IMPORTANT: PLEASE READ THESE INSTRUCTIONS CAREFULLY. NOTE THE SAFE OPERATIONAL REQUIREMENTS, WARNINGS & CAUTIONS. USE THE PRODUCT CORRECTLY AND WITH CARE FOR THE PURPOSE FOR WHICH IT IS INTENDED. FAILURE TO DO SO MAY CAUSE DAMAGE AND/OR PERSONAL INJURY AND WILL INVALIDATE THE WARRANTY. PLEASE KEEP INSTRUCTIONS SAFE FOR FUTURE USE.

1. SAFETY INSTRUCTIONS

DANGER! If using the lamp with the vehicle engine running ensure that there is adequate ventilation. **Breathing exhaust fumes can be fatal.**

- ❑ **WARNING!** DO NOT look directly into the light.
- ✓ Ensure the ML100 is unplugged from cigarette lighter socket when you have finished using it and before cleaning or maintaining the light.
- ✓ Keep the lens clean. DO NOT use abrasives, and do not touch the lens whilst in use as it will be hot.
- ✓ Ensure the surface you choose to stand the light on is sound and stable. Ensure that the tripod is fully opened.
- ✗ DO NOT allow the light to get wet, or use in wet locations.
- ✗ DO NOT place the lamp face down on a surface while it is in use.
- ✗ DO NOT use the light if it or the cigarette lighter plug or wire is damaged.
- ✓ When you have finished using the unit unplug it from the cigarette lighter and store in a safe, dry, childproof location.

2. DESCRIPTION

The ML100 consists of composite casing with folding tripod and ground spike. The angle adjustable head is fitted with a power switch and has 5 metres of cable with a cigarette lighter plug.

Reflector Ø168 mm
Overall Height (with grip + tripod) 500 mm

Output 1.5 million candle power
Bulb H1 12V 100W

3. ASSEMBLY AND USE

3.1. ASSEMBLY

3.1.1. Grip

3.1.1.1. With grip assembled as supplied, slide shoe (fig. 1.A) onto the foot of the lamp unit (fig. 3. 1) from the front towards the back. Ensure that the latch (fig. 3.2) is up before sliding the shoe on and then push the latch down to lock the shoe in place.

3.1.2. Grip with tripod

3.1.2.1. Fit grip as above and then unscrew lower collar (fig. 1. E). Remove tripod (fig. 1.D) from inside grip (fig. 1.C), reverse it and pass the tripod legs through collar E as shown in fig. 2.

3.1.2.2. Screw collar E back onto grip C and open tripod legs.

3.1.3. Grip and ground spike

3.1.3.1. Fit the ground spike to the grip C with collar E as for the tripod. Note that the tripod must be removed from inside the grip before the spike can be fitted.

3.1.4. Tripod without grip

3.1.4.1. Unscrew collar B from the shoe A.

3.1.4.2. Attach the tripod to the shoe using collar E (as in 3.1.2.)

3.2. USE

3.2.1.1. Plug the light into vehicle cigarette lighter socket (12 volt only) and switch on.

For prolonged use, keep the vehicle engine running to prevent battery discharge, **but see Section 1 Safety Instructions.**

Note: May be connected directly to a battery using optional adaptor, Sealey ref: ML/BCA.

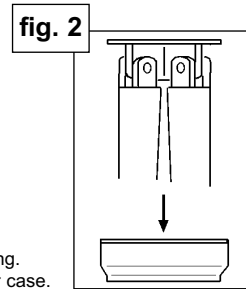
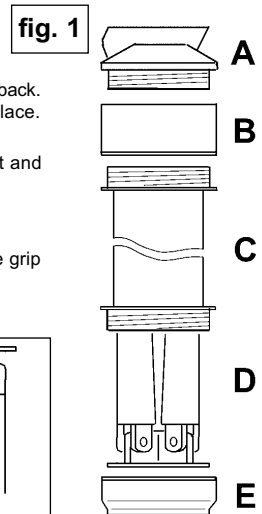

4. BULB REPLACEMENT

- 4.1. Turn off the lamp and disconnect from lighter socket. Allow the lamp to cool before proceeding.
- 4.2. Place lamp face down on a flat surface and remove the four screws (fig. 5) from the reflector case.
- 4.3. Lift the reflector case from the bezel and remove the white wire from the bulb terminal and the black wire from the bulb mounting plate.
- 4.4. Unclip and remove bulb retaining spring and lift bulb out, see fig. 4. Fit new bulb and refit retaining spring.
- 4.5. Reconnect black and white wires, fit reflector case over the bezel and retain with the four screws.

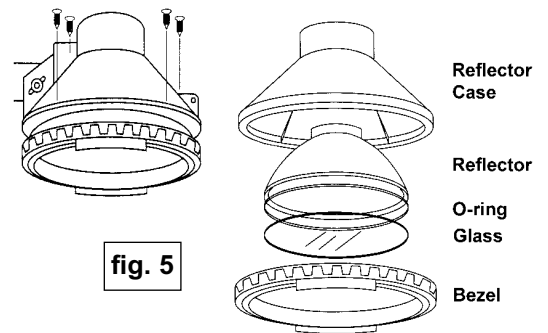
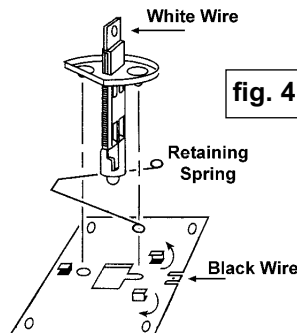
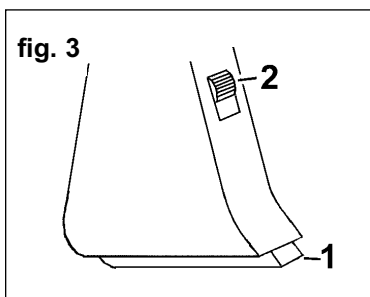

NOTE: It is our policy to continually improve products and as such we reserve the right to alter data, specifications and component parts without prior notice.

IMPORTANT: No liability is accepted for incorrect use of this equipment.

WARRANTY: Guarantee is 12 months from purchase date, proof of which will be required for any claim.

INFORMATION: For a copy of our latest catalogue and promotions call us on 01284 757525 and leave your full name and address, including postcode.