



# 5 PANEL MOBILE STORAGE RACK

MODEL NO: MK76.V2

Thank you for purchasing a Sealey product. Manufactured to a high standard, this product will, if used according to these instructions, and properly maintained, give you years of trouble free performance.

**IMPORTANT:** PLEASE READ THESE INSTRUCTIONS CAREFULLY. NOTE THE SAFE OPERATIONAL REQUIREMENTS, WARNINGS & CAUTIONS. USE THE PRODUCT CORRECTLY AND WITH CARE FOR THE PURPOSE FOR WHICH IT IS INTENDED. FAILURE TO DO SO MAY CAUSE DAMAGE AND/OR PERSONAL INJURY AND WILL INVALIDATE THE WARRANTY. KEEP THESE INSTRUCTIONS SAFE FOR FUTURE USE.



Refer to instructions



Wear protective gloves



Wear protective footwear

## 1. SAFETY

- ✓ Only use on firm, level, unobstructed surfaces which are capable of supporting the stand and body panels.
- ✗ **DO NOT** overload.
- ✓ Always load evenly with the centre of gravity of the load as near the centre as possible.
- ✓ Apply the brakes before commencing work.
- ✗ **DO NOT** stand/ride on the rack, or allow others to do so.
- ✓ Replace or repair damaged parts. Use only recommended parts. Unauthorised parts may be dangerous and will invalidate the warranty.
- ☐ **WARNING!** Failure to comply with these instructions may result in loss of load, damage to the rack or other property and/or personal injury.
- ☐ **WARNING!** The warnings, cautions and instructions discussed in this instruction manual cannot cover all possible conditions and situations that may occur. It must be understood that common sense and caution are factors which cannot be built into this product, but must be applied by the operator.

## 2. INTRODUCTION

Suitable for windscreens, sheet metals, bonnets and doors as well as other large items. Store up to five panels with a max. capacity of 150kg. Rack includes 12 foam-cushioned support arms to protect the items held within it. Fitted with four castors, two with brakes, for maximum manoeuvrability and safe positioning.

## 3. SPECIFICATION

Model No.....MK76  
 Width.....700mm  
 Height.....635mm  
 Arm Length.....630mm  
 Max. Capacity.....150kg

## 4. ASSEMBLY

Assemble panel stand according to the diagram overleaf.



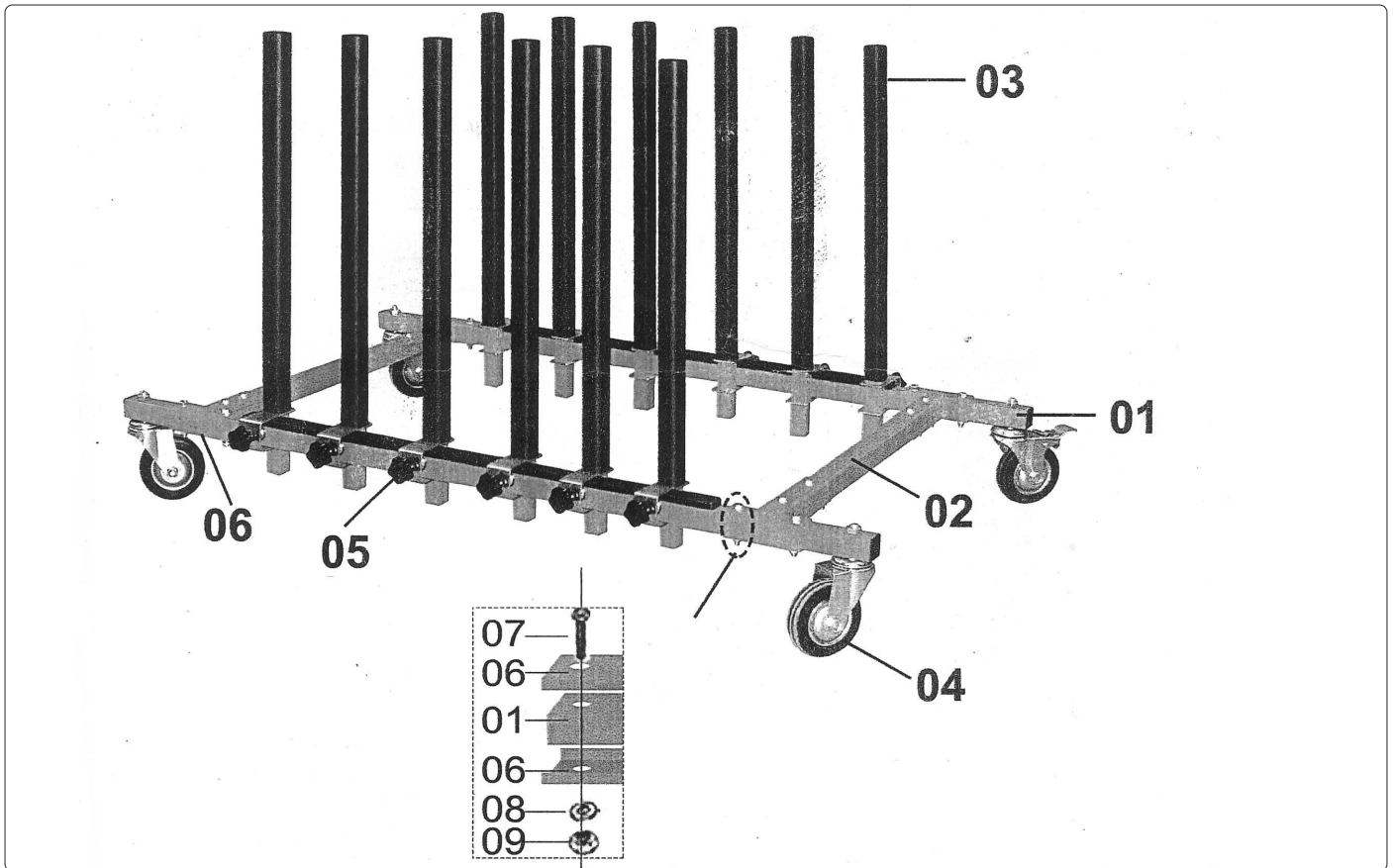

Number	Description	Quantity
1	Base tube (Long)	2
2	Base tube (Short)	2
3	Support arm	12
4	4" PP Castor	4
5	Handle with buckle	12
6	T Bracket clamp	8
7	Bolt M8 x50mm	16
8	Washer M8	16
9	Nut M8	16



**ENVIRONMENT PROTECTION**

Recycle unwanted materials instead of disposing of them as waste. All tools, accessories and packaging should be sorted, taken to a recycling centre and disposed of in a manner which is compatible with the environment. When the product becomes completely unserviceable and requires disposal, drain any fluids (if applicable) into approved containers and dispose of the product and fluids according to local regulations.



**Note:** It is our policy to continually improve products and as such we reserve the right to alter data, specifications and component parts without prior notice. Please note that other versions of this product are available. If you require documentation for alternative versions, please email or call our technical team on [technical@sealey.co.uk](mailto:technical@sealey.co.uk) or 01284 757505.

**Important:** No Liability is accepted for incorrect use of this product.

**Warranty:** Guarantee is 12 months from purchase date, proof of which is required for any claim.

Sealey Group, Kempson Way, Suffolk Business Park, Bury St Edmunds, Suffolk. IP32 7AR

01284 757500

[sales@sealey.co.uk](mailto:sales@sealey.co.uk)

[www.sealey.co.uk](http://www.sealey.co.uk)