

Thank you for purchasing a Sealey product. Manufactured to a high standard this product will, if used according to these instructions and properly maintained, give you years of trouble free performance.



**IMPORTANT: PLEASE READ THESE INSTRUCTIONS CAREFULLY. NOTE THE SAFE OPERATIONAL REQUIREMENTS, WARNINGS & CAUTIONS. USE THE PRODUCT CORRECTLY AND WITH CARE FOR THE PURPOSE FOR WHICH IT IS INTENDED. FAILURE TO DO SO MAY CAUSE DAMAGE AND/OR PERSONAL INJURY AND WILL INVALIDATE THE WARRANTY. PLEASE KEEP INSTRUCTIONS SAFE FOR FUTURE USE.**

### 1. SAFETY INSTRUCTIONS

- ❑ **WARNING! Before use, ensure the motorcycle or quadbike to be lifted has a suitable structure and centre of gravity to accommodate the lift arms without damaging the bike. DO NOT use if the lift will foul on the exhaust or other vulnerable parts. Remove lower fairing or obstructing trims before use. Ensure the bike is adequately strapped onto the lift once required height is attained.**
- ✓ Maintain the lift in good condition (use an authorised service agent).
- ✓ Replace or repair damaged parts. *Use genuine parts only. Unauthorised parts may be dangerous and will invalidate the warranty.*
- ✓ Use a qualified person to lubricate and maintain the lift. **DO NOT** use brake fluid to top up hydraulic unit.
- ✓ Locate the lift in a suitable work area, keep area clean and tidy and free from unrelated materials, and ensure that there is adequate lighting. Also ensure the floor is level and strong enough (preferably concrete) to take the weight of the lift and the bike. **DO NOT** operate the lift on tarmac/dam, as the surface may be unstable.
- ✓ Keep the lift clean for best and safest performance.
- ✓ Before use, stabilise the lift by turning the locking bolts (Fig 3 A) so that the lift is raised off of its wheels.
- ✓ The maximum bike weight is 550kgs. **DO NOT** exceed this rated capacity.
- ✓ Remove ill fitting clothing. Remove ties, watches, rings and other loose jewellery, and contain long hair.
- ✓ Maintain correct balance and footing, do not over-reach. Ensure the floor is not slippery and wear non-slip shoes.
- ✓ Ensure the bike is adequately secured to the lift with appropriate straps after having been raised to the required height.
- ✓ Before lifting check that there are no overhead obstructions.
- ✓ When lift has been raised to the working height ensure that the safety arms are engaged to prevent accidental lowering.
- ✓ Keep children and unauthorised persons away from the work area.
- ✓ The lowering speed will vary according to the weight of the load and the amount by which the release pedal is depressed.
- ✗ **DO NOT** use the lift for a task it is not designed to perform.
- ✗ **DO NOT** operate the lift if damaged.
- ✗ **DO NOT** exceed the rated capacity of the lift.
- ✗ **DO NOT** operate the lift when you are tired or under the influence of alcohol, drugs or intoxicating medication.
- ✗ **DO NOT** allow untrained persons to operate the lift.
- ✗ **DO NOT** attempt to transport a load on the lift. The lift must only be used in a static position for raising and lowering loads.
- ✗ **DO NOT** make any modifications to the lift and **DO NOT** adjust or tamper with safety valve.
- ✓ Before lowering the lift ensure that there are no obstructions underneath and that all persons are standing clear of the lift.
- ✓ Before storing in a safe area, ensure all parts are clean and free of grease and oil. Store lift in the lowest position.

### 2. INTRODUCTION

The MC480.V2 Motorcycle and Quadbike Lift is raised by a foot pedal and lowering is controlled by a foot pedal operated release valve.

Capacity: . . . . . 550kg  
Minimum height: . . . . . 130mm  
Maximum height: . . . . . 435mm

### 3. ASSEMBLY

Unpack the lift and check contents. Should there be any damaged or missing parts contact your supplier immediately.

#### 3.1. Assembly (fig.1)

- 3.1.1. Place hydraulic ram (I) into the base (A) using 2 M8 x 25 hex bolts (S), 2 spring washers (Q), 2 washers (T) and using bolt M6 x 15 (U) to fix ram to connecting rod (E). Tighten.
- 3.1.2. Fit foot pedal (J) to the hydraulic ram (I) and secure using M8 x 25 bolt (S).
- 3.1.3. Fit safety lock operation rod (D) into safety lock (N) using 2 spring washers (Q) and 2 nuts (R).
- 3.1.4. Fit manoeuvring handle (F) to connecting rod (E) using a bolt M8 x 25 (S).

#### 3.2. Before first use

- 3.2.1. Before using the lift, purge the hydraulic circuit in order to eliminate any air in the system, by depressing the release pedal and at the same time pump the lift pedal 15 to 20 times.
- 3.2.2. Now test the lift by raising it to its full height and then lowering it. Press the release valve pedal gently to slowly lower the lift.

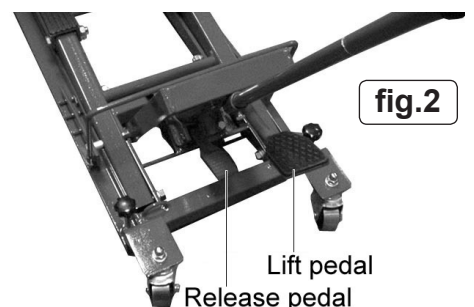
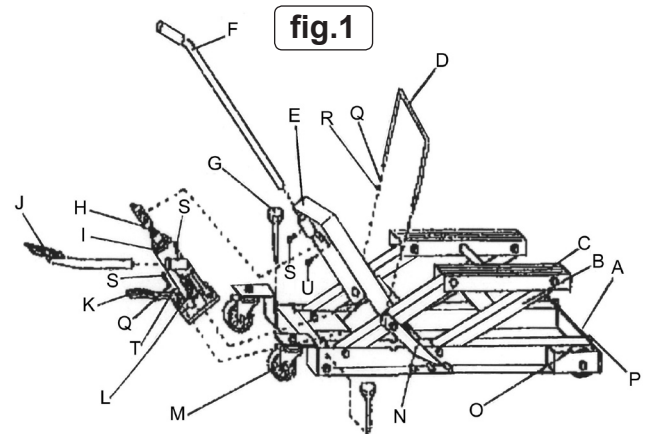

## 4. OPERATING INSTRUCTIONS

- ❑ **WARNING! Ensure you read, understand and apply the safety instructions before use.**
  - ❑ **WARNING! Before use, ensure the motorcycle or quadbike to be lifted has a suitable structure and centre of gravity to accommodate the lift arms without damaging the bike.**  
**DO NOT use if the lift will foul on the exhaust or other vulnerable parts. Remove any lower fairing. Ensure the bike is adequately strapped onto the lift when required height is attained.**
- 4.1. Position the bike in a suitable area, checking that the surface on which the lift will stand is solid and flat (preferably concrete). Ensure there is good access and clearance beneath the bike for the lift to be wheeled under.
  - 4.2. Wheel lift under bike so that the centre of gravity of the bike is over the lifting arms, which must fit snugly against the underside of the bike.
  - 4.3. Screw the two locking bolts down to stabilise the lift by raising the wheels from the floor (fig.3A).
  - 4.4. Engage the safety lock so that the arms rest against the locking teeth.  
As the lift is raised the safety arms will draw back and engage with the locking teeth so that the stand cannot be inadvertently lowered (fig.4).
  - 4.5. Pump the foot pedal to raise the lift to the required height. Check that the locking arms (fig.4) are in place and proceed with the work.
  - 4.6. Secure the bike to the lift with suitable straps, ensuring that the bike will not move whilst work is in progress.
  - 4.7. When work is complete, check under the lift to ensure that there are no obstructions and that it is safe to lower the unit.  
Pump the lift a little higher to release the locking arms (fig.4). Lift the arms up and back so that they will not hinder the descent. Engage the release valve pedal with a firm and steady pressure to **GENTLY** lower lift, too small an amount of pressure on the release valve may make the lift lower more rapidly.  
**IMPORTANT:** Speed of descent is controlled by the release valve pedal (see above). Ensure that the descent is slow and controlled to avoid the risk of sudden dropping.
  - 4.8. When the lift is fully lowered, ensure the bike is standing on its wheels and is supported in the upright position. Unstrap the bike from the lift, raise the locking bolts (fig.3A) and move the lift from under the bike.

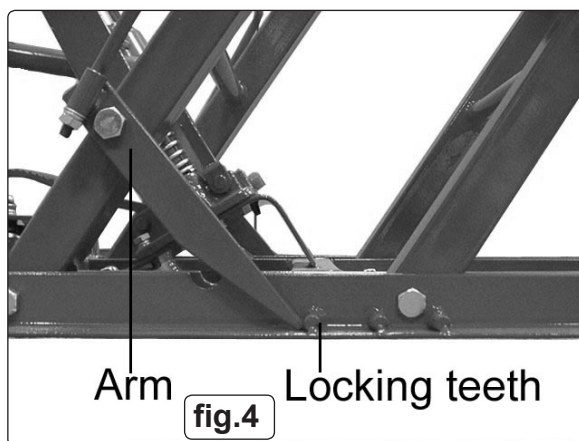
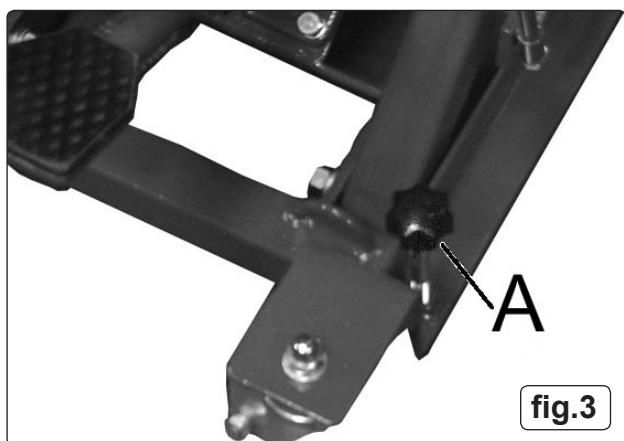

## 5. MAINTENANCE

- 5.1. When the lift is not in use, it must be in the lowest position to minimise ram and piston corrosion.
  - 5.2. Keep the lift clean and wipe off any oil or grease. Lubricate all moving parts with acid free oil.
  - 5.3. Before each use check all parts. If any part of the lift is damaged or defective remove lift from service and take necessary action to remedy the problem.  
**DO NOT** use the lift if it is believed to have been subjected to abnormal load or shock. Inspect and take appropriate action.
  - 5.4. Periodically check the pump piston and piston rod for signs of corrosion. Clean exposed areas with a clean oiled cloth.  
**IMPORTANT: Only fully qualified personnel should attempt maintenance or repair. Contact your authorised dealer.**
- ❑ **WARNING! Only a good quality hydraulic oil, such as SEALEY HYDRAULIC OIL must be used, DO NOT use brake fluid.**

### **IMPORTANT: NO RESPONSIBILITY IS ACCEPTED FOR INCORRECT USE OF THIS PRODUCT.**

Hydraulic products are only repaired by local service agents. We have service/repair agents in all parts of the UK.

**DO NOT RETURN THE PRODUCT TO US.** Please telephone us on 01284 757500 to obtain the address and phone number of your local agent. If product is under guarantee please contact your dealer.

### **De-commissioning product**

Should the product become completely unserviceable and require disposal, draw off the oil into an approved container and dispose of the product and the oil according to local regulations.

**NOTE:** It is our policy to continually improve products and as such we reserve the right to alter data, specifications and component parts without prior notice.

**IMPORTANT:** No liability is accepted for incorrect use of this product.

**WARRANTY:** Guarantee is 12 months from purchase date, proof of which will be required for any claim.

**INFORMATION:** For a copy of our latest catalogue and promotions call us on 01284 757525 and leave your full name and address, including postcode.



Sole UK Distributor, Sealey Group,  
Kempson Way, Suffolk Business Park,  
Bury St. Edmunds, Suffolk,  
IP32 7AR

☎ 01284 757500

🌐 www.sealey.co.uk

📠 01284 703534

✉ sales@sealey.co.uk