

Thank you for purchasing a Sealey product. Manufactured to a high standard this product will, if used according to these instructions and properly maintained, give you years of trouble free performance.

**IMPORTANT: PLEASE READ THESE INSTRUCTIONS CAREFULLY. NOTE THE SAFE OPERATIONAL REQUIREMENTS, WARNINGS AND CAUTIONS. USE THE PRODUCT CORRECTLY AND WITH CARE FOR THE PURPOSE FOR WHICH IT IS INTENDED. FAILURE TO DO SO MAY CAUSE DAMAGE AND/OR PERSONAL INJURY AND WILL INVALIDATE THE WARRANTY. PLEASE KEEP INSTRUCTIONS SAFE FOR FUTURE USE.**

### 1. SAFETY INSTRUCTIONS

- ❑ **WARNING! Ensure the bike is adequately secured to the lifting platform with appropriate straps before raising the load.**
- ✓ Maintain the lift in good condition (use an authorised service agent).
- ✓ Replace or repair damaged parts. *Use genuine parts only. Unauthorised parts may be dangerous and will invalidate the warranty.*
- ✓ Use a qualified person to lubricate and maintain the lift. **DO NOT** use brake fluid to top up hydraulic unit.
- ✓ Locate the lift in a suitable work area, keep area clean and tidy and free from unrelated materials, and ensure that there is adequate lighting. Also ensure that the floor is level and strong enough (preferably concrete) to take the weight of the lift and the bike. **DO NOT** operate the lift on tarmac, as the surface may be unstable.
- ✓ Keep the lift clean for best and safest performance.
- ✓ The maximum bike weight is 450kg. **DO NOT** exceed this rated capacity.
- ✓ Remove ill fitting clothing. Remove ties, watches, rings and other loose jewellery, and contain long hair.
- ✓ Maintain correct balance and footing, do not over reach. Ensure the floor is not slippery and wear non-slip shoes.
- ✓ Before lifting check that there are no overhead obstructions.
- ✓ When platform has been raised to the working height ensure the locking bar is engaged to prevent accidental lowering.
- ✓ Keep children and unauthorised persons away from the work area.
- ✓ The lowering speed will vary according to the weight of the load and the amount of pressure applied to the release pedal.
- x **DO NOT** attempt to ride a motorcycle up onto the lift
- x **DO NOT** use the lift for a task it is not designed to perform.
- x **DO NOT** operate the lift if damaged.
- x **DO NOT** exceed the rated capacity of the lift.
- x **DO NOT** operate the lift when you are tired or under the influence of alcohol, drugs or intoxicating medication.
- x **DO NOT** allow untrained persons to operate the lift.
- x **DO NOT** make any modifications to the lift and **DO NOT** adjust or tamper with the safety valve.
- x **DO NOT** sit or stand on the lift or hold onto it when it is being raised or lowered.
- x **DO NOT** attempt to raise the lift using manual strength.
- x **DO NOT** put any body parts within the interior frame of the lift whilst raising or lowering.
- x **DO NOT** use the ram alone to maintain a raised motorcycle. **ALWAYS** engage the locking mechanism.

- ✓ Before lowering the lift ensure that there are no obstructions underneath and that all persons are standing clear.
- ✓ Before storing in safe area, ensure all parts are clean and free of grease and oil. Store lift in the lowest position.

### 2. SPECIFICATION

Capacity .....	450kg
Overall Width/Length.....	800/3140mm
Height Minimum/Maximum.....	175/810mm
Net weight .....	72.5kg
Main Platform Width/length.....	145/2140mm

### 3. ASSEMBLY

The Lift comes completely assembled, except for the following items: (Refer to the drawing below).

- 3.1 **Tie Down Hooks:** The two front tie downs are longer than the rear pair. Slide the front tie downs (13) onto the rods either side of the front end of the platform and secure them with bolts (14) and nuts (15). Attach the shorter rear tie-downs (31) to the rear rods and secure with bolts (14) and nuts (15).
- 3.2 **Wheel Chock:** Place the wheel chock (17) on to the front end of the platform and align it with a suitable pair of holes. Slide the long bolt (19) through a hole in the side of the platform and through the sleeves welded to the back of the chock and out the other side of the platform. Secure with nut (18).
- 3.3 **Front Wheel Attachment.** Drop the ends of the 'U' shaped front wheel attachment (21) into the sleeves welded to the front end of the platform and secure with a pin (20) on either side.
- 3.4 **Support Leg and Wheel Assemblies:** Identify the two support leg/wheel assemblies (27) and (74). The front assembly (74) has a threaded hole between each pair of wheels. Insert the front assembly through the support arm tube at the lower, front end of the scissor frame. Rotate the assembly within the tube until the hole in the centre aligns with the hole in the tube. Secure with a bolt (26).
- 3.4.1 Now attach wheels (28), washers (29) and retaining rings (30) in the order shown in the diagram below. Identify the two lock bolts (41) with hand wheels attached and screw them into the holes between the wheels on either side.
- 3.4.2 Insert the rear assembly (27) through the support arm tube at the lower, back end of the scissor frame. Now attach wheels (28), washers (29) and retaining rings (30) in the order shown in the diagram below.

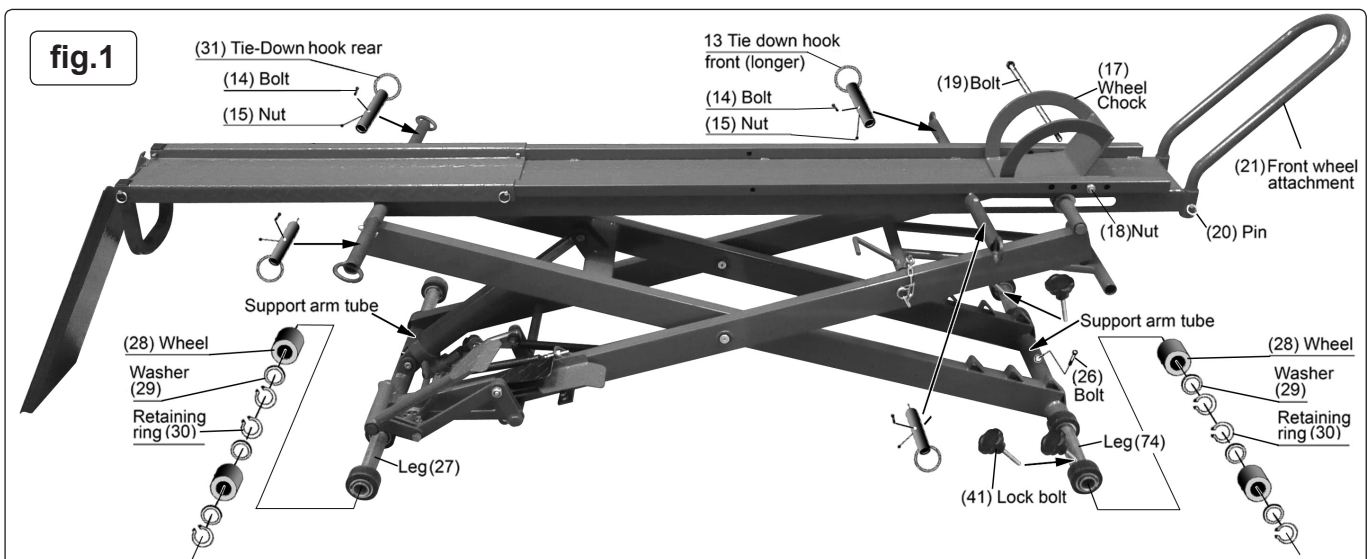

## 4. INTRODUCTION

All steel construction with foot operated, integral hydraulic pump and ram assembly. Fitted with platform safety lock device to prevent accidental lowering. Bike fixed by front wheel clamp, in addition, four eyelets allow tie downs to be used for added stability. Fitted with tyre width loading ramp. Base assembly fitted with transport wheels allowing lift to be moved in horizontal or vertical position. Can be stored in an upright position to save space when not in use.

## 5. OPERATING INSTRUCTIONS

- ❑ **WARNING!** Ensure that you read, understand and apply the safety instructions before use.
- ❑ **WARNING! DO NOT** attempt to overload the lift.
- 5.1 Position the lift in a suitable area, checking that the surface on which the lift will stand is solid and flat (preferably concrete).  
**Bleeding the system:** Whilst removing the oil filler plug from the ram the lift must have the safety locking bar engaged. Remove the locking bar pin shown in fig.6B. Using the main foot pedal (see fig.2A), raise the platform until the locking bar rides over the first locking bar stop (see fig.6). Press the slow descent pedal (see fig.2B) and allow the locking bar to settle fully against the stop.
- 5.2.1 Remove the oil filler cap from the side of the ram as shown in fig.2D.
- 5.2.2 Raise the lift slightly so that the locking bar is no longer under pressure. Using the locking bar lever (see fig.6C) raise the locking bar to the horizontal position and insert the locking bar pin. Press the slow descent foot pedal (see fig.2B) and allow the lift to settle to its lowest position so that the ram is fully retracted.
- 5.2.3 Fully open the release valve by depressing and holding down the fast descent pedal (see fig.2C). Now pump the main foot pedal 6 to 8 strokes. This will help release any pressurised air which may be trapped within the reservoir.
- 5.2.4 Raise the platform again, engage the safety locking bar and reinstall the oil filler plug.
- 5.2.5 Check to ensure that the pump operates smoothly before putting into service. Lubricate as instructed in the Maintenance Section.
- 5.2.6 Inspect before each use. Do not use if any components are bent, broken or cracked. components are noted.

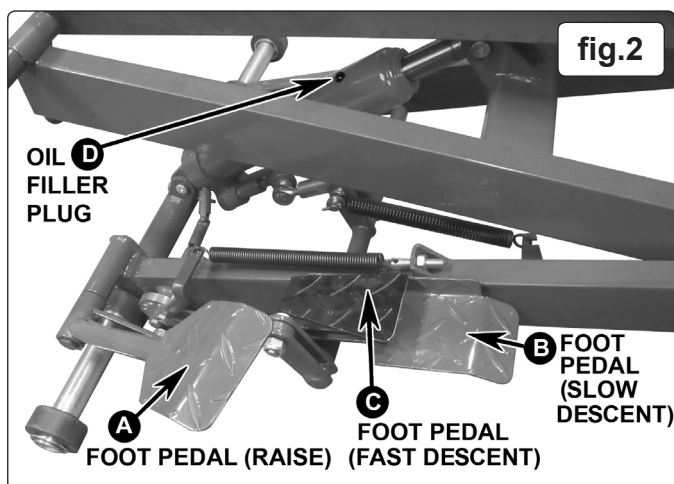

- 5.3 **Loading a motorcycle:** Lay the lift on a smooth flat surface such as concrete. Press and hold down the fast decent pedal to ensure that the ram is fully retracted and the lift is therefore in its lowest position.
- 5.3.1 Extend the rear section of the platform by removing the locking pins from the middle of the platform and pulling the extension out until the holes in the end of the extension piece are in line with a second set of holes for locking in the extended position. Insert the pins to lock the extension piece.
- 5.3.2 Hook the loading ramp into the two slots at the end of the extension piece and allow the free end to rest on the ground.
- 5.3.3 When the bike is fully on the ramp the front wheel will be retained between the front wheel attachment (C) and the

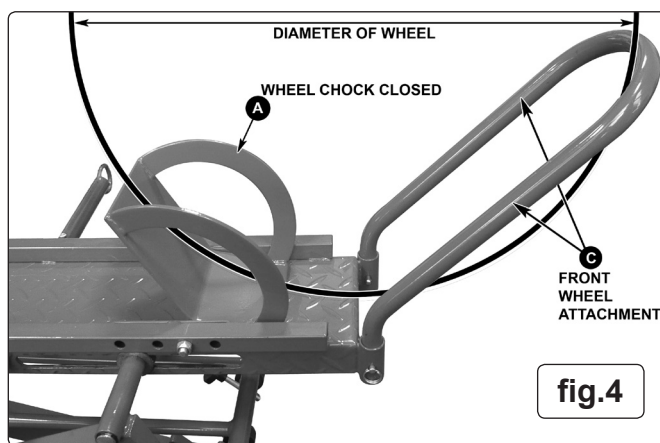
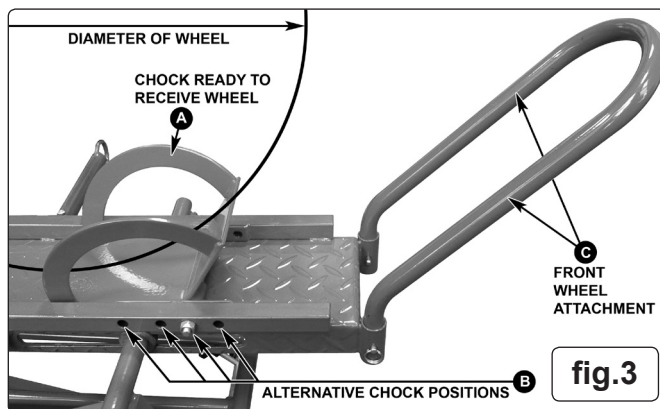

closed wheel chock (A) as shown in fig.4. The position of the wheel chock can be altered to cater for different diameter wheels by placing the pivot bolt in one of four positions as shown in fig.3. If the front wheel is not held firmly between the wheel chock and the front wheel attachment remove the motorcycle from the ramp and move the chock closer to the front wheel attachment.

- 5.3.4 The motorcycle must be loaded onto the centre of the loading ramp. Failure to do this could result in the motorcycle falling from the ramp resulting in serious injury to the operator and/or damage to the ramp or motorcycle.
- 5.3.5 Ensure the wheel chock is in the ready position to receive the motorcycle front wheel as shown in fig.3A.
- 5.3.6 Standing beside the motorcycle, push it up the ramp and all the way up onto the platform. As the front wheel on the motorcycle passes over the open wheel chock, the wheel chock will rotate forwards. The front tyre of the motorcycle will now be pushing down on the wheel chock, which will rotate it into the closed position. This causes the wheel chock to clasp the front wheel of your motorcycle in place, holding the motorcycle upright. This is NOT a substitute for securely tying the motorcycle onto the Lift using LOCKING RATCHET STYLE TIE DOWN STRAPS. Please ensure that the tie down straps are locked in place and hold the motorcycle safely on the Lift. Failure to correctly and safely tie the motorcycle in place will invalidate the warranty and may cause injury or death in the event that the motorcycle was to become dislodged from the lift.
- 5.4 **Correct Tie-down Procedure:**
- 5.4.1 Attach one end of the ratchet tie downs to the handlebars or fork area. Connect the other end of the straps to the forward outrigger tie-down rings. Ratchet the tie-down straps to compress the motorcycle suspension until the motorcycle is secure. This will typically require that you compress the front suspension on your motorcycle to approximately 75% of its full travel.
- 5.4.2 Secure the rear of the motorcycle in a similar manner using an attachment point such as the frame, swing arm, passenger foot rests e.t.c. Attach the other end of the straps to the rear outrigger tie-down rings, and ratchet until motorcycle is secure. Again, this will require you to compress the rear suspension on the motorcycle until there is no possibility that the motorcycle could become dislodged.

fig.5



**5.5 Raising the lift.**

**CAUTION: DO NOT** insert any body parts (e.g., fingers, arms, etc.) within the interior frame of the Lift while raising or lowering the Lift.

5.5.1 With the motorcycle tied down securely on the lift, ensure that the locking bar pin is removed (see fig.6B) so that the safety locking bar is free to move. See fig.7 below.

5.5.2 There are three preset heights for the lift depending on which stop the safety locking bar is engaged at (see fig.6). Pump the foot pedal until the safety locking bar rides over the chosen stop position and drops back onto the frame.

5.5.3 Now press the slow descent pedal (see fig.2B) to allow the lift to drop slightly so that the safety locking bar is firmly up against the chosen stop position.

**5.6 Lowering the lift.**

5.6.1 Pump the foot pedal to raise the lift slightly so that the safety locking bar is no longer pressing against the stop.

5.6.2 Raise the safety locking bar using lever 'C' in fig.6 and lock it in place with the locking bar pin. (See fig.6B)

5.6.3 Before lowering the lift ensure that there is nothing within the lift frame that could be damaged by the scissor action of the descending lift. *Ensure that no body parts such as hands, arms, legs or feet are within the interior frame of the lift.*

5.6.4 To lower the lift operate the slow descent pedal and allow the lift to settle to its lowest position in preparation for removing the motorcycle.

**5.7 Removing the motorcycle from the wheel chock.**

5.7.1 With the Tie-Down straps removed, push down on the handle bars of your motorcycle, slightly compressing the front suspension of the motorcycle.

5.7.2 Pull up and back on the motorcycle handlebars.

5.7.3 Keeping your hands on the handlebar brake, squeeze the motorcycle brake lever as the Wheel Chock rotates backwards. This freezes the front wheel of the motorcycle at the "balance point" between the closed position and the open position as the Wheel Chock is rotating backwards.

5.7.4 Pull the motorcycle backwards again, releasing the motorcycle handlebar brake lever. This will cause the Wheel Chock to rotate into the full open position and the front wheel of the motorcycle to fall onto the main lift platform.

5.7.5 Now you can roll the motorcycle off the Lift.

**5.8 Storing the lift vertically.**

5.8.1 The lift can be stored vertically as shown in fig.8 below.

**WARNING: In this position the lift is not free standing and must be fixed to a wall with a heavy duty cable or chain. Failure to adequately secure the lift could result in serious injury or death in the event of the lift falling over.**

5.8.2 With the lift in its lowest position remove the ramp from the end of the extended platform. Whilst the platform is still extended remove the pins from the 'U' shaped support on the end of the extension and rotate it through 180° so it is pointing vertically upwards. Use the two pins to lock it in this position. Remove the two pins from the other end of the extension and push the extension back onto the main platform until it lines up with another pair of holes in the rails. Insert the two pins through the rails to lock the extension piece in position.

5.8.3 **The lift must be raised by two people** from the wheel chock end of the platform. Continue to raise the lift allowing it to pivot on the wheels at the other end of the platform. As it reaches the vertical position the weight of the lift will shift from the wheels to the 'U' shaped support leaving the wheels slightly off the ground. Two people should continue to support the lift whilst it is manoeuvred up against the wall. Whilst one person continues to support the lift the other will secure it in position with a heavy cable or chains and a suitable lock.

**5.9 Putting the lift back down for use.**

5.9.1 When returning the lift to the horizontal position, equal care is required to avoid injury to persons. *At least two people should be on hand to support the lift as it is put down for service.* When finally lowering the lift to the ground take hold of the outer part of the cable tie down bars at the chock end of the lift to avoid fingers being trapped under the wheel bars.

fig.8

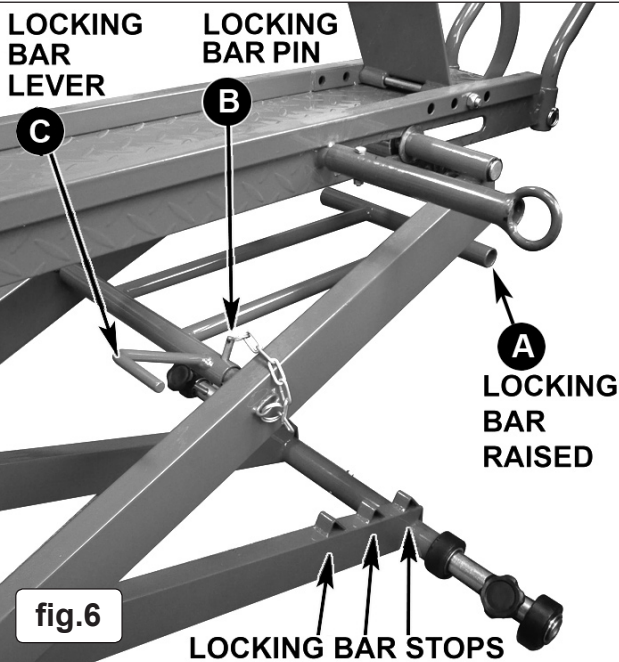
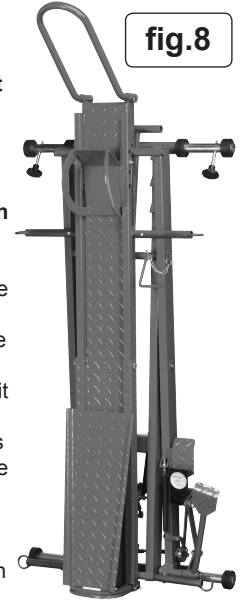

fig.6

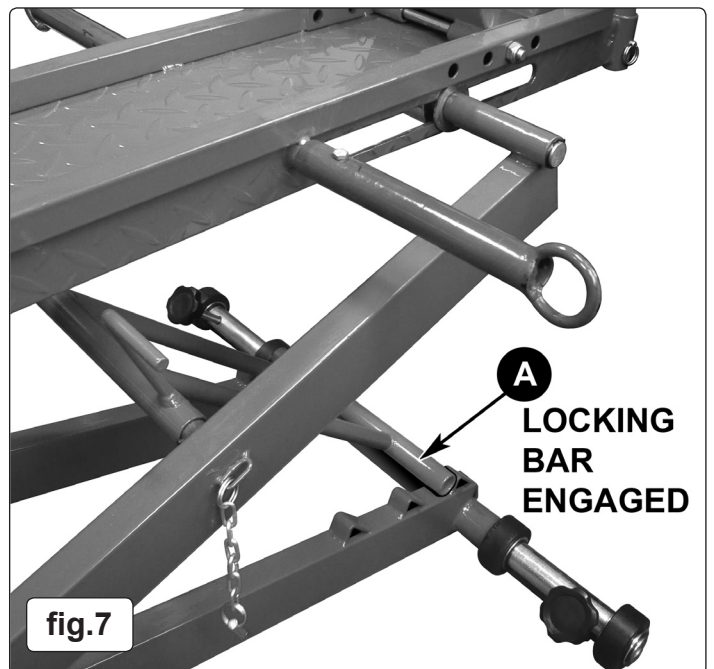
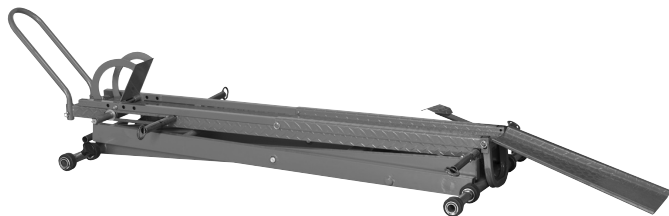

fig.7

## 6. MAINTENANCE

- 6.1. When the lift is not in use, it must be returned to its lowest position to minimise ram and piston corrosion.
- 6.2. Keep the lift clean and wipe off any oil or grease. Lubricate all moving parts..
- 6.3. Before each use check all parts. If any part of the lift is damaged or suspect, remove lift from service and take necessary action to repair.  
**DO NOT** use the lift if it is believed to have been subjected to abnormal load or shock. Inspect and take appropriate action.
- 6.4. Periodically check the ram and piston for signs of corrosion. Clean exposed areas with a clean oiled cloth.
- 6.5 **Topping up or changing the oil.**
- 6.5.1 To top up or change the oil the ram has to be removed from the lift.
- WARNING!** Only a good quality hydraulic oil, such as SEALEY HYDRAULIC OIL, must be used. DO NOT use brake fluid, transmission fluid or motor oil. Use of improper fluid can cause premature failure of the lift and the potential for sudden and immediate loss of load.
- IMPORTANT!:** Only fully qualified personnel should attempt maintenance or repair. Contact your authorised dealer.
- 6.5.2 Set the lift in the upright position and secure it against falling, ensuring that you have access to the ram on the underside of the lift.
- 6.5.3 Disconnect the two linkages attached to the ram. Remove the circlips from pivot pins at either end of the ram. Remove upper pivot pin. Support ram, remove lower pivot pin and remove ram.
- 6.5.4 With the ram in the upright position remove the filler plug and top up to the level of the filler hole. Replace the plug.
- 6.5.5 To change the oil lay the ram on its side and drain the oil into a suitable container.
- 6.5.6 Set the ram in the upright position and refill to the level; of the filler hole. Replace the plug.
- 6.5.7 Install the ram back into the lift by reversing the steps in section 6.5.3.



## 7. TROUBLESHOOTING

SYMPTOM	POSSIBLE CAUSE	SOLUTION
Jack will not lift load.	Release valve not tightly closed.	Close release valve fully.
	Overload condition.	Remove/reduce load
	Hydraulic unit malfunction	Service hydraulic unit
Jack will lift but not retain pressure	Release valve not tightly closed.	Close release valve fully.
	Overload condition.	Remove/reduce load
	Hydraulic unit malfunction	Service hydraulic unit
Jack will lift not lower after unloading	Reservoir overfilled	Drain fluid to correct level
	Linkages binding	Clean & lubricate moving parts
Poor lift performance	Fluid level low	Ensure proper fluid level
	Air trapped in system	Bleed system
Poor lift performance	Fluid level low	Top up to correct level
	Air trapped in system	Bleed system
Will not lift to full extension	Fluid level low	Ensure proper fluid level



### IMPORTANT: NO RESPONSIBILITY IS ACCEPTED FOR INCORRECT USE OF THE LIFT.

Hydraulic products are repaired by local service agents only. We have service/repair agents in all parts of the UK.

**DO NOT** return the product to us. Please call us on 01284 757500 to obtain the address and telephone number of your local agent.

If the product is under guarantee please contact your dealer.

**De-commissioning:** Should the lift become completely unserviceable, draw off the oil into an approved container and dispose of the lift and the oil according to local regulations.

**NOTE:** It is our policy to continually improve products and as such we reserve the right to alter data, specifications and component parts without prior notice.

**IMPORTANT:** No liability is accepted for incorrect use of this product.

**WARRANTY:** Guarantee is 12 months from purchase date, proof of which will be required for any claim.

**INFORMATION:** For a copy of our latest catalogue and promotions call us on 01284 757525 and leave your full name and address, including postcode.



Sole UK Distributor, Sealey Group,  
Kempson Way, Suffolk Business Park,  
Bury St. Edmunds, Suffolk,  
IP32 7AR



01284 757500



www.sealey.co.uk



01284 703534



sales@sealey.co.uk