

Thank you for purchasing a Sealey product. Manufactured to a high standard this product will, if used according to these instructions and properly maintained, give you years of trouble free performance.

**IMPORTANT: PLEASE READ THESE INSTRUCTIONS CAREFULLY. NOTE THE SAFE OPERATIONAL REQUIREMENTS, WARNINGS & CAUTIONS. USE THE PRODUCT CORRECTLY AND WITH CARE FOR THE PURPOSE FOR WHICH IT IS INTENDED. FAILURE TO DO SO MAY CAUSE DAMAGE AND/OR PERSONAL INJURY AND WILL INVALIDATE THE WARRANTY. PLEASE KEEP INSTRUCTIONS SAFE FOR FUTURE USE.**

## 1. SAFETY INSTRUCTIONS

- ❑ **WARNING! Before use, ensure the motorcycle or quadbike to be lifted has a suitable structure and centre of gravity to accommodate the lift arms without damaging the bike. DO NOT use if the lift will foul on the exhaust or other vulnerable parts. Remove lower fairing or obstructing trims before use and ensure the bike is adequately strapped onto the lift before operating.**
- ✓ Maintain the lift in good condition (use an authorised service agent).
- ✓ Replace or repair damaged parts. *Use genuine parts only. Unauthorised parts may be dangerous and will invalidate the warranty.*
- ✓ Use a qualified person to lubricate and maintain the lift. **DO NOT** use brake fluid to top up hydraulic unit.
- ✓ Locate the lift in a suitable work area, keep area clean and tidy and free from unrelated materials, and ensure that there is adequate lighting. Also ensure that the floor is level and strong enough (preferably concrete) to take the weight of the lift and the bike. **DO NOT** operate the lift on tarmac/adam, as the surface may be unstable.
- ✓ Keep the lift clean for best and safest performance.
- ✓ Before use, stabilise the lift by turning the levelling screws so that the lift is just raised off of its wheels.
- ✓ The maximum bike weight is 680kg. **DO NOT** exceed this rated capacity.
- ✓ Remove ill fitting clothing. Remove ties, watches, rings and other loose jewellery, and contain long hair.
- ✓ Maintain correct balance and footing, do not over reach. Ensure the floor is not slippery and wear non-slip shoes.
- ✓ Ensure the bike is adequately secured to the lifting platform with appropriate straps.
- ✓ Before lifting check that there are no overhead obstructions.
- ✓ When platform has been raised to the working height ensure the platform safety arms are engaged to prevent accidental lowering.
- ✓ Keep children and unauthorised persons away from the work area.
- ✓ The lowering speed will vary according to the weight of the load and the release valve setting.
- x **DO NOT** use the lift for a task it is not designed to perform.
- x **DO NOT** operate the lift if damaged.
- x **DO NOT** exceed the rated capacity of the lift.
- x **DO NOT** operate the lift when you are tired or under the influence of alcohol, drugs or intoxicating medication.
- x **DO NOT** allow untrained persons to operate the lift.
- x **DO NOT** attempt to transport a load on the lift. The lift must only be used in a static position for raising and lowering loads.
- x **DO NOT** make any modifications to the lift and **DO NOT** adjust or tamper with the safety valve.
- ✓ Before lowering the lift ensure that there are no obstructions underneath the platform and that all persons are standing clear.
- ✓ Before storing in safe area, ensure all parts are clean and free of grease and oil. Store lift in the lowest position.

## 2. INTRODUCTION & SPECIFICATION

Heavy steel construction with bottle jack style power unit. Lifting arms suitable for lifting bikes, quads, all terrain vehicles, trikes and transmissions. Features mechanical safety lock to prevent inadvertent lowering and stabiliser feet for added lifting control. Mounted on two fixed wheels and two castors for manoeuvrability.

### Specification

Capacity . . . . . 680kg  
 Minimum height . . . . . 120mm  
 Maximum height . . . . . 420mm  
 Weight . . . . . 34kg

## 3. ASSEMBLY

Unpack the lift and check contents with list below. Should there be any damaged or missing parts contact your supplier immediately.

### Contents

- Main Unit (inc. hex screw x2 and pivot bolt x2)
- Hydraulic Ram (inc. pivot pin)
- Ram Support Bar
- Safety Bar
- Pedal
- Handle
- Spring
- Castors . . . . . x2
- Rigid wheel . . . . . x2
- Lock Nuts . . . . . x2
- Washer . . . . . x4
- Philips screw
- Hex screw
- Levelling screws



**WARNING!** Keep your hands away from moving parts.

### 3.1. Assembly

- 3.1.1. Fit the castor wheels (fig.1A) to the main chassis with nuts and washers. Fit the fixed wheels to the opposite end of the frame with bolts and lock nuts.
- 3.1.2. Remove the two hex screws from the ram mounting point on the main chassis. Attach the hydraulic ram (fig.1B, fig.2F) to the main chassis mounting point, secure with the two hex screws.
- 3.1.3. Remove nuts and pivot bolts from the main frame and connect ram support and safety bar to the main frame using washers between nut and safety bar (refer to fig.2A).
- 3.1.4. Remove the pivot pin from the ram assembly and connect the ram support to the lifting arm (fig.2B), fasten with a cotter pin.
- 3.1.5. Attach the hex screw provided (fig.2C) into the base of the ram assembly.
- 3.1.6. Attach one end of the return spring (fig.2D) to the hex screw (fig.2C) and the other end over the pivot pin (fig.2B).
- 3.1.7. Remove the Philips screw located in the foot pump (fig.2E), insert the tube end of the foot pump into the pump on the hydraulic ram assembly (fig.1B). Secure with the Philips screw (fig.2E).
- 3.1.8. Take the two levelling bolts and insert in base of the main chassis (fig.1C).
- 3.2.3. To Attach the handle remove the locking pin from the top of the ram support (fig.1G) and slide the handle into the handle casing and secure with the locking pin.

### 3.2. Before first use

- 3.2.1. Before using the lift purge the hydraulic circuit. To eliminate any air in the system, fully press the release valve pedal (fig.1D) while pumping the lift pedal (fig.1E) 15 to 20 times.
- 3.2.2. Test the lift, unladen, by raising it to full height and then lowering it. Depress release valve pedal (fig.1D) slowly to control the rate of descent.

fig.1

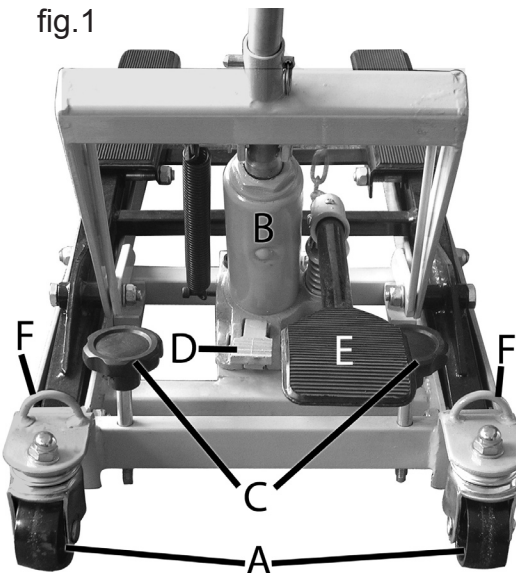

## 4. OPERATING INSTRUCTIONS

**WARNING!** Ensure you read, understand and apply the safety instructions before use.

**WARNING!** Before use, ensure the motorcycle to be lifted has a suitable structure and centre of gravity to accommodate the lift saddle without damaging the bike.

**DO NOT use if the lift will foul on the exhaust or other vulnerable parts. Remove any lower fairing and ensure the bike is adequately strapped to the lift before operating.**

- 4.1. Position the bike in a suitable area, checking that the surface on which the lift will stand is solid and flat (not tarmacadam). Ensure that there is good access and clearance beneath the bike for the lift to be wheeled under.
- 4.2. Position lift under bike so that the centre of gravity of the bike is over the saddle, which must fit snugly against the underside of bike.
- 4.3. By depressing the lift pedal (fig.1E), raise the saddle up to the underside of the bike.
- 4.2. Screw down the two levelling screws (fig.1C) to just lift the castors off the ground. This will ensure that the lift does not move during use.
- 4.5. Pump the lift pedal (fig.1E) to raise the load. **NOTE!** We recommend using an assistant to steady the bike.
- 4.6. When the lift is being raised the safety bar (fig.2G) will engage with the tabs on the frame so that the lift cannot be inadvertently lowered.
- 4.7. When the bike is at the desired height secure the bike to the saddle through the four anchors on the main frame (fig.1F) two being at the rear and two being at the front of the lift, under the saddle. Use the four ratchet tie downs with loop straps (**not supplied**) to prevent damage to body work. Hook one end of each tie down to the anchors on the base of the lift, then secure the other end onto a solid non moving part of the bike. **DO NOT** attempt to raise the bike while tie downs are secured.
- 4.8. When work is complete, check under the lift to ensure that there are no obstructions and that it is safe to lower the unit. Disengage the safety bar from the frame tabs, secure the bar with attached chain to prevent it from engaging whilst lowering and then **SLOWLY** press the release valve pedal (fig.1D) to **GENTLY** lower the lift.
- ▲ **IMPORTANT:** Speed of lowering is controlled by the release valve. The more the valve is opened the more rapidly the lift descends. Ensure the descent is slow and controlled.
- 4.9. When the lift is fully lowered, ensure the bike is on its wheels and supported in the upright position. Unstrap the bike from the lift, raise the levelling screws, and move the lift from under the bike.

fig.2

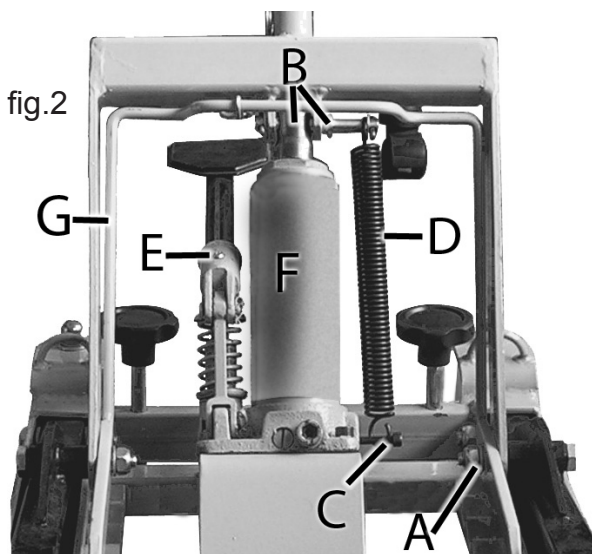

## 5. MAINTENANCE

- 5.1. When the lift is not in use, it must be stored in the lowest position to minimise ram and piston corrosion.
  - 5.2. Keep the lift clean and wipe off any oil or grease. Lubricate all moving parts with acid free oil.
  - 5.3. Before each use check all parts. If any part of the lift is damaged or suspect remove lift from service and take necessary action to repair. **DO NOT** use the lift if it is believed to have been subjected to abnormal load or shock. Inspect and take appropriate action.
  - 5.4. Periodically check the ram and piston for signs of corrosion. Clean exposed areas with a clean oiled cloth.
  - 5.5. The hydraulic oil level is checked as follows:
    - 1) Position the fully lowered lift on a level surface.
    - 2) Remove filler plug. Correct oil level is to filler hole - add hydraulic oil as necessary.
- WARNING! Only a good quality hydraulic oil, such as SEALEY HYDRAULIC OIL, must be used. DO NOT use brake fluid.**
- IMPORTANT: Only fully qualified personnel should attempt maintenance or repair. Contact your authorised dealer.**

**IMPORTANT: NO RESPONSIBILITY IS ACCEPTED FOR INCORRECT USE OF THE LIFT.**

*Hydraulic products are only repaired by local service agents. We have service/repair agents in all parts of the UK.*

**DO NOT RETURN THE PRODUCT TO US.** Please telephone us on 01284 757500 to obtain the address and phone number of your local agent. If product is under guarantee please contact your dealer.

**De-commissioning product**

Should the lift become completely unserviceable, draw off the oil into an approved container and dispose of the lift and the oil according to local regulations.

**NOTE:** It is our policy to continually improve products and as such we reserve the right to alter data, specifications and component parts without prior notice.

**IMPORTANT:** No liability is accepted for incorrect use of this product.

**WARRANTY:** Guarantee is 12 months from purchase date, proof of which will be required for any claim.

**INFORMATION:** For a copy of our latest catalogue and promotions call us on 01284 757525 and leave your full name and address, including postcode.



**Sole UK Distributor, Sealey Group,**  
Kempson Way, Suffolk Business Park,  
Bury St. Edmunds, Suffolk,  
IP32 7AR



01284 757500



01284 703534



www.sealey.co.uk



sales@sealey.co.uk