



**SPACE WARMER® PROPANE HEATER**  
**10,250-15,354BTU/HR TRIPOD MOUNTED**  
 MODEL NO: **LP14.V2**

Thank you for purchasing a Sealey product. Manufactured to a high standard, this product will, if used according to these instructions, and properly maintained, give you years of trouble free performance.

**IMPORTANT:** PLEASE READ THESE INSTRUCTIONS CAREFULLY. NOTE THE SAFE OPERATIONAL REQUIREMENTS, WARNINGS & CAUTIONS. USE THE PRODUCT CORRECTLY AND WITH CARE FOR THE PURPOSE FOR WHICH IT IS INTENDED. FAILURE TO DO SO MAY CAUSE DAMAGE AND/OR PERSONAL INJURY AND WILL INVALIDATE THE WARRANTY. KEEP THESE INSTRUCTIONS SAFE FOR FUTURE USE.



Refer to instruction manual



Hot surface

This product is only suitable for well insulated areas or occasional use.

**1. SAFETY**

**1.1. GENERAL SAFETY**

- ▲ **IMPORTANT:** The LP14.V2 is a mobile, propane-fired, unvented, infrared space heater for **commercial** applications only. It is designed for use with Propane cylinders of between 7kg to 15kg gas capacity. **DO NOT use domestically.**
- ☐ **WARNING! Use only in well ventilated spaces of more than 15m<sup>3</sup> to prevent an accumulation of dangerous combustion gases.**
- x **DO NOT** operate heater in basements or otherwise below ground level, in high rise flats, bathrooms or bedrooms.
- x **DO NOT** operate heater in leisure vehicles such as caravans and autocaravans.
- ☐ **WARNING! Heater will become very hot during use.**
- ☐ **WARNING! Ensure Health & Safety, local authority, and general workshop practice regulations are adhered to when using this equipment.**
- ✓ Familiarise yourself with the application and limitations of the heater, as well as the potential hazards.
- ☐ **WARNING! Disconnect the heater from the gas supply before performing any maintenance.**
- ✓ Maintain the heater in good condition (use an authorised service agent).
- ✓ Replace or repair damaged parts. *Use genuine parts only. Unauthorised parts may be dangerous and will invalidate the warranty.*
- ☐ **WARNING! Keep all guards and holding screws in place, tight and in good working order. The guard on this appliance is to prevent risk of fire or injury from burns and no part of it should be permanently removed. IT DOES NOT GIVE FULL PROTECTION FOR YOUNG CHILDREN OR THE INFIRM.** Check regularly for damaged parts. A guard or any other part that is damaged must be repaired or replaced before the heater is next used. Avoid twisting the regulator's flexible tube. The tube should be inspected for damage regularly and replaced if damage is found. Refer to the tube for its specification and length.
- ✓ Keep gas hose away from heat, oil and sharp edges. Ensure that all connections are secure.
- ✓ Keep the heater clean for best and safest performance.
- ✓ Ensure the propane bottle is in a stable upright position before igniting the heater. **DO NOT** use with the bottle in any position other than upright.
- x **DO NOT** use any fuel other than propane.
- ✓ Ensure there are no flammable or combustible materials within 2 metres of the heater and that nothing, including walls, is less than 500mm from any surface of the heater.
- x **DO NOT** use the heater where there are flammable liquids, solids or gases such as paint solvents, etc.
- ☐ **WARNING! NOT** to be used for the heating of habitable areas of domestic premises: for use in public buildings, refer to national regulations.
- ☐ **WARNING! DO NOT** use in basements or areas below ground level.
- x **DO NOT** move the heater when it is operating.
- x **DO NOT** use the heater for any purpose other than that for which it is designed.
- x **DO NOT** operate the heater if any parts are damaged or missing as this may cause failure and/or personal injury.
- x **DO NOT** adjust, or tamper with, the regulator.
- x **DO NOT** allow untrained persons to operate the heater.
- x **DO NOT** operate the heater when you are tired or under the influence of alcohol, drugs or intoxicating medication.
- ✓ When not in use disconnect from the gas supply and store in a safe, dry, childproof area.
- ✓ In the event of a gas leak immediately close the bottle valve, extinguish any flame and then place equipment in a well ventilated area, preferably outdoors, and away from any heat sources (including strong sunlight). Rectify cause of leakage.



fig.1

**2. INTRODUCTION**

Ceramic plaque type heater. Steel tube stand with built-in handle. Heat output from 10,250 to 15,354Btu/hr. Supplied with 37Mbar fixed regulator and 1.5mtr hose. Fully CE approved. Gas bottle not included.

**3. SPECIFICATION**

Model No. ....	LP14.V2
Fuel. ....	Propane
Output.....	10,250-15,354Btu/hr
Fuel Consumption. ....	0.220-0.330kg/hr

## 4. CONTENTS

### 4.1. Contents

4.1.1. Check content against the list below and, in the event of shortages or damage, contact your supplier.

Contents:

- Heater stand and mounting bolts
- Heater assembly
- Hose and gas bottle regulator

## 5. ASSEMBLY

5.1. Attach the stand to the heater assembly using the two bolts supplied. fig.2.

5.2. Fit the regulator to the gas bottle by screwing the POL nut anticlockwise into the port of the gas bottle valve. Tighten nut with spanner.

5.3. Attach one end of the gas hose to the barbed male connector on the regulator and hose clip. Attach the other end of the gas hose to the barbed male connector of the heater valve inlet and hose clip. A small amount of washing up liquid would assist fitting the hose. Ensure the hose is routed so that it does not touch any part of the heater, which will become hot during operation.

5.4. Open the gas bottle valve and, using soapy water, check all joints for leaks.

## 6. OPERATION

☐ **WARNING!** Ensure that you read, understand and apply the safety instructions in Section 1.

### 6.1. Siting the heater

✖ **DO NOT** use the heater where there are flammable liquids, solids or gases such as paint solvents, etc. Ensure there are no flammable or combustible materials within 2 metres of the heater and that nothing, including walls, is less than 500mm from any surface of the heater. Always ensure that the heater is facing away from the gas bottle.

### 6.2. Lighting heater (Refer to fig.3)

6.2.1. Open the gas bottle valve.

6.2.2. Push the heater control dial down and turn it clockwise to the full on position and keep it held down.

6.2.3. After a few seconds bring a flame up to the bottom edge of the burner.

6.2.4. After the gas ignites keep the dial held down for a further 20 seconds then turn the control dial anticlockwise to reduce the heat output to the required level.

### 6.3. Turning Heater Off

6.3.1. Close the gas bottle valve.

6.3.2. Changing propane bottle

6.3.3. Ensure the gas bottle valve is closed and then unscrew the POL nut and remove the regulator.

6.3.4. Fit regulator to new gas bottle. Check for gas leaks as in 5.4.

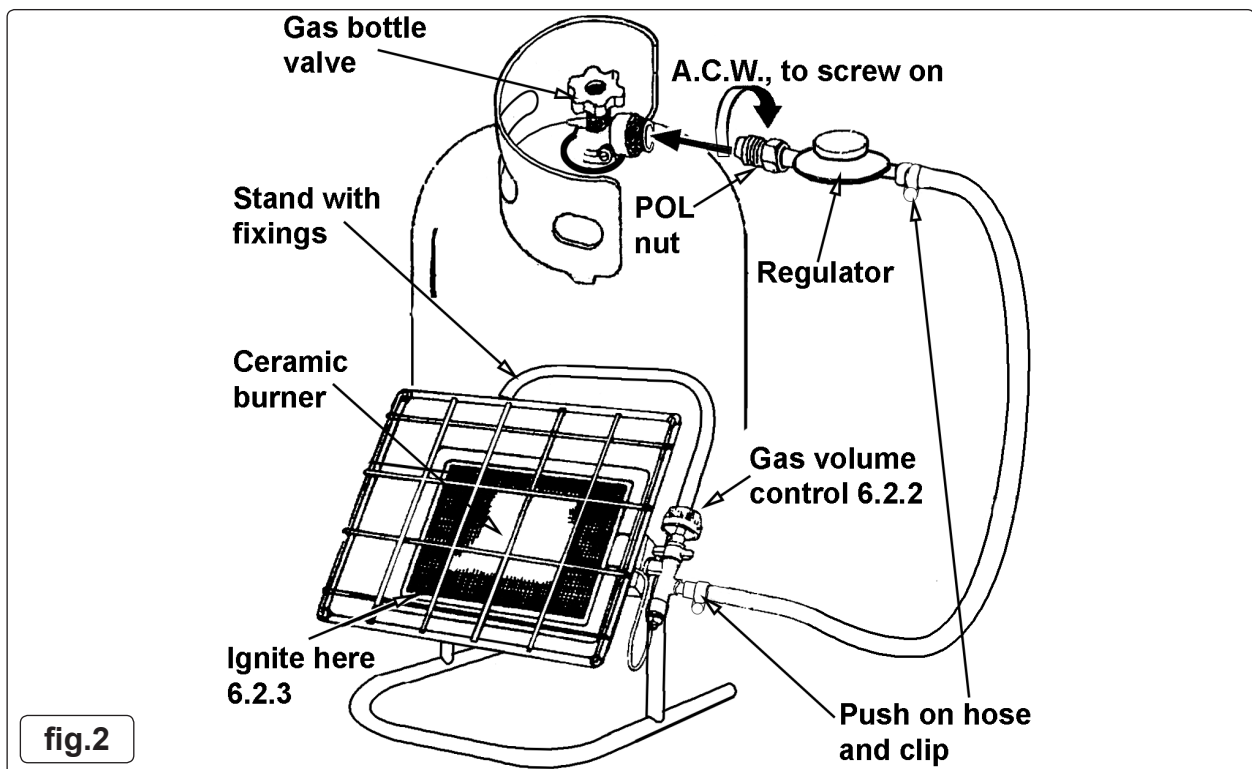

fig.2

## 7. MAINTENANCE

### 7.1. Storage

- 7.1.1. Disconnect the cylinder and store it in a well ventilated area away from combustable material, preferably in an outhouse.  
 7.1.2. The heater should be covered in a dry, dust free cover and placed in its original packaging.  
 7.1.3.

### 7.2. Cleaning

- \* **DO NOT** clean the heater when it has just been turned off.
- 7.2.1. Use a soft, dry cloth.  
 \* **DO NOT** clean with aggressive, abrasive or inflammable substances, they could cause a fire or damage the paint.  
 \*

### 7.3. Maintenance

- 7.3.1. Any repairs must be performed by specialised personnel and using original replacement parts.  
 7.3.2. To ensure proper operation of the burner, we recommend annual maintenance, performed at an authorised service centre.  
 \*
- DO NOT** make any modifications to the heater, it is dangerous!  
**NOTE:** Spiders or small insects could take up residence inside the burner or nozzle altering the flow of gas and combustion. Inspect them frequently.

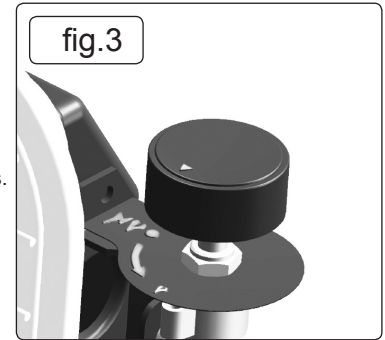

FAULT	POSSIBLE CAUSE	REMEDY
Gas leak	Regulator and hose connection. Valve and hose connection. Split or perished hose POL nut connection	Brush a solution of washing up liquid and water on to all connections and look for active bubbles. Tighten clips or replace hose. Check POL nut fitting is tight (ACW)
Inefficient combustion across the ceramic plaque.	Missing piece of ceramic fire clay.  Gas jet holes blocked.	Replace plaque or repair with PYRUMA (fire cement) and leave to set for approximately 48 hours. Clear blockages
Burner flame extinguishes during operation.	Low gas or empty bottle. Thermal element not hot enough.  The wind has extinguished the flame.  Thermal element faulty. Faulty manual valve.	Change the gas bottle. Go through the start up procedure again. Allow to cool before restarting. Move appliance away from draughts. Replace the thermocouple. Contact your Sealey Dealer. Replace the valve. Contact your Sealey Dealer.
Heater will not light.	Gas cylinder valve is closed  Volume control not opened fully when attempting ignition. Insects inside the burner	Turn on the gas cylinder control, check for leaks. Read instructions 6.2. ignition process.  Clear blockages.

### ENVIRONMENT PROTECTION



Recycle unwanted materials instead of disposing of them as waste. All tools, accessories and packaging should be sorted, taken to a recycling centre and disposed of in a manner which is compatible with the environment. When the product becomes completely unserviceable and requires disposal, drain any fluids (if applicable) into approved containers and dispose of the product and fluids according to local regulations.

**Note:** It is our policy to continually improve products and as such we reserve the right to alter data, specifications and component parts without prior notice.

**Important:** No Liability is accepted for incorrect use of this product.

**Warranty:** Guarantee is 12 months from purchase date, proof of which is required for any claim.

Sealey Group, Kempson Way, Suffolk Business Park, Bury St Edmunds, Suffolk. IP32 7AR



01284 757500



01284 703534



sales@sealey.co.uk



www.sealey.co.uk