



3W COB & 2W SMD LED RECHARGEABLE INSPECTION LIGHT WITH 180° MAGNETIC STAND

MODEL NO: **LED301**

Thank you for purchasing a Sealey product. Manufactured to a high standard, this product will, if used according to these instructions, and properly maintained, give you years of trouble free performance.



IMPORTANT: PLEASE READ THESE INSTRUCTIONS CAREFULLY. NOTE THE SAFE OPERATIONAL REQUIREMENTS, WARNINGS & CAUTIONS. USE THE PRODUCT CORRECTLY AND WITH CARE FOR THE PURPOSE FOR WHICH IT IS INTENDED. FAILURE TO DO SO MAY CAUSE DAMAGE AND/OR PERSONAL INJURY AND WILL INVALIDATE THE WARRANTY. KEEP THESE INSTRUCTIONS SAFE FOR FUTURE USE.

1. SAFETY

1.1. GENERAL

- × **DO NOT** shine directly into your, another person's or an animal's eyes.
- × **DO NOT** allow children to use the torch.
- × **DO NOT** use the torch if you suspect that the battery or the torch casing is damaged.
- × **DO NOT** attempt to repair/disassemble the light yourself.
- × **DO NOT** leave batteries in a discharged state. Before storage remove batteries.
- × **DO NOT** use/store the product in extreme temperatures.
- ✓ Protect this product from water, humidity or any liquids.

1.2. BATTERY SAFETY

- ☐ **WARNING!** To reduce the risk of burns or fire:
 - × **DO NOT** attempt to open the batteries.
 - × **DO NOT** crush, puncture, short contacts or dispose of in fire or water.
 - × **DO NOT** expose to temperatures above 60°C (140°F).
 - ✓ Replace only with the batteries designed for this product.
 - ✓ Recycle or dispose of used batteries as stipulated by local regulation.
 - ✓ If the electrolyte in the batteries gets on your skin, rinse thoroughly with water. If it gets in your eyes, rinse thoroughly with cool water and seek immediate medical attention.

2. INTRODUCTION

Lightweight light featuring a super bright 3W COB LED, which gives an even and constant spread of light, producing up to 200 lumens. 2W High power SMD LED torch producing up to 100 lumens. Integral hanging hook/belt clip and a magnetic base which can rotate through 180° for hands-free applications. Rechargeable 3.7V 1.2Ah lithium-ion battery for longer product life. Supplied with 300mm USB TYPE-C charging cable.

3. SPECIFICATION

MODEL NO:	LED301
Battery:	3.7V 1200mAh Li-Battery
Charging Time:	4hr
IP Rating:	IP20
LED Type:	3W COB + 2W SMD LED
Length:	165mm
Lumen Output:	100lm (SMD) 200lm (COB)
Operating Time:	2-4hr
Length:	165mm
Lumen Output:	100lm (SMD) 200lm (COB)
Operating Time:	3-4hr

4. OPERATION

4.1. CHARGING

4.1.1. Use the USB cable provided to charge the product.

4.2. Press ON/OFF:

- 4.2.1. Once to turn on the torch.
- 4.2.2. Twice to turn on the COB LED.
- 4.2.3. Three times to turn OFF.

5. MAINTENANCE

- ✓ Clean this product with a soft, slightly damp cloth.
- × **DO NOT** use any abrasive agents to clean the product.
- × **DO NOT** attempt to repair/disassemble the light yourself.

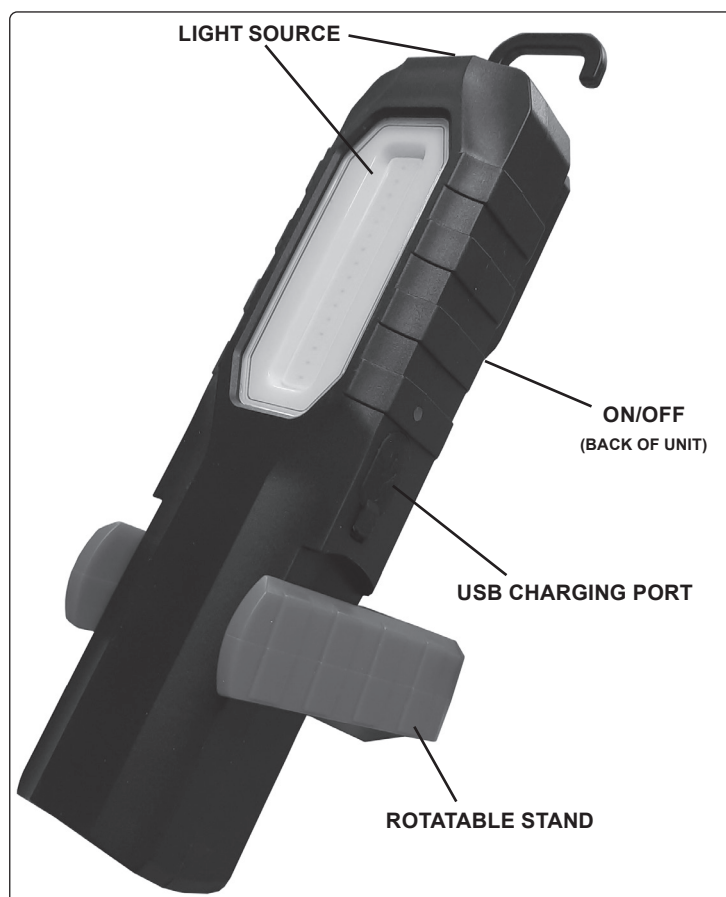



ENVIRONMENT PROTECTION

Recycle unwanted materials instead of disposing of them as waste. All tools, accessories and packaging should be sorted, taken to a recycling centre and disposed of in a manner which is compatible with the environment. When the product becomes completely unserviceable and requires disposal, drain any fluids (if applicable) into approved containers and dispose of the product and fluids according to local regulations.



REGISTER YOUR
PURCHASE HERE



WEEE REGULATIONS

Dispose of this product at the end of its working life in compliance with the EU Directive on Waste Electrical and Electronic Equipment (WEEE). When the product is no longer required, it must be disposed of in an environmentally protective way. Contact your local solid waste authority for recycling information.



Li-ion

BATTERY REMOVAL

Under the Waste Batteries and Accumulators Regulations 2009, Jack Sealey Ltd are required to inform potential purchasers of products containing batteries (as defined within these regulations), that they are registered with Valpak's registered compliance scheme. Jack Sealey Ltd Batteries Producer Registration Number (BPRN) is BPRN00705.

Note: It is our policy to continually improve products and as such we reserve the right to alter data, specifications and component parts without prior notice.

Important: No Liability is accepted for incorrect use of this product.

Warranty: Guarantee is 12 months from purchase date, proof of which is required for any claim.

Sealey Group, Kempson Way, Suffolk Business Park, Bury St Edmunds, Suffolk. IP32 7AR



01284 757500



sales@sealey.co.uk



www.sealey.co.uk