



EXTRA-SLIM SOLAR FLOODLIGHTS WITH WALL BRACKET SMD LED

MODEL NO: **LED16S.V3, LED20S.V2, LED30S.V2**

Thank you for purchasing a Sealey product. Manufactured to a high standard, this product will, if used according to these instructions, and properly maintained, give you years of trouble free performance.



IMPORTANT: PLEASE READ THESE INSTRUCTIONS CAREFULLY. NOTE THE SAFE OPERATIONAL REQUIREMENTS, WARNINGS & CAUTIONS. USE THE PRODUCT CORRECTLY AND WITH CARE FOR THE PURPOSE FOR WHICH IT IS INTENDED. FAILURE TO DO SO MAY CAUSE DAMAGE AND/OR PERSONAL INJURY AND WILL INVALIDATE THE WARRANTY. KEEP THESE INSTRUCTIONS SAFE FOR FUTURE USE.

1. SAFETY

- ✓ Maintain the light in good condition.
 - ✓ Ensure the light is installed correctly in accordance with these instructions.
 - ✓ Only install the light on a vertical surface.
 - ✗ **DO NOT** fix the light on any horizontal surface i.e. ceiling, or overhang.
 - ✓ Install away from flammable or combustible materials.
 - ✗ **DO NOT** direct the light into a persons eyes.
 - ✗ **DO NOT** install the light where it is likely to be knocked or hit.
 - ✗ **DO NOT** install in bathrooms, shower rooms, sauna or such locations.
 - ✗ **DO NOT** install near an exhaust outlet. e.g. boiler flue, dryer outlet or mirrored surfaces etc.
 - ✗ **DO NOT** put the light in an area that is well lit at night, e.g., near a street light. This may stop the sensor from determining when it is night time and will stop the light from operating.
 - ✓ The light must be securely fixed to the mounting surface. The screws and wall plugs supplied are suitable for masonry only.
 - ✓ Mount the light level and horizontal to the ground.
 - ✓ Turn the light off if it is not to be used for long periods.
 - ✓ Locate the light away from obstructions that block the light from reaching the solar panel such as overhanging tree branches, fences or buildings.
- Note:** If you have solar-powered LED lights, it's essential to charge them up completely before using them. Most solar lights need about 8 to 12 hours of direct sunlight for the initial charge.



2. INTRODUCTION

Extra slim floodlights with steel wall brackets. High quality Polycrystalline solar panels for improved longevity. Powerful SMD LED floodlights provide a wide spread of light, capable of lighting a large area. Features both daylight (CDS) and motion (PIR) sensors to switch on automatically. Includes two light modes: 5% brightness with 100% brightness when motion is detected and 100% brightness when motion is detected.

3. SPECIFICATION

Model No:	LED16S.V3	LED20S.V2	LED30S.V2
Battery:	3.7V 3Ah	3.7V 3Ah	2 x 3.7V 2.6Ah
IP Rating:	IP65	IP65	IP65
LED Type:	16W SMD	20W SMD	30W SMD
Lumen Output:	1600lm	2000lm	3000lm
Nett Weight:	0.275kg	0.38kg	0.71kg
PIR Motion Sensor:	Yes	Yes	Yes
Power:	16W	20W	30W

4. ASSEMBLY

- 4.1. Unpack the product and check contents. Should there be any damaged or missing parts contact your supplier immediately.
 - 4.2. **Give careful consideration to the position of solar-powered LED lights to ensure maximum direct sunlight. Ensure the unit is left in direct sunlight for a day before use.**
 - 4.3. With care remove the wall bracket from the light assembly by unscrewing the retaining thumb screws (fig 1).
 - 4.4. Locate the thumb screws, solar panel and light in a secure location.
 - 4.5. Place the wall bracket at your desired location and spot mark through the slots onto the fixing surface (fig 2).
 - 4.6. Secure wall bracket with appropriate fixings, wall plugs, to suit mounting surface.
 - 4.7. Reassemble the light assembly and use knobs to adjust angle (fig 3).
- ☐ **WARNING!** If working at height take adequate safety precautions to prevent injury from falling.

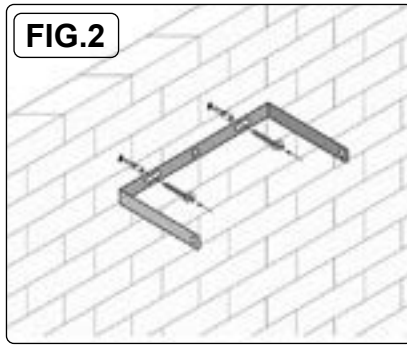
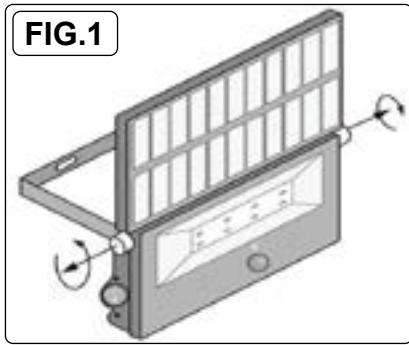

5. OPERATION

- 5.1. Adjust the solar panel upwards to maximise the amount of direct sunlight collected (fig 4).
- 5.2. Rotate the light downwards to obtain maximum coverage (figs 4 & 5).
- 5.3. Push the power button to switch on the light (fig 6).

❑ **WARNING!** To avoid unwanted activation ensure that the light is not positioned so it detects unwanted objects such as road traffic or people using nearby footpaths.

- 5.4. Green light illumination indicates that the floodlight is charging.

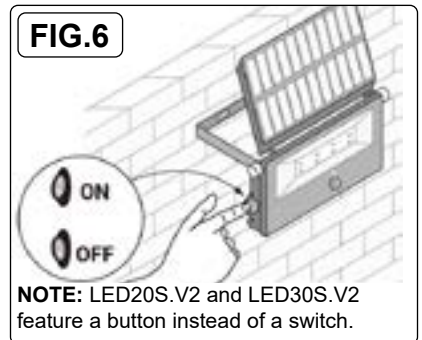
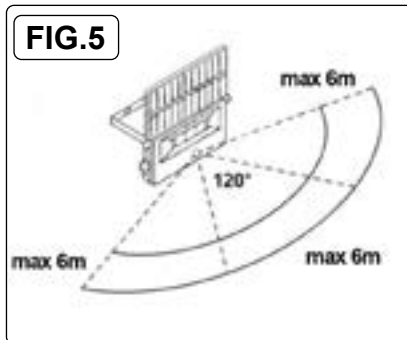
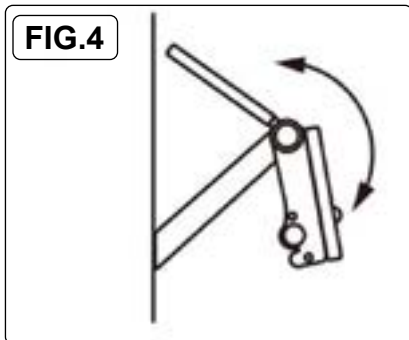

NOTE: LED20S.V2 and LED30S.V2 feature a button instead of a switch.

6. MAINTENANCE

- 6.1. Wipe clean with soft dry cloth.

✖ **DO NOT** use solvents.

NOTE: The light is a fully sealed unit with no serviceable parts on the LED16S.V3, however the LED20S.V2, LED30S.V2 (fig.7) have 18650 lithium batteries that are charged from the solar panel, simply unscrew the battery cap (anticlockwise) and replace when required. Battery orientation is marked on the rear of the lamp, adjacent to the battery access cap.



	<p>ENVIRONMENT PROTECTION</p> <p>Recycle unwanted materials instead of disposing of them as waste. All tools, accessories and packaging should be sorted, taken to a recycling centre and disposed of in a manner which is compatible with the environment. When the product becomes completely unserviceable and requires disposal, drain any fluids (if applicable) into approved containers and dispose of the product and fluids according to local regulations.</p>	<p>REGISTER YOUR PURCHASE HERE</p>
--	---	------------------------------------

	<p>WEEE REGULATIONS</p> <p>Dispose of this product at the end of its working life in compliance with the EU Directive on Waste Electrical and Electronic Equipment (WEEE). When the product is no longer required, it must be disposed of in an environmentally protective way. Contact your local solid waste authority for recycling information.</p>
--	--

	<p>BATTERY REMOVAL</p> <p>Under the Waste Batteries and Accumulators Regulations 2009, Jack Sealey Ltd are required to inform potential purchasers of products containing batteries (as defined within these regulations), that they are registered with Valpak's registered compliance scheme. Jack Sealey Ltd's Batteries Producer Registration Number (BPRN) is BPRN00705.</p>
--	--

Note: It is our policy to continually improve products and as such we reserve the right to alter data, specifications and component parts without prior notice.
Important: No Liability is accepted for incorrect use of this product.
Warranty: Guarantee is 12 months from purchase date, proof of which is required for any claim.