

INSTRUCTIONS FOR: 130 LED FLOODLIGHT WITH WALL BRACKET AND PIR SENSOR

MODEL No: **LED130S.V2**

Thank you for purchasing a Sealey product. Manufactured to a high standard this product will, if used according to these instructions and properly maintained, give you years of trouble free performance.



IMPORTANT: PLEASE READ THESE INSTRUCTIONS CAREFULLY. NOTE THE SAFE OPERATIONAL REQUIREMENTS, WARNINGS, AND CAUTIONS. USE THIS PRODUCT CORRECTLY, AND WITH CARE FOR THE PURPOSE FOR WHICH IT IS INTENDED. FAILURE TO DO SO MAY CAUSE DAMAGE, OR PERSONAL INJURY, AND WILL INVALIDATE THE WARRANTY.

1. SAFETY INSTRUCTIONS

1.1. ELECTRICAL.

- WARNING!** It is the user's responsibility to read, understand and comply with the following:
- WARNING!** THIS PRODUCT MUST BE INSTALLED BY A QUALIFIED ELECTRICIAN.
You must check all electrical equipment and appliances to ensure they are safe before using. You must inspect power supply leads, plugs and all electrical connections for wear and damage. You must ensure the risk of electric shock is minimised by the installation of appropriate safety devices. An RCCB (Residual Current Circuit Breaker) should be incorporated in the main distribution board. **You must** also read and understand the following instructions concerning electrical safety.
- 1.1.1. Ensure the light is connected to an appropriate electrical on/off switch.
- 1.1.2. Ensure the insulation on all cables and the product itself is safe before connecting to the mains power supply.
- 1.1.3. Ensure that cables are always protected against short circuit and overload.
- 1.1.4. Regularly inspect power supply, leads, plugs and all electrical connections for wear and damage, especially power connections, to ensure that none are loose.
- 1.1.5. **Important:** Ensure the voltage marked on the product is the same as the electrical power supply to be used.
- 1.1.6. **DO NOT** pull power cable once installed.
- 1.1.7. **DO NOT** pull power plugs from sockets by the power cable.
- 1.1.8. **DO NOT** use worn or damaged leads, plugs or connections. Immediately replace or have repaired by a qualified Electrician.

Ensure the unit is correctly earthed and wired according to the diagram figure 1 below.

- a) **Connect the GREEN/YELLOW earth wire to the earth terminal 'E'.**
 - b) **Connect the BROWN live wire to live terminal 'L'.**
 - c) **Connect the BLUE neutral wire to the neutral terminal 'N'.**
- After wiring, check there are no bare wires, that all wires have been correctly connected and that the wire restraint is tight.**

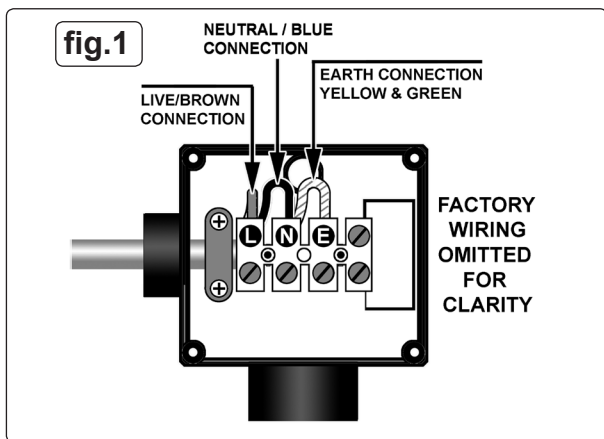

1.2. GENERAL SAFETY.

- WARNING!** Turn off the mains power supply before servicing or performing any maintenance.
- ✓ Maintain the light in good condition (Repairs must only be undertaken by a qualified electrician).
- ✓ Replace or repair damaged parts. Use genuine parts only, non authorised parts may be dangerous and will invalidate the warranty.
- ✓ Ensure the light is installed correctly in accordance with these instructions.
- ✓ Only install the light on a vertical surface. **DO NOT** fix the light on any horizontal surface i.e. ceiling, or overhang.
- ✓ Ideally the Installation should be away from flammable or combustible materials such as wood, cloth, paper etc.
- DANGER!** **DO NOT** direct the light into a persons eyes. This unit has a very intensive light output, which if incorrectly used could cause eye damage.
- x **DO NOT** install the light where it is likely to be knocked or hit.
- x **DO NOT** install in bathrooms, shower rooms, sauna or such locations.
- x **DO NOT** install near an exhaust outlet. i.e. Boiler flue, dryer outlet, etc.

- x **DO NOT** touch the light when operating, allow to cool before touching, light operates at high temperature.
- x **DO NOT** use the light without the front glass shield. Avoid touching the glass shield as handling may reduce its serviceable life and cause the glass to crack.
- x **DO NOT** use the light near flammable, combustible or explosive liquids, solids, gases or equipment.

2. INTRODUCTION

Motion detector unit automatically switches on when approached by vehicles or persons. Features 130 super bright LEDs, which have a longer working life than traditional halogen bulbs. Fitted with adjustable sensitivity and light duration controls. Mounted in die cast aluminium housing (painted black) with wall mounting bracket and full operating instructions. Suitable for outdoor use. Mains cable not supplied.

3. SPECIFICATION

Specifications:

Supply:.....220-240V 50Hz 1Ph.
Power:.....8Watt.
Protection Rating:.....IP44
Detection Angle:.....120° (Fan shape).
Detection Range:.....12m (Adjustable).
Time Delay:.....6 seconds to 20 minutes (Adjustable).
Light Sensitivity:.....30 Lux (Adjustable).

4. INSTALLATION INSTRUCTIONS

- WARNING!** **DO NOT** connect unit to the mains power supply before installation. When ready, the lamp must only be connected to the mains by a qualified electrician.
 - 4.1. **Fitting**
Give careful consideration to the position of unit to ensure you obtain maximum benefit from the lighting range, and that an appropriate electrical power source can be provided.
 - 4.1.1 **DO NOT** install near an exhaust outlet. i.e. Boiler flue, dryer outlet, etc as variance in temperature will effect the sensitivity of light. The light must be mounted on a vertical surface only i.e. on a wall etc. **DO NOT** mount on a horizontal surface i.e. ceiling or an overhang, **DO NOT** mount so that the face of the lamp is pointing upwards, or is facing towards the mounting surface. An approximate appropriate mounting height from the ground is 2.5m.
 - 4.1.2 This LED floodlight develops minimal heat and is not subject to the same mounting restrictions that apply to halogen lamps that become too hot to touch. We do however recommend that the floodlight should not be placed in cramped or restrictive positions and should be fixed at the following minimum distances between the light and any surface/object. See fig.2.
 - 500mm minimum between the top of the light and any overhead surface, or objects, i.e. ceilings, overhangs.
 - 200mm between sides of light and end or side walls, surface or objects.
 - 2 metres minimum between the front of the light and any object to be illuminated.
- Fix the light to vertical surface with appropriate fixings. Do not tilt the light back beyond 30° (fig 2B) or forward more than 45° (fig 2C).

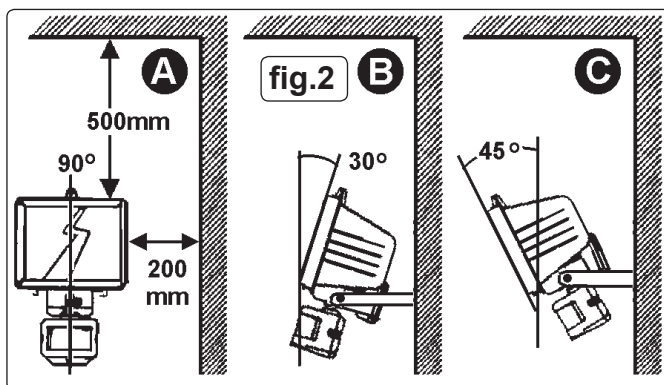

4.2. Sensor

The sensor may be angled independently of the light. Mounted at approximately 2.5m above the ground the sensor will have approx 12m range (fig 3) with a 120° spread (fig.4)

4.2.1 The sensor range can be reduced or optically adapted to local conditions by adjusting the sensor angle accordingly.

4.2.2 Further adjustment may be made by tuning the three switches located on the underside of the sensor as follows: (refer to fig.5).

Switch 1. Sensitivity. The sensor range will vary with temperature and factors such as passing cars, shade from large trees etc. During cold weather the sensor range will be greater than when hot in summer temperatures. For example during hot weather the forward detection range could fall from 12 to 6m and as such the sensor should be checked and adjusted. Note: the sensitivity factor is far greater when an object passes across the detection area (fig.4A) than when an object approaches towards the detector (B).

Switch 2. Time adjuster: To adjust the amount of time the light will stay on when activated. Minimum is 6 seconds, maximum is 20 minutes.

Switch 3. Daylight adjustment: To adjust the sensor to come on in accordance with the diminishing daylight. From 0 to 30 Lux.

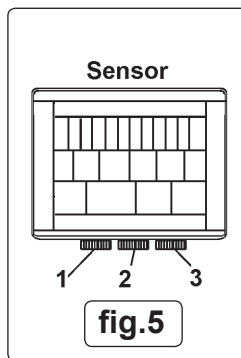
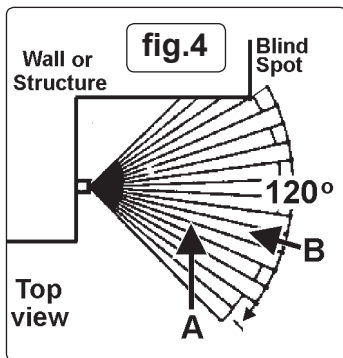
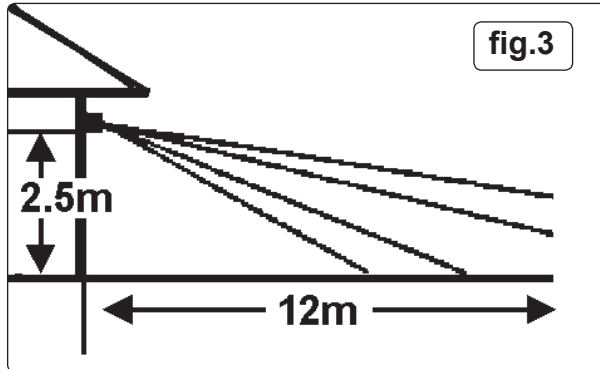

fig.6

4.3. GENERAL

Repairs must only be undertaken by a qualified electrician.

- 4.3.1 Clean the light with a dry, dust-free cloth. **DO NOT** use solvents, or abrasives to clean the light.
- 4.3.2 If necessary clean the glass shield (when cold) with alcohol and a soft cloth. If the glass is damaged, **DO NOT** use the light without the glass shield. (fig.6)
- 4.3.3 Although weather proof (IP44) the light must not be stored wet. Should the unit become wet, unplug from mains, wipe dry and store accordingly. **DO NOT** use the light without the weather seals intact.

Environmental Protection.



Recycle unwanted materials instead of disposing of them as waste.

All tools, accessories and packaging should be sorted, taken to a recycle centre and disposed of in a manner which is compatible with the environment.



When the product is no longer required, it must be disposed of in an environmentally protective way. Contact your local solid waste authority for recycling information.

NOTE: It is our policy to continually improve products and as such we reserve the right to alter data, specifications and component parts without prior notice.

IMPORTANT: No liability is accepted for incorrect use of this product.

WARRANTY: Guarantee is 12 months from purchase date, proof of which will be required for any claim.

INFORMATION: For a copy of our latest catalogue and promotions call us on 01284 757525 and leave your full name and address, including postcode.



Sole UK Distributor, Sealey Group,
Kempson Way, Suffolk Business Park,
Bury St. Edmunds, Suffolk,
IP32 7AR



01284 757500



www.sealey.co.uk



01284 703534



sales@sealey.co.uk