



INSTRUCTIONS FOR:

FOLDABLE UNDER BONNET LAMP 36 SMD LED 12V

MODEL NO: LED037.V2

Thank you for purchasing a Sealey product. Manufactured to a high standard, this product will, if used according to these instructions, and properly maintained, give you years of trouble free performance.



IMPORTANT: PLEASE READ THESE INSTRUCTIONS CAREFULLY. NOTE THE SAFE OPERATIONAL REQUIREMENTS, WARNINGS & CAUTIONS. USE THE PRODUCT CORRECTLY AND WITH CARE FOR THE PURPOSE FOR WHICH IT IS INTENDED. FAILURE TO DO SO MAY CAUSE DAMAGE AND/OR PERSONAL INJURY AND WILL INVALIDATE THE WARRANTY. KEEP THESE INSTRUCTIONS SAFE FOR FUTURE USE.

1. SAFETY

1.1. GENERAL

- WARNING!** Ensure Health and Safety, local authority and general workshop practice regulations are adhered to when using this light.
- WARNING!** Disconnect the lamp from the power supply before performing any maintenance on the lamp.
- DO NOT** use the lamp if the lamp is damaged, with risk of it falling.
- DO NOT** shine the lamp directly into your eyes, other person's eyes or animal's eyes.
- DO NOT** allow children to use the lamp.
- DO NOT** wear jewellery and tie back long hair when working beneath the engine bonnet.
- DO NOT** leave tools or any other extraneous items in or near the engine.
- Account for all tools being used.
- Wear approved eye protection when working beneath the engine bonnet. A full range of safety equipment is available from your Sealey dealer.
- Wear suitable clothing to avoid snagging.
- Maintain the lamp in good condition.
- When not in use store the lamp in a safe, dry, childproof location.

WARNING: The warnings, cautions and instructions discussed in this instruction manual cannot cover all possible conditions and situations that may occur. It must be understood that common sense and caution are factors which must be applied by the operator.

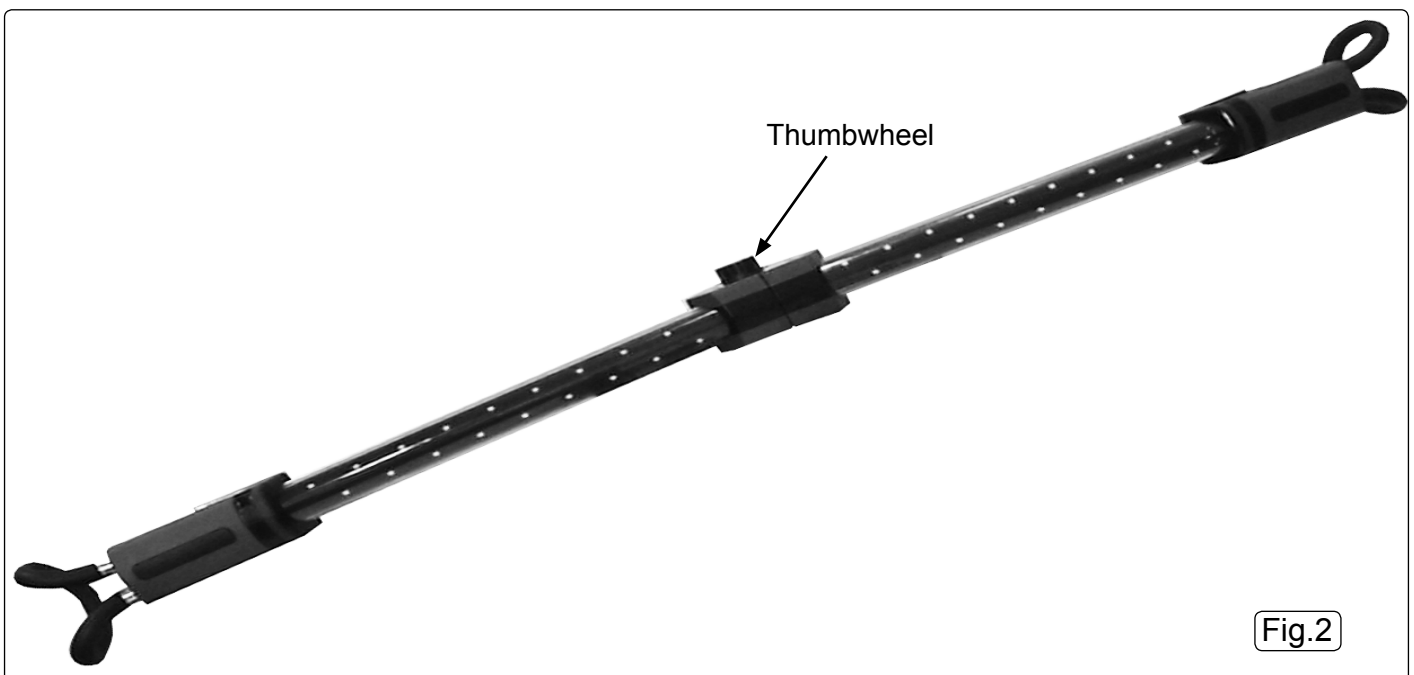
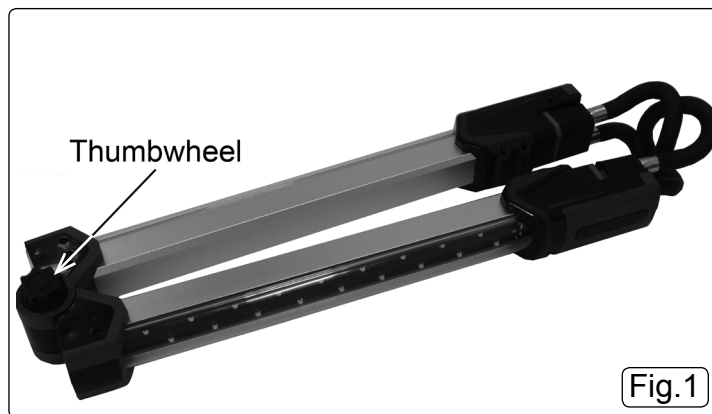

2. INTRODUCTION

Robust design with built-in spring loaded telescopic mounting brackets. Soft padded hooks provide good protection against the bonnet. 36 SMD LEDs and angled PCB give complete engine bay illumination with a 120° spread of light. Supplied with 5mtr of cable and battery terminal clips. Foldable design for easy storage when not in use.

3. SPECIFICATION

Model No: LED037.V2
Voltage: 12V
Power consumption: 7W
Fuse rating: 1A
Lamp type: 36 x 3528 SMD
Minimum/ maximum bonnet width 1230/1940mm

4. OPERATION

4.1. ATTACHING LAMP TO BONNET.

- 4.1.1. Unfold the lamp to straighten and tighten the thumbwheel (Fig.1 and Fig.2). Place the padded hook at the end of the lamp, over one edge of the bonnet and gently pull the lamp towards the other side of the bonnet.
- 4.1.2. Steady the lamp with one hand, whilst extending the hook over the other side of the bonnet.
- 4.1.3. To use the lamp, connect the red (positive) clamp to the battery first, followed by the black (negative) clamp, then turn on using the switch at the end.
- 4.1.4. When finished, disconnect the black (negative) clamp first, then the red (positive) one, fold the lamp and store it in a safe, dry and childproof location.

5 MAINTENANCE

- 5.1. Keep the lamp clean and check for damage before every use. If damage is observed, remove from use until unit is repaired.
- 5.2. If the lamp fails to operate, disconnect from the battery and check the fuse by pulling the lid off its cover (see Fig.3). Replace if necessary, refit the fuse cover and reconnect to the battery.

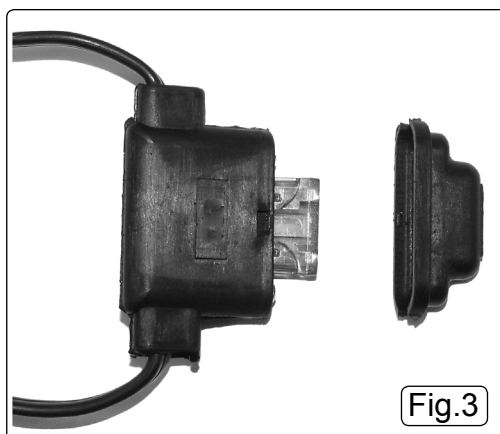

Parts support is available for this product. To obtain a parts listing and/or diagram, please log on to www.sealey.co.uk, email sales@sealey.co.uk or telephone 01284 757500.



Environmental Protection
Recycle unwanted materials instead of disposing of them as waste. All tools, accessories and packaging should be sorted, taken to a recycling centre and disposed of in a manner which is compatible with the environment.



WEEE Regulations
Dispose of this product at the end of its working life in compliance with the EU Directive on Waste Electrical and Electronic Equipment (WEEE). When the product is no longer required, it must be disposed of in an environmentally protective way. Contact your local solid waste authority for recycling information.

NOTE: It is our policy to continually improve products and as such we reserve the right to alter data, specifications and component parts without prior notice.

IMPORTANT: No liability is accepted for incorrect use of this product.

WARRANTY: Guarantee is 12 months from purchase date, proof of which will be required for any claim.

INFORMATION: For a copy of our latest catalogue and promotions call us on 01284 757525 and leave your full name and address, including postcode.



Sole UK Distributor, Sealey Group,
Kempson Way, Suffolk Business Park,
Bury St. Edmunds, Suffolk,
IP32 7AR



01284 757500



www.sealey.co.uk



01284 703534



sales@sealey.co.uk