



INSTRUCTIONS FOR:

# INFRA RED SPACE WARMERS

## Model: IRC153 & IRS153

Thank you for purchasing a Sealey product. Manufactured to a high standard this product will, if used according to these instructions and properly maintained, give you years of trouble free performance.

**IMPORTANT: PLEASE READ THESE INSTRUCTIONS CAREFULLY. NOTE THE SAFE OPERATIONAL REQUIREMENTS, WARNINGS & CAUTIONS. USE THE PRODUCT CORRECTLY AND WITH CARE FOR THE PURPOSE FOR WHICH IT IS INTENDED. FAILURE TO DO SO MAY CAUSE DAMAGE AND/OR PERSONAL INJURY AND WILL INVALIDATE THE WARRANTY. PLEASE KEEP INSTRUCTIONS SAFE FOR FUTURE USE.**

### 1. SAFETY INSTRUCTIONS

#### 1.1. ELECTRICAL SAFETY

**WARNING!** It is the responsibility of the owner and the operator to read, understand and comply with the following:

You must check all electrical products, before use, to ensure that they are safe. You must inspect power cables, plugs, sockets and any other connectors for wear or damage. You must ensure that the risk of electric shock is minimised by the installation of appropriate safety devices. A Residual Current Circuit Breaker (RCCB) should be incorporated in the main distribution board. We also recommend that a Residual Current Device (RCD) is used. It is particularly important to use an RCD with portable products that are plugged into a supply which is not protected by an RCCB. If in any doubt consult a qualified electrician. You may obtain a Residual Current Device by contacting your Sealey dealer.

**You must** also read and understand the following instructions concerning electrical safety.

- 1.1.1. The **Electricity at Work Act 1989** requires all portable electrical appliances, if used on business premises, to be tested by a qualified electrician, using a Portable Appliance Tester (PAT), at least once a year.
- 1.1.2. The **Health & Safety at Work Act 1974** makes owners of electrical appliances responsible for the safe condition of those appliances and the safety of the appliance operators. **If in any doubt about electrical safety, contact a qualified electrician.**
- 1.1.3. Ensure that the insulation on all cables and on the appliance is safe before connecting it to the power supply. See 1.1.1. and 1.1.2. and use a Portable Appliance Tester.
- 1.1.4. Ensure that cables are always protected against short circuit and overload.
- 1.1.5. Regularly inspect power supply cables and plugs for wear or damage and check all connections to ensure that none is loose.
- 1.1.6. **Important:** Ensure that the voltage marked on the appliance matches the power supply to be used and that the plug is fitted with the correct fuse - see fuse rating at right.
- 1.1.7. **DO NOT** pull or carry the appliance by the power cable.
- 1.1.8. **DO NOT** pull the plug from the socket by the cable.
- 1.1.9. **DO NOT** use worn or damaged cables, plugs or connectors. Immediately have any faulty item repaired or replaced by a qualified electrician. When an ASTA/BS approved UK 3 pin plug is damaged, cut the cable just above the plug and **dispose of the plug safely.** Fit a new plug according to the following instructions (UK only).

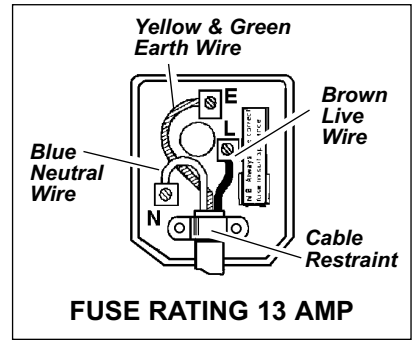

- a) Connect the GREEN/YELLOW earth wire to the earth terminal 'E'.
- b) Connect the BROWN live wire to the live terminal 'L'.
- c) Connect the BLUE neutral wire to the neutral terminal 'N'.

**d) After wiring, check that there are no bare wires, that all wires have been correctly connected, that the cable outer insulation extends beyond the cable restraint and that the restraint is tight.**

Double insulated products, which are always marked with this symbol , are fitted with live (brown) and neutral (blue) wires only. To rewire, connect the wires as indicated above - **DO NOT** connect either wire to the earth terminal.

- 1.1.10. If an extension reel is used it should be fully unwound before connection. A reel with an RCD fitted is preferred since any appliance plugged into it will be protected. The cable core section is important and should be at least 1.5mm<sup>2</sup>, but to be absolutely sure that the capacity of the reel is suitable for this product and for others which may be used in the other output sockets, we recommend the use of 2.5mm<sup>2</sup> section cable.

#### 1.2 GENERAL SAFETY

- WARNING!** These heaters use Light Technology, whereby quartz infrared elements heat objects by emitting energy at a level similar to the heat of the sun. **Any objects in the line of sight of the elements will start to feel warm**, the air in between is not heated. Traditional methods heat the air and rely on air circulation to transfer heat. As a result, quartz halogen heating can project heat over longer distances.
- WARNING!** Disconnect the heater from the mains power supply before carrying out any servicing or maintenance.
- ✓ Disconnect the heater from the power supply before handling or cleaning.
- ✓ Maintain the heater in good order and clean condition for best and safest performance.
- ✓ Maintain the cabinet in good condition. Replace or repair damaged parts. *Use genuine parts only. Unauthorised parts may be dangerous and will invalidate the warranty.*
- ✓ Locate heater in a suitable work area and keep area clean, tidy and free from unrelated materials. Ensure there is adequate lighting and keep the immediate area in front of the outlet grill clean.
- ✓ Only use the heater standing in the upright position on a level surface.
- ✗ **DO NOT** touch the lamp filament, even when cold.
- ✗ **DO NOT** use the heater without the guards fitted.
- ✗ **DO NOT** use the heater without the wheels fitted and locked.
- ✗ **DO NOT** allow the heater to get wet as this may cause an electric shock, causing damage to the heater and possible personal injury.
- ✗ **DO NOT** let power lead hang over an edge (i.e. table), or touch a hot surface, lie in the beam of heat, or run under a carpet.
- ✗ **DO NOT** cover heater when in use, and do not obstruct the air inlet and outlet grilles.
- ✗ **DO NOT** use in bathroom, shower room, or in any wet or damp environments or where there is high condensation.
- ✗ **DO NOT** operate the heater when you are tired or under the influence of alcohol, drugs or intoxicating medication.
- ✗ **DO NOT** insert or allow objects to enter any openings of heater as this may cause an electric shock, fire or damage to heater.
- ✗ **DO NOT** use the heater out of doors. These heaters are designed for indoor use only.
- ✗ **DO NOT** use heater if the power cord, plug or the heater is damaged, or if the heater has become wet.
- ✗ **DO NOT** use the heater where there are flammable liquids, solids or gases such as petrol, solvents, aerosols etc, or where heat sensitive materials may be stored.
- ✗ **DO NOT** place the heater near items that may be damaged by heat, allow at least 2m clearance in front of the heater.
- ✗ **DO NOT** touch the outlet grille of the heater during and immediately after use as it will be hot.
- ✗ **DO NOT** allow children to touch or to operate the heater.
- ✗ **DO NOT** place heater too close to yourself or any object, allow the air to circulate freely.
- ✗ **DO NOT** use the heater for any purpose other than for which it is designed.
- ✓ Allow the unit to cool before storage. When not in use, disconnect from the mains power supply and store in a safe, cool, dry, childproof area.



IRS153



## 2. INTRODUCTION AND SPECIFICATIONS

### 2.1. Introduction

2.1.1. Powder coated metal cabinet with 2 quartz infra-red elements and chemically polished reflectors for maximum heat emission. Controllable power output by rocker switches on the side/back of the cabinet. Features easy-rolling swivel castors with 2 locking castors. Suitable for wide range of personnel warming and restorative applications. Supplied with cable and BS/ASTA approved plug.

### 2.1. Specification

IRC153  
 Power output (2 heat settings) .....TOTAL 3000 Watt  
 Size W X D X H .....530 x 560 x 960mm  
 Weight .....18Kg  
 Voltage .....230V (50Hz)

IRS153  
 Power output (2 heat settings) .....TOTAL 3000 Watt  
 Size W X D X H .....610 x 680 x 850mm  
 Weight .....13Kg  
 Voltage .....230V (50Hz)

## 3. ASSEMBLY

### 3.1. IRC153 - Fig.1.

- 3.1.1. Attach the wheel sub-assemblies to the base of the heater using the bolts provided ensuring the lockable wheels are to the rear of the heater.
- 3.1.2. Attach the handle to the top of the heater using the bolts provided, ensuring the shaped spacers are fitted between the heater and the handle as shown.
- 3.1.3. Remove the front grille retaining screws and remove the protective packing fitted between the lamps and the reflectors.
- 3.1.4. Refit the front grille using the four retaining screws.

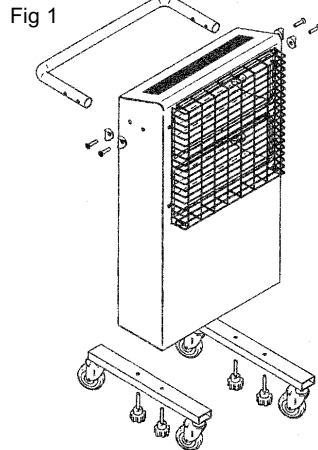

### 3.1. IRS153 - Fig.2.

- 3.1.1. Fit the handle section of the support frame to the wheel section ensuring the fixing holes align.
- 3.1.2. Fit the heater to the support frame using the bolts provided, ensuring the shaped spacers are fitted either side of the frame as shown. Tighten the bolts sufficiently to retain the heater at the required angle.
- 3.1.3. Remove the front grille retaining screws and remove the protective packing fitted between the lamps and the reflectors.
- 3.1.4. Refit the front grille using the four retaining screws.

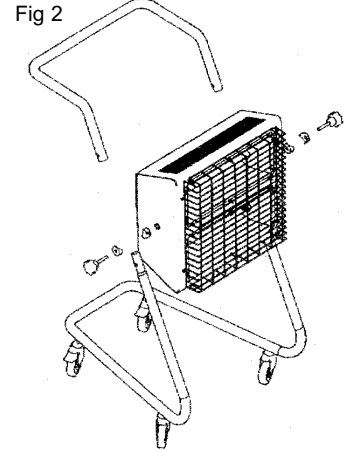

## 4. HEATER OPERATION

### 4.1. Operating the heater.

- 4.1.2. Place the heater on a level floor in a suitable position in the area you require to heat. Allow a minimum of 2M between the heater and adjacent objects.
- 4.1.3. Plug the heater into the mains supply.
- 4.1.4. Select the required output by using the two rocker switches (on the side of the IRC153 and on the back of the IRS153) which switch the lamps on and off. Each lamp has an output of 1500W.
- 4.1.5. To switch the unit off, select "0" on both the rocker switches and unplug from the mains. Allow the unit to cool before handling or storage.

**WARNING!** DO NOT touch the top of the heater when in use as it becomes hot.

## 5. MAINTENANCE

- WARNING!** Before attempting any maintenance ensure the unit is unplugged from the mains power supply, that it is cool and it is on level ground.
- x** DO NOT touch the lamp filament, even when cold.
- x** DO NOT use the heater without the guards fitted.

### 5.1. Cleaning.

- 5.1.1. To clean the reflector, remove the guard by unscrewing the retaining screws and wipe the reflector with a clean dry cloth. DO NOT use abrasives or solvents. The surface of the reflector is very soft and scratches may cause it to overheat. Replace the guard.

### 5.2. Changing a lamp.

- WARNING!** Lamps should only be changed by a qualified electrician.
- 5.2.1. Remove the front grille by unscrewing the retaining screws.
  - 5.2.2. Remove the side reflectors by unscrewing the retaining screws.
  - 5.2.3. Ease the spring clips on the ends of the lamp and pull the lamp forward such that it clears the edge of the clips but is still retained in the clips.
  - 5.2.4. Remove the back panel of the unit by unscrewing the retaining screws.
- Note: The back panel of the IRC153 provides rigidity when fitted. Removal of the back panel renders the heater unstable.
- 5.2.5. Disconnect the lamp supply leads from the switch inside the heater.
  - 5.2.6. Remove the lamp from the spring clips.
  - 5.2.7. Fitting the new lamp is the reverse of paragraphs 5.2.1. to 5.2.6.

**Declaration of Conformity** We, the sole importer into the UK, declare that the products listed here are in conformity with the following standards and directives.

**INFRA RED SPACE WARMERS**  
**Models: IRC153 & IRS153**  
 73/23/EEC Low Voltage Directive  
 89/336/EEC EMC Directive

The construction file for these products is held by the Manufacturer and may be inspected, by a national authority, upon request to Jack Sealey Ltd.



Signed by Mark Sweetman

2nd May 2002

For Jack Sealey Ltd. Sole importer into the UK of Sealey Power Products.

**NOTE:** It is our policy to continually improve products and as such we reserve the right to alter data, specifications and component parts without prior notice.

**IMPORTANT:** No liability is accepted for incorrect use of product.

**WARRANTY:** Guarantee is 12 months from purchase date, proof of which will be required for any claim.

**INFORMATION:** For a copy of our latest catalogue and promotions call us on 01284 757525 and leave your full name and address, including postcode.



Sole UK Distributor  
 Sealey Group,  
 Bury St. Edmunds, Suffolk.



01284 757500



01284 703534

E-mail: sales@sealey.co.uk