

# SEALEY

## 125,000BTU/HR SPACE WARMER® KEROSENE/ DIESEL HEATER WITH WHEELS

MODEL NO: IR37.V5

Thank you for purchasing a Sealey product. Manufactured to a high standard, this product will, if used according to these instructions, and properly maintained, give you years of trouble free performance.

**IMPORTANT:** PLEASE READ THESE INSTRUCTIONS CAREFULLY. NOTE THE SAFE OPERATIONAL REQUIREMENTS, WARNINGS & CAUTIONS. USE THE PRODUCT CORRECTLY AND WITH CARE FOR THE PURPOSE FOR WHICH IT IS INTENDED. FAILURE TO DO SO MAY CAUSE DAMAGE AND/OR PERSONAL INJURY AND WILL INVALIDATE THE WARRANTY. KEEP THESE INSTRUCTIONS SAFE FOR FUTURE USE.



Refer to  
Instruction  
Manual



Wear  
Protective gloves  
(refuelling)



Warning!  
Hot surface



DO NOT use  
petrol

**! DANGER**



Use heater in well  
ventilated areas



Always unplug  
heater before  
servicing and  
checking

**! DANGER**



Never use heater  
where highly  
flammable vapours  
are present

**THIS HEATER IS NOT SUITABLE FOR USE AS A PRIMARY HEATING SOURCE**

### 1. SAFETY

#### 1.1. ELECTRICAL SAFETY

- **WARNING!** It is the user's responsibility to check the following:  
Check all electrical equipment and appliances to ensure that they are safe before using. Inspect power supply leads, plugs and all electrical connections for wear and damage. Sealey recommend that an RCD (Residual Current Device) is used with all electrical products. You may obtain an RCD by contacting your local Sealey stockist.  
If the product is used in the course of business duties, it must be maintained in a safe condition and routinely PAT (Portable Appliance Test) tested.

Electrical safety information, it is important that the following information is read and understood.

Ensure that the insulation on all cables and on the appliance is safe before connecting it to the power supply.

Regularly inspect power supply cables and plugs for wear or damage and check all connections to ensure that they are secure.

**Important:** Ensure that the voltage rating on the appliance suits the power supply to be used and that the plug is fitted with the correct fuse - see fuse rating in these instructions.

- \* **DO NOT** pull or carry the appliance by the power cable.
- \* **DO NOT** pull the plug from the socket by the cable.
- \* **DO NOT** use worn or damaged cables, plugs or connectors. Ensure that any faulty item is repaired or is replaced immediately by a qualified electrician.

This product is fitted with a BS1363/A 13 Amp 3 pin plug.

If the cable or plug is damaged during use, switch off the electricity supply and remove from use.

Ensure that repairs are carried out by a qualified electrician.

Replace a damaged plug with a BS1363/A 13 Amp 3 pin plug. If in doubt contact a qualified electrician.

a) Connect the GREEN/YELLOW earth wire to the earth terminal 'E'.

b) Connect the BROWN live wire to the live terminal 'L'.

c) Connect the BLUE neutral wire to the neutral terminal 'N'.

Ensure that the cable outer sheath extends inside the cable restraint and that the restraint is tight.

Sealey recommend that repairs are carried out by a qualified electrician.

- 1.1.1. If an extension reel is used it should be fully unwound before connection. A reel with an RCD fitted is preferred since any appliance plugged into it will be protected. The cable core section is important and should be at least 1.5mm<sup>2</sup>, but to be absolutely sure that the capacity of the reel is suitable for this product and for others which may be used in the other output sockets, we recommend the use of 2.5mm<sup>2</sup> section cable.

#### 1.2. GENERAL SAFETY

- ▲ **DANGER!** Risk of carbon monoxide poisoning. Failure to provide proper ventilation could result in serious illness or death.
- ✓ Check that the heater is in sound condition and good working order. *Take immediate action to repair or replace damaged parts.*
- ✓ Use recommended parts only. *Unauthorised parts may be dangerous and will invalidate the warranty.*
- ✓ Only use clean paraffin, diesel (NOT BIO-DIESEL) or kerosene to fuel this heater, in accordance with instructions contained in this manual.
- ✓ Locate heater on a level and stable surface.
- ✓ Switch off if any irregularities occur.
- **! WARNING!** Only use heater in well ventilated areas. Ensure continuous ventilation is provided to the heater operating area via windows and doors etc. If people are not required to be present in the heated area, the volume of air to be heated (mtr<sup>3</sup>)/heat output (kW) ratio must be at least 10:1 and people must be advised not to remain in the heated area for prolonged periods. If people are required to be present in the heated area, the volume of air to be heated (mtr<sup>3</sup>)/heat output (kW) ratio must be at least 30:1. Ventilation must be to the outside of the premises in which the heater is to be operated. The total open area (mtr<sup>2</sup>) must be at least 0.003 times the total heat output (kW). The volume concentration of oxygen (O<sup>2</sup>) in the heated room, must always remain above 17%.
- **WARNING! DO NOT** use the heater near flammable material, liquids, solids, gases or compressed gas cylinders etc.
- \* **DO NOT** switch the heater off by disconnecting it from the mains. **ALWAYS** set the switch on the burner to the 'OFF' position and allow the cooling cycle to finish, before disconnecting from the mains.

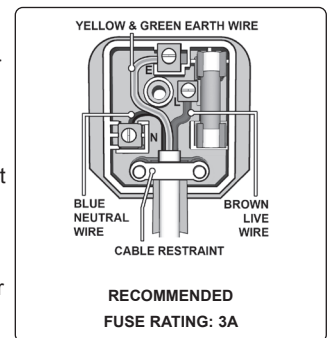

- ✗ **DO NOT** stand or place **any** object less than 3m from the heater output and keep the heater a minimum of 2m from any walls or objects.
  - ✗ **DO NOT** use the heater in closed rooms, living areas, basements or below ground level.
  - ✗ **DO NOT** allow untrained persons to operate the heater and **DO NOT** operate the heater without the safety guard.
  - ✗ **DO NOT** move or handle the heater when hot, without wearing protective gloves. Never move the heater whilst it is operating.
  - ✗ **DO NOT leave the heater unattended for prolonged periods of time when in use.** Switch the heater off and unplug from the mains before leaving work area.
  - ✗ **DO NOT** fill the fuel tank whilst the heater is running or still hot. **DO NOT** overfill the fuel container. Wipe up any spilt fuel immediately.
  - ✗ **DO NOT** obstruct the air inlet (rear) and air outlet (front) of the heater and **DO NOT** use duct work in front or at the rear of the heater.
  - ✗ **DO NOT** allow children or animals near the heater when in use, or whilst still hot.
  - ☐ **WARNING! RISK OF ELECTRIC SHOCK. DO NOT** expose the heater to water spray, rain, dripping water or wind.
  - ✗ **DO NOT** operate the heater when you are tired or under the influence of alcohol, drugs or intoxicating medication.
  - ✗ **DO NOT** touch the heater outlet or cone when in use, or for a period of time after it's switched off, as these are **VERY** hot and will take time to cool down.
  - ✗ **DO NOT** use an external fuel tank. Only use the tank that is fitted to the heater, and only fill it when the heater has cooled down.
  - ✓ Ensure that the heater is correctly turned off.
  - ✓ When not in use for an extended period, store in a safe, dry area, out of reach of children.
- Important:** This appliance is not intended for persons (including children) with reduced physical, sensory or mental capabilities, or lack of experience and knowledge, unless they have been given supervision or instruction concerning use of the appliance by a person responsible for their safety. Children should be supervised to ensure that they do not play with the appliance.

## 2. INTRODUCTION

Versatile multi-fuel heater designed to run on paraffin, kerosene or diesel. Clean burning unit suitable for well-ventilated applications. 53L Tank allows approximately 20hrs running time, making this unit extremely economical. Safety features include automatic overheat safety shut-off and quiet operation.

## 3. SPECIFICATION

Model	IR37.V5
Fuel Tank	53L
Fuel	Paraffin/Kerosene/Diesel
Heated Area	25,000ft <sup>2</sup> (708m <sup>2</sup> )
Output	95,000Btu/hr(20.5kW)/125,000Btu/hr(37kW)
Running time Per Filling (Maximum)	20hr
Supply	230V

☐ **WARNING!** *This heater is not suitable for use with Bio-Diesel; use of Bio-Diesel will damage the filter and seals. Damage caused by use of Bio-Diesel will not be covered by warranty.*

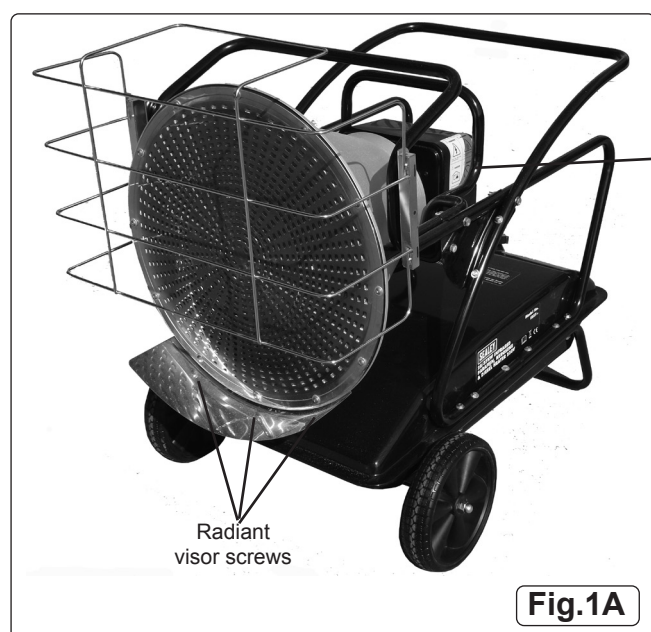

**Fig.1A**

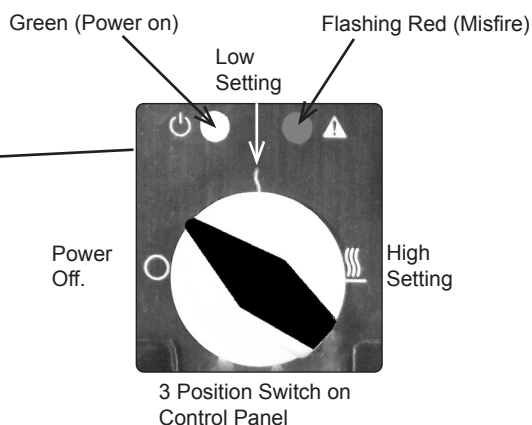

Tips on ignition:-  
 The photocell is sensitive to sunlight, ignite in the shade.  
 Listen for fan followed by pump, after switch position " **↓** "  
 Priming essential when new, see 5.3.4.  
 Observe the fuel level in the filter bowl.  
 Clean fuel requires clean reservoir and clean transfer cans.



Fig.1B

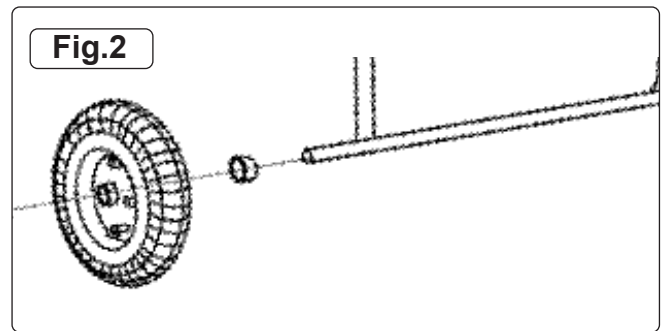

Fig.2

Fuel Gauge and Filler Cap

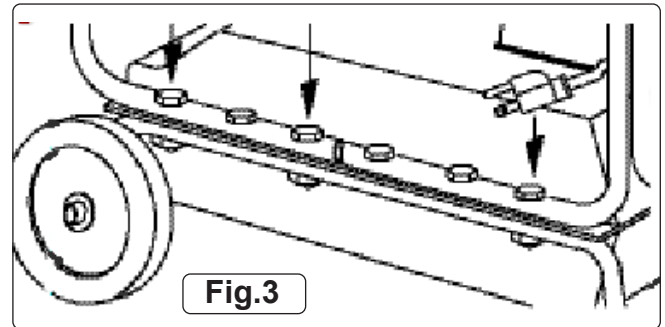

Fig.3

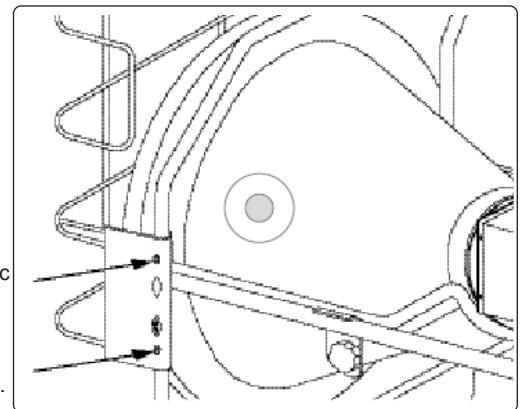

Fig.4

## 4. ASSEMBLY

- 4.1. Remove front guard from packed/transit position.
- 4.2. Slide axle through wheel frame place on spacer, wheel then nut, see fig.2.
- 4.3. Place main structure on Wheel Frame and fasten with nuts, Bolts and washers provided, see fig.3.
- 4.4. Attach safety guard to front of heater with bolts provided, see fig.4
- 4.5. Fit radiant visor to bottom 3 screws of radiant cone assembly, see fig.1A.

## 5. OPERATION

- ❑ **WARNING!** This heater is not suitable for use with Bio-Diesel; use of Bio-Diesel will damage the filter and seals. **Damage caused by use of Bio-Diesel will not be covered by warranty.**
- 5.1. **PRINCIPLES OF OPERATION**
- 5.1.1. **Fuel System:** This heater is equipped with an air pump that operates off the electric motor. The pump forces air through the air line connected to the fuel tank, drawing fuel to the nozzle. Air also passes through the nozzle where it mixes with the fuel and is sprayed into the combustion chamber as a fine mist.
  - 5.1.2. **Quick-Fire Ignition:** A transformer sends high voltage to a two pronged spark plug.
  - 5.1.3. The spark ignites the fuel/air mixture as it is sprayed into the combustion chamber.
  - 5.1.4. **Air System:** A fan is turned by the heavy duty motor, which forces air around and into the combustion chamber, where it is super-heated and forced out the front of the chamber.
  - 5.1.5. **Electrical System Protection:** The heater's electrical system is protected by a circuit breaker that protects the system components from damage. If the heater fails, check the fuse first, and replace if necessary.
  - 5.1.6. **Flame Sensor:** The heater uses a photocell to see the flame in the combustion chamber. Should the flame extinguish, the sensor will stop electrical current and the heater will shut off.
  - 5.1.7. **Tip-over Sensor:** The heater uses a tip-over sensor.
  - 5.1.8. **Fuel:** the heater operates with paraffin, kerosene or diesel fuel. **DO NOT use any other type of fuel.**
  - 5.1.9. When used in the construction or agricultural industries ensure that the safety regulations in force are adhered to with regard to distances from flammable materials and any other specified substances.
- ❑ **WARNING!** Air contaminants taken into the heater may affect the heat output, damage the unit and may cause health problems. **Example: Bodyshop filler dust/paint overspray will damage the motor bearing, clog the filter and compressor and contaminate the combustion chamber causing flame flutter and health hazards. Please note that any parts damaged by filler dust/paint overspray will not be covered by warranty. Additionally, a cleaning charge will be made for any heaters damaged by filler dust/paint over spray.**
- 5.2. **VENTILATION:**
- ❑ **WARNING! Only use the heater in well ventilated areas.** Careful consideration must be given to the placing of the heater to provide safe and comfortable heating. Ensure continuous ventilation is provided to the heater operating area. A ventilation opening must run to the outside of the premises in which the heater is to be operated. **The heater requires a fresh air opening of at least 2800cm<sup>2</sup>.**  
For Example:
    - A two car garage door should be open at least 11cm.
    - A single car garage door should be open at least 16cm.
    - Two 76cm windows should be open at least 20cm.
- 5.3. **STARTING THE HEATER**
- NOTE: If air has entered the fuel line; possible when new, when left standing for a long period or when the tank level has fallen too low, priming may be necessary (see 5.3.4). It is preferable to start the heater outdoors for the first time, to allow any oils left over from the manufacturing process and transporting to be burnt off in a safe environment. Run it for 10 minutes on this first burn.**
- 5.3.1. Carefully fill the fuel tank with clean approved fuel until fuel gauge (Fig.1B) points to 'F'.
  - 5.3.2. Ensure the fuel cap is secure.
  - 5.3.3. Plug the power cord into a suitable power socket. If using an extension lead see Electrical Safety section 1.1.

- 5.3.4. Turn the power knob in Fig.1 from "O" to the "1" setting. The green "power indicator" lamp will illuminate, the fan will run followed in 15 seconds by the pump. Inside the next 30 seconds the heater will ignite. If the heater does not ignite the red "Misfire" lamp will illuminate and flash after 3 attempts. Switch the unit off "O" and wait approximately 20 seconds before attempting to ignite again; this 20 seconds will allow the PCB to recalibrate. On successful ignition, if required, increase the heat by turning the knob to setting "55".
- 5.3.5. When switching from one heat level to another during operation, it may cease operating and go into the misfire sequence. If this happens, turn the power knob to the "O" position and immediately turn it to the desired heat level.  
**NOTE:** The electrical components of this heater are protected by a fuse mounted in the PCB. If the heater fails to fire, check this fuse first, and replace if necessary. Also check the power source to ensure that the correct voltage is being provided to the heater.
- 5.4. TILTING FEATURE**
- 5.4.1. Loosen the hand screws on the main frame of the heater, position the heater in the desired position and tighten the hand screws to secure the heater in the tilted position.
- 5.5. TO STOP THE HEATER**
- 5.5.1. Turn the power knob to the "O" position, the green "power indicator" will go off. Combustion will stop, and the Cooling Cycle (approx. 5 minutes in duration) will begin.
- 5.5.2. When the Cooling Cycle is completed (fan stops running), it is safe to unplug the heater.  
 **WARNING! Unplugging the heater before the Cooling Cycle has finished may cause overheating, possible damage to the heater and heat plate, and will invalidate the warranty.**
- 5.6. TO RESTART THE HEATER**
- 5.6.1. Wait ten seconds after the cooling cycle has completed.
- 5.6.2. Turn the power knob to the position and wait 10 seconds before adjusting heat level if required.
- 5.6.3. Be sure to follow all starting procedure precautions.

## 6. MAINTENANCE

Use only original equipment replacement parts. **Isolate power before any maintenance. The use of alternate or third party components can cause unsafe operating conditions, and will invalidate the warranty. We suggest following a maintenance schedule as follows.**

- 6.1. FUEL/FUEL TANK** - Flush every 200 hours of operation or as needed. **DO NOT** use water to flush the tank. Use fresh kerosene/paraffin/diesel only.
- 6.2. FILTERS** - The Fuel Filter and Oil Filter should be cleaned at least twice per heating season by rinsing them in clean kerosene/paraffin/diesel. This procedure should also be followed if the fuel is found to be contaminated (Fig.5).
- 6.3. NOZZLE** - Nozzles should be cleaned or replaced at least once per heating season. This procedure should also be followed if the fuel is found to be contaminated.
- 6.3.1. To clean dirt from nozzle, blow compressed air through nozzle front. It may be necessary to soak the nozzle in clean kerosene/paraffin/diesel to help loosen any particles (Fig.6).
- 6.4. SPARK PLUG** - Clean and re-gap every 600 hours of operation, or replace as needed (Fig.7).
- 6.4.1. After removing the Spark Plug, clean the terminals with a wire brush.
- 6.5. PHOTOCELL** - The Photocell should be cleaned at least once per heating season or more depending on conditions.
- 6.5.1. **⚠ Isolate power** before using a cotton swab dipped in water or alcohol to clean the lens of the Photocell (Figs.8 and 9).
- 6.6. LONG TERM STORAGE**
- 6.6.1. Unscrew the Drain Bolt and drain fuel into a suitable container (Fig.10).
- 6.6.2. Using a small amount of kerosene/paraffin/diesel, rinse and swirl the fuel around the fuel tank. Empty the tank completely.
- 6.6.3. **Never store leftover kerosene/paraffin/diesel over the summer. Using old fuel can damage the heater.**
- 6.6.4. Store heater in a dry, well ventilated area.
- 6.6.5. Be sure that the storage area is free of dust and corrosive vapours. Repack the heater in the original shipping material. **Keep this User's Manual in an easily accessible place.**

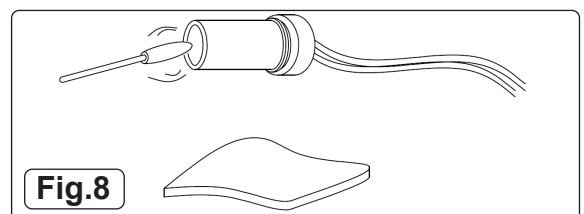
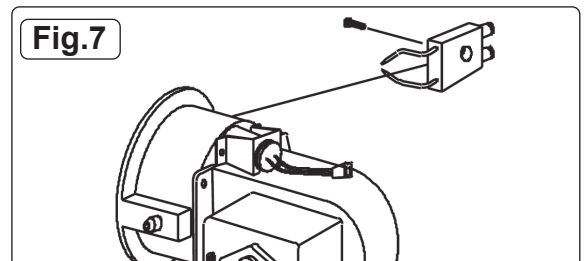
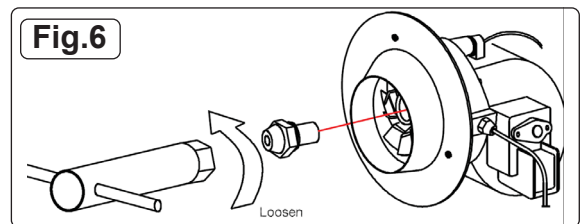
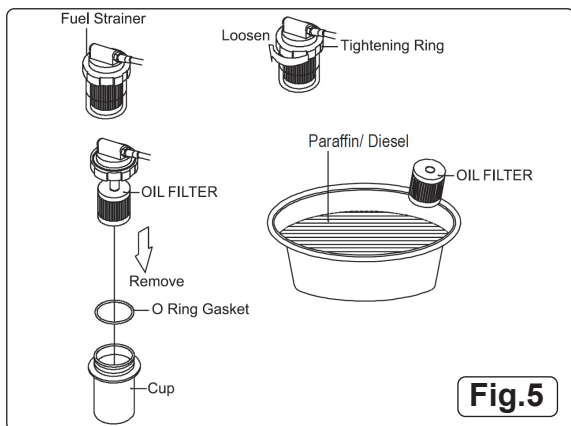

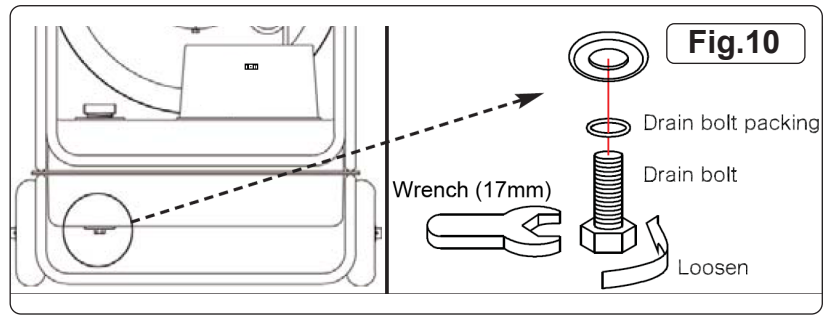
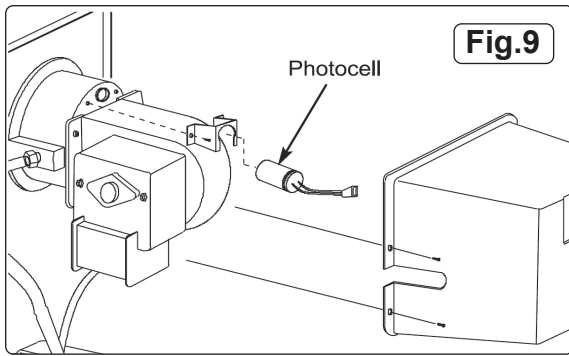

## 7. TROUBLESHOOTING

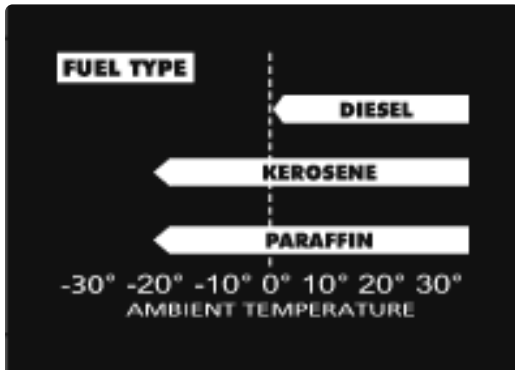

Although this heater operates with diesel fuel, when the temperatures are below 0°C, diesel additives are required to maintain the diesel's viscosity. Typically diesel can cloud in freezing conditions and will start to gel. You will need additives for your fuel in these conditions. Kerosene/Paraffin does not start to gel until the ambient temperature is around -40°C.

Problem	Possible Cause	Solution
Heater fires, but shuts down after a short period of time.	1. Dirty fuel filter.	1. Clean/replace fuel filter.
	2. Nozzle dirty.	2. Clean/replace nozzle.
	3. Photocell dirty.	3. Clean/replace photocell.
	4. Photocell not installed properly.	4. Adjust photocell position.
	5. Photocell defective.	5. Replace photocell.
	6. Improper electrical connection between circuit board and photocell.	6. Check wiring connections
	7. Cooling fan is obstructed.	7. Check to make sure cooling fan is not obstructed.
Heater will not operate, or motor runs for short time.	1. No fuel in fuel tank.	1. Fill tank with fresh fuel.
	2. Corroded spark plug or incorrect plug gap.	2. Clean/replace spark plug.
	3. Dirty fuel filter.	3. Clean/replace fuel filter.
	4. Dirty nozzle.	4. Clean/replace nozzle.
	5. Moisture in fuel/fuel tank.	5. Rinse out fuel tank and fill with clean fresh fuel.
	6. Improper electrical connection between transformer and circuit board.	6. Inspect all electrical connections.
	7. Transformer wires not connected to spark plug.	7. Re-attach transformer wires to spark plug.
	8. Defective transformer.	8. Replace transformer.
Fan does not operate when heater is plugged in and power switch is in the "I" position.	1. Broken electrical connection between circuit board and motor.	1. Inspect all electrical connections.
	2. Not enough amps available to power heater.	2. Use a new extension cord or try another electrical socket.
Heater does not turn on and the lamp is not lit.	1. Temperature limit sensor has overheated.	1. Turn power knob to "O" and allow heater to cool for 5 minutes. Turn power knob back to "I".
	2. No electrical power.	2. Check power cord and extension cord to ensure proper connection. Test power supply.
	3. Fuse break down.	3. Check/replace use.
	4. Improper electrical connection between temperature limit sensor and circuit board.	4. Inspect all electrical connections.
Poor combustion and / or soot production.	1. Incorrect pump pressure.	1. Ensure pump pressure is adjusted correctly.
	2. Poor fuel quality.	2. Ensure fuel is not old or contaminated.



#### ENVIRONMENT PROTECTION

Recycle unwanted materials instead of disposing of them as waste. All tools, accessories and packaging should be sorted, taken to a recycling centre and disposed of in a manner which is compatible with the environment. When the product becomes completely unserviceable and requires disposal, drain any fluids (if applicable) into approved containers and dispose of the product and fluids according to local regulations.



#### WEEE REGULATIONS

Dispose of this product at the end of its working life in compliance with the EU Directive on Waste Electrical and Electronic Equipment (WEEE). When the product is no longer required, it must be disposed of in an environmentally protective way. Contact your local solid waste authority for recycling information.

**Note:** It is our policy to continually improve products and as such we reserve the right to alter data, specifications and component parts without prior notice. If you require documentation for alternative versions, please email or call our technical team on [technical@sealey.co.uk](mailto:technical@sealey.co.uk) or 01284 757505.

**Important:** No Liability is accepted for incorrect use of this product.

**Warranty:** Guarantee is 12 months from purchase date, proof of which is required for any claim.

Sealey Group, Kempson Way, Suffolk Business Park, Bury St Edmunds, Suffolk. IP32 7AR



01284 757500



01284 703534



[sales@sealey.co.uk](mailto:sales@sealey.co.uk)



[www.sealey.co.uk](http://www.sealey.co.uk)



## Information requirements for gaseous/liquid fuel local space heaters

Model identifier(s): IR37.V5										
Indirect heating functionality:    Yes            No <input checked="" type="checkbox"/>										
Direct heat output:    36.6    (kW)				Indirect heat output:    N/A    (kW)						
<b>Fuel</b>						Space heating emissions NO <sub>x</sub> nitrogen oxides				
Select fuel type:	Gaseous	Liquid <input checked="" type="checkbox"/>	Specify: Diesel			118.2    [mg/kWh <sub>input</sub> ] (GCV)				
Item	Symbol	Value	Unit	Item	Symbol	Value	Unit			
<b>Heat output</b>				<b>Useful efficiency (NCV)</b>						
Nominal heat output	$P_{nom}$	38.1	kW	Useful efficiency at nominal heat output	$\eta_{th,nom}$	90.5	%			
Minimum heat output (indicative)*	$P_{min}$	28.1	kW	Useful efficiency at minimum heat output (indicative)*	$\eta_{th,min}$	N/A	%			
<b>Auxiliary electricity consumption</b>				<b>Type of heat output/room temperature control (select one)</b>						
At nominal heat output	$e_{l,max}$	0.084	kW	Single stage heat output, no room temperature control	Yes	No <input checked="" type="checkbox"/>				
At minimum heat output	$e_{l,min}$	0.075	kW	Two or more manual stages, no room temperature control	Yes <input checked="" type="checkbox"/>	No				
In standby mode	$e_{l,SB}$	N/A	kW	With mechanical thermostat room temperature control	Yes	No <input checked="" type="checkbox"/>				
* Enter figure or NA				With electronic room temperature control	Yes	No <input checked="" type="checkbox"/>				
				With electronic room temperature control plus day timer	Yes	No <input checked="" type="checkbox"/>				
				With electronic room temperature control plus week timer	Yes	No <input checked="" type="checkbox"/>				
				<b>Other control options (multiple selections possible)</b>						
				Room temperature control, with presence detection	Yes	No <input checked="" type="checkbox"/>				
				Room temperature control, with open window detection	Yes	No <input checked="" type="checkbox"/>				
				With distance control option	Yes	No <input checked="" type="checkbox"/>				
				With adaptive start control	Yes	No <input checked="" type="checkbox"/>				
<b>Permanent pilot flame power requirement</b>				With working time limitation	Yes	No <input checked="" type="checkbox"/>				
Pilot flame power required (if applicable)*	$P_{pilot}$	N/A	kW	With black bulb sensor	Yes	No <input checked="" type="checkbox"/>				
<b>The seasonal space heating energy efficiency <math>\eta_s</math></b>										
Item				Symbol		Value		Unit		
The seasonal space heating Energy efficiency in active mode				$\eta_{s,on}$		100		%		
The seasonal space heating energy efficiency $\eta_s$				$\eta_s$		90.5		%		
<b>Energy efficiency classes</b>				A						
Contact details: Sealey Group, Kempson Way, Suffolk Business Park, Bury St Edmunds, Suffolk, IP32 7AR.    www.sealey.co.uk										
v1						ERP Table 1				