



3150W INFRARED PANEL DRYER WITH DISTANCE SENSOR - SHORT WAVE

MODEL NO: IR3000.V3

Thank you for purchasing a Sealey product. Manufactured to a high standard, this product will, if used according to these instructions, and properly maintained, give you years of trouble free performance.

IMPORTANT: PLEASE READ THESE INSTRUCTIONS CAREFULLY. NOTE THE SAFE OPERATIONAL REQUIREMENTS, WARNINGS & CAUTIONS. USE THE PRODUCT CORRECTLY AND WITH CARE FOR THE PURPOSE FOR WHICH IT IS INTENDED. FAILURE TO DO SO MAY CAUSE DAMAGE AND/OR PERSONAL INJURY AND WILL INVALIDATE THE WARRANTY. KEEP THESE INSTRUCTIONS SAFE FOR FUTURE USE.



Refer to instruction manual



Warning: Electricity



Warning: Hot Surface



Indoor Use Only



Keep away from flammable substances during operation



Unplug before cleaning

1. SAFETY

1.1. ELECTRICAL SAFETY

- **WARNING! It is the owner's responsibility to read, understand and comply with the following:**

You must check all electrical equipment and appliances to ensure that they are safe before use. You must inspect power supply leads, plugs and all electrical connections for wear and damage. You must ensure the risk of electric shock is minimised by the installation of appropriate safety devices. An RCCB (Residual Current Circuit Breaker) should be incorporated in the main distribution board. We also recommend that an RCD (Residual Current Device) is used with all electrical products. It is particularly important to use an RCD with portable products that are plugged into an electrical supply not protected by an RCCB. If in doubt consult a qualified electrician. **You must** also read and understand the following instructions concerning electrical safety.
- 1.1.1. **The Electricity At Work Act 1989** requires all portable electrical appliances, if used on business premises, to be tested by a qualified electrician, using a Portable Appliance Tester (PAT), at least once a year.
- 1.1.2. **The Health & Safety at Work Act 1974** makes owners of electrical appliances responsible for the safe condition of the appliance and the safety of the appliance operator. **If in any doubt about electrical safety, contact a qualified electrician.**
- 1.1.3. Ensure the insulation on all cables and the product itself is safe before connecting to the mains power supply. See 1.1.1. & 1.1.2. above and use a Portable Appliance Tester (PAT).
- 1.1.4. Ensure that cables are always protected against short circuit and overload.
- 1.1.5. Regularly inspect power supply, leads, plugs for wear and damage and all electrical connections
- 1.1.6. to ensure that none is loose.
- 1.1.7. **Important:** Ensure the voltage marked on the product is the same as the electrical power supply to be used and check that supply is correctly fused, see fuse rating at right.
- 1.1.8. **DO NOT** pull or carry the powered appliance by its power supply lead.
- 1.1.9. **DO NOT** pull power plugs from sockets by the power cable.
- 1.1.10. **DO NOT** use worn or damaged leads, plugs or connections. Immediately replace or have repaired by a qualified electrician.
- 1.1.11. This product comes without a plug. **You must** contact a qualified electrician to ensure an adequate supply is available.

If fitting such a plug -

Ensure that the unit is correctly wired and earthed, as follows:

 - a) Connect the **GREEN/YELLOW** earth wire to the earth terminal 'E'.
 - b) Connect the **BROWN** live wire to live terminal 'L'.
 - c) Connect the **BLUE** neutral wire to the neutral terminal 'N'.
 - d) **After wiring, check there are no bare wires, that all wires have been correctly connected, that the cable outer insulation is clamped by the cable grip and that the grip is tight.**
- 1.1.12. **Cable extension reels.** When a cable extension reel is used it should be fully unwound before connection. A cable reel with an RCD fitted is recommended since any product which is plugged into the cable reel will be protected. The section of the cores of the cable is important. 2.5mm² section is a minimum, but to be absolutely sure that the capacity of the cable reel is suitable for this product and for others that may be used in the other output sockets, we recommend the use of 2.5mm² section cable.
- 1.2. **GENERAL SAFETY**
 - **WARNING! Ensure there is nobody in front of the lamp when it is switched on.**
 - ✓ Disconnect the panel dryer from the power supply before servicing, changing accessories, or performing any maintenance.
 - ✓ Ensure that the panel dryer is in good condition before use. If in any doubt do not use the unit and contact an electrician.
 - ✓ Familiarise yourself with the application and limitations of the panel dryer.
 - ✓ Check that lamp guards are in place, undamaged and firmly attached.
 - ✓ Keep tools and other items away from the panel dryer when it is in use.
 - ✓ Keep the work area clean and clear of unnecessary items.
 - ✓ Remember that the lamp panel will get hot, allow to cool after use.
 - ✓ Maintain the panel dryer in good condition. Use authorised agent for servicing.
 - ✓ Keep the dryer clean, but **DO NOT** use solvents.
 - ✓ Use only genuine parts and accessories. *Unauthorised parts and accessories may be dangerous and will invalidate your warranty.*
 - ✗ **DO NOT** use this product to perform a task for which it has not been designed.
 - ✗ **DO NOT** use the panel dryer outdoors, or in damp, or wet locations.

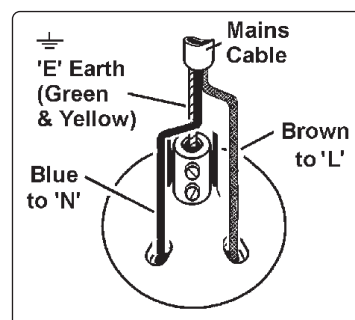

THIS PRODUCT REQUIRES A MINIMUM 16 AMP SUPPLY

- ✘ **DO NOT** operate within the vicinity of flammable liquids, gases or solids.
- ☐ **WARNING! Never use in explosive situations.**
- ✓ Keep children and unauthorised persons away from the work area.
- ✓ When not in use, store the panel dryer carefully in a safe, dry, childproof location.

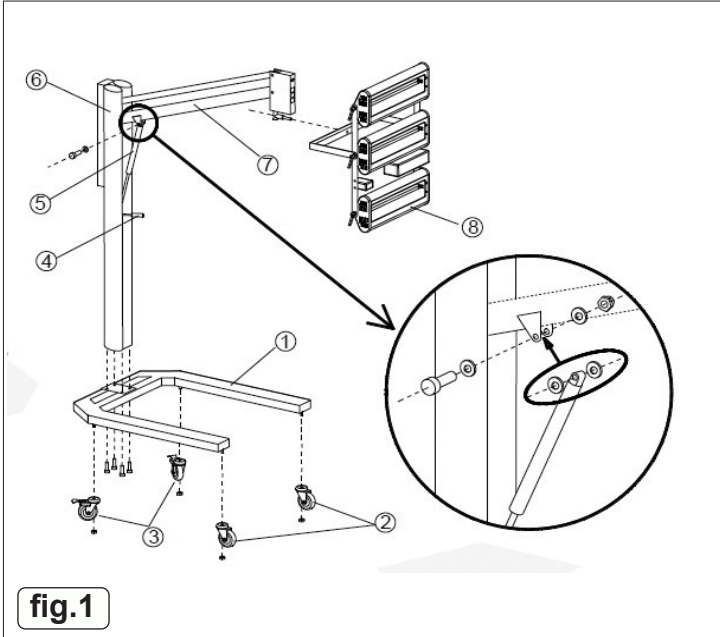

2. INTRODUCTION

Distance sensor shows optimal distance from the work piece. Memory function stores up to four frequently used settings. Lamps emit short wave infrared heat ideal for optimised drying of water based paints. Flexible lamp system allows each heater to be adjusted and locked in position around the contours of the vehicle, ensuring maximum area coverage. In built timer turns lamps off after a set time. Height adjustment is made using the locking gas strut, offering near weightless movement of the support arm. Ergonomic push buttons designed to be easier to use than analogue controls. Fitted with four castors wheels, two with brakes for maximum manoeuvrability and safe positioning.

3. SPECIFICATION

Model No:..... IR3000.V3
 Element power:3150W
 Number of elements..... 3 x 1050W
 Power cable length..... 3.7m
 Reflector Size:.....530mm x 140mm

4. INSTALLATION

4.1. BASE FRAME ASSEMBLY (fig.1)

- 4.1.1. Take out the pedestal (1) from package, install the castor wheels (3) with a brake at the rear side of the pedestal and the brake-less wheels (2) in the front of the pedestal.
- 4.1.2. Fix the post (6) on the pedestal (1), and mount the gas spring (5) onto the cross arm (7).

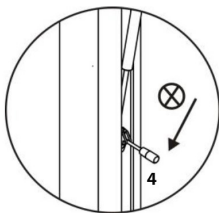

fig.2

NOTE: When installing, do not press the gas spring handle (Fig.2.4) on the post, otherwise it may cause injury due to the rapid lifting of the cross arm (Fig.1.7).

- 4.1.3. Install the lamp unit (8) directly in the screw in the cross arm (7).
- 4.1.4. Plug in wiring assemblies into control unit.

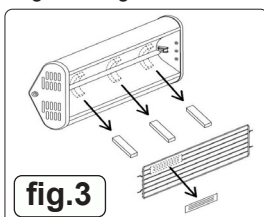

fig.3

NOTE: Remove the red plastic foam from the light tube and peel the sticker off the protective cover (fig.3).

5. OPERATION

1	Time duration window
2	Memory key
3	Light switches for lamp 3
4	Light switches for lamp 4
5	Light switches for lamp 5
6	Pre-heating time keys
7	Full baking time
8	Key for ultrasonic distance sensor
9	Pause / off key (press once to pause and twice to stop)
10	Start Key
11	Power switch

NOTE: If the machine is working or paused, keys 2, 6 & 7 will be deactivated and will be activated when the machine stops working.

5.1. POSITIONING AND ADJUSTING

- 5.1.1. Move the machine and adjust the distance between the lamp unit and the surface to be repaired (about 50cm).
- 5.1.2. Press the gas spring handle to adjust the height of the lamp unit to the surface to be repaired.
- 5.1.3. Adjust the lamp unit angle to allow it to be parallel to the surface to be repaired.
- 5.1.4. Press down the brake in the rear wheels to avoid any accidental movement of the machine.

5.1.5. BAKING TIMER CONTROL

- 5.1.6. Check power switch (Fig.4.11) is set to the off position and connect to the power supply.
- 5.1.7. Turn on the main switch 11.
- 5.1.8. Set the preheating time. The default value is 15 min. It will switch to full baking automatically after finishing pre heating. Please adjust key 6 to option if you do not need pre heating function.
- 5.1.9. The optimal distance is the one when the green LED lights on. Press the distance sensor key 8, and move the machine for better distancing as required, you can also shut down or ignore this function.
- 5.1.10. Select the keys 3/4/5 in order for the light units required to operate.
- 5.1.11. Press Key 10 and the lamp cassette will start working.
- 5.1.12. Press pause key 9 (press once) to pause the machine, then press the start key 10 to restart the lamp. If you want to shut down the lamp, just press key 9 twice.
- 5.1.13. There is a beep sound when it finishes its time.

5.2. MEMORY FUNCTION

- 5.2.1. The pre heating and full baking time can be adjusted based on the paint type for convenience, there are also four memory keys for adjusting time.
- 5.2.2. Press and hold one of the four memory keys for two seconds, the preheating and full baking time will be stored in this key.
- 5.2.3. When you need the stored setting in a key, just press the corresponding key.
- 5.2.4. When resetting the memory, just repeat Step (1) to store new settings, and the old setting will be deleted at the same time.

5.3. OPERATION OF THE ULTRASONIC DISTANCE LED LIGHT

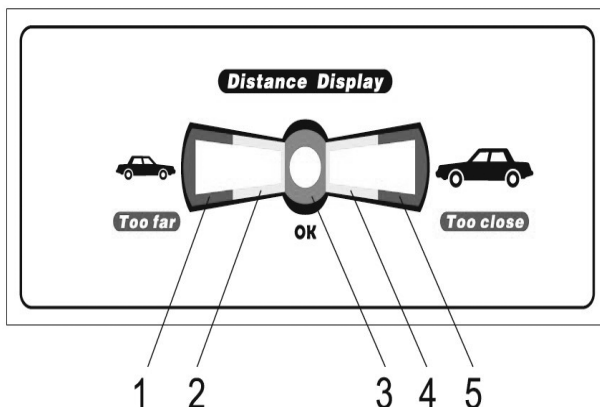

Position	LED Light Colour light on	Distance spacing
1	Red	Too far away distance.
2	Yellow	Bring closer to lamp unit.
3	Green	Correct distance.
4	Yellow	Bring closer to lamp unit.
5	Red	Too close to lamp unit.



fig.4

6. MAINTENANCE

- ❑ **WARNING:** Unplug Lamp unit from the electric power supply before performing maintenance or service
- 6.1. Remove all objects in front of the lamp tubes before starting.
- 6.2. Regular cleaning of tubes and reflector panel should be done by using a piece of soft cloth or cotton with alcohol (Note: cleaning must be conducted after the machine is disconnected with the power and cooled down). **DO NOT** operate the lamp unit until the alcohol has evaporated, otherwise it may lead to an explosion.
- 6.2.1. If any lamp tube fails to work after starting, it may result from the loosened outlet socket. In such case, just switch off the machine and insert the plug to the socket on the connective box.
- 6.3. REPLACEMENT OF LAMP EMITTER TUBE**
- 6.3.1. Check power switches are in the off position and is disconnected from the mains supply.
- 6.3.2. Take out the front protective net in front of the lamp emitter tube.
- 6.3.3. Loosen the screws on the side panel of the emitter and remove the side panel.
- 6.3.4. Release rear panel
- 6.3.5. Loosen the two leads in the lamp tube and remove the tube
- 6.3.6. Fix the new tube with same model number and wire the tube correctly.
- 6.3.7. Install the rear panel reflective panel and the side panel.
- 6.3.8. Use a piece of soft cloth or cotton to clean the reflective panel and the tube with alcohol.
- 6.3.9. Install the front protective grill..



ENVIRONMENT PROTECTION

Recycle unwanted materials instead of disposing of them as waste. All tools, accessories and packaging should be sorted, taken to a recycling centre and disposed of in a manner which is compatible with the environment. When the product becomes completely unserviceable and requires disposal, drain any fluids (if applicable) into approved containers and dispose of the product and fluids according to local regulations.



REGISTER YOUR PURCHASE HERE



WEEE REGULATIONS

Dispose of this product at the end of its working life in compliance with the EU Directive on Waste Electrical and Electronic Equipment (WEEE). When the product is no longer required, it must be disposed of in an environmentally protective way. Contact your local solid waste authority for recycling information.

Note: It is our policy to continually improve products and as such we reserve the right to alter data, specifications and component parts without prior notice.

Important: No Liability is accepted for incorrect use of this product.

Warranty: Guarantee is 12 months from purchase date, proof of which is required for any claim.

Sealey Group, Kempson Way, Suffolk Business Park, Bury St Edmunds, Suffolk. IP32 7AR



01284 757500



sales@sealey.co.uk



www.sealey.co.uk