



2100W INFRARED PANEL DRYER - SHORT WAVE

MODEL NO: IR2000S

Thank you for purchasing a Sealey product. Manufactured to a high standard, this product will, if used according to these instructions, and properly maintained, give you years of trouble free performance.

IMPORTANT: PLEASE READ THESE INSTRUCTIONS CAREFULLY. NOTE THE SAFE OPERATIONAL REQUIREMENTS, WARNINGS & CAUTIONS. USE THE PRODUCT CORRECTLY AND WITH CARE FOR THE PURPOSE FOR WHICH IT IS INTENDED. FAILURE TO DO SO MAY CAUSE DAMAGE AND/OR PERSONAL INJURY AND WILL INVALIDATE THE WARRANTY. KEEP THESE INSTRUCTIONS SAFE FOR FUTURE USE.



Refer to instruction manual



Warning: Electricity



Warning: Hot Surface



Indoor Use Only



Do Not Cover

1. SAFETY

1.1. ELECTRICAL SAFETY

- WARNING!** It is the user's responsibility to check the following:

Check all electrical equipment and appliances to ensure that they are safe before using. Inspect power supply leads, plugs and all electrical connections for wear and damage. Sealey recommend that an RCD (Residual Current Device) is used with all electrical products. You may obtain an RCD by contacting your local Sealey stockist.

If the product is used in the course of business duties, it must be maintained in a safe condition and routinely PAT (Portable Appliance Test) tested.

Electrical safety information: it is important that the following information is read and understood.

- 1.1.1. Ensure that the insulation on all cables and on the appliance is safe before connecting it to the power supply.
- 1.1.2. Regularly inspect power supply cables and plugs for wear or damage and check all connections to ensure that they are secure.
- 1.1.3. **Important:** Ensure that the voltage rating on the appliance suits the power supply to be used and that the plug is fitted with the correct fuse - see fuse rating in these instructions.
 - * **DO NOT** pull or carry the appliance by the power cable.
 - * **DO NOT** pull the plug from the socket by the cable.
 - * **DO NOT** use worn or damaged cables, plugs or connectors. Ensure that any faulty item is repaired or replaced immediately by a qualified electrician.
- 1.1.4. This product is fitted with a BS1363/A 3 pin plug.
 - If the cable or plug is damaged during use, switch the electricity supply and remove from use. Ensure that repairs are carried out by a qualified electrician.
 - Replace a damaged plug with a BS1363/A 3 pin plug. If in doubt contact a qualified electrician.
 - A) Connect the GREEN/YELLOW earth wire to the earth terminal 'E'.
 - B) Connect the BROWN live wire to the live terminal 'L'.
 - C) Connect the BLUE neutral wire to the neutral terminal 'N'.
 - Ensure that the cable outer sheath extends inside the cable restraint and that the restraint is tight. Sealey recommend that repairs are carried out by a qualified electrician.

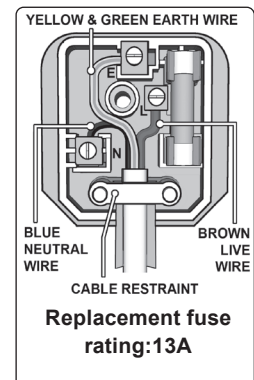

1.2. GENERAL SAFETY

- WARNING!** If a fuse blows, ensure it is replaced with a fuse of identical type and rating.
- WARNING!** Ensure there is nobody in front of the lamp when it is switched on.
- ✓ Disconnect the panel dryer from the power supply before servicing, changing accessories, or performing any maintenance.
- ✓ Ensure that the panel dryer is in good condition before use. If in any doubt do not use the unit and contact an electrician.
- ✓ When not in use, store the panel dryer carefully in a safe, dry, childproof location.
- ✓ Familiarise yourself with the application and limitations of the panel dryer.
- ✓ Check that lamp guards are in place, undamaged and firmly attached.
- ✓ Keep tools and other items away from the panel dryer when it is in use.
- ✓ Keep the work area clean and clear of unnecessary items.
- ✓ Keep children and unauthorised persons away from the work area.
- ✓ Remember that the lamp panel will get hot, allow to cool after use.
- ✓ Maintain the panel dryer in good condition. Use authorised agent for servicing.
- ✓ Keep the dryer clean, but **DO NOT** use solvents.
- ✓ Use only genuine parts and accessories. Unauthorised parts and accessories may be dangerous and will invalidate your warranty.
- * **DO NOT** use this product to perform a task for which it has not been designed.
- * **DO NOT** use the panel dryer outdoors, or in damp, or wet locations, and **DO NOT** operate within the vicinity of flammable liquids, gases or solids.

2. INTRODUCTION

Designed and developed to assist with any number of small drying processes. Ideal for spot repairs, engine drying, adhesive stripe removal, drying filler, drying primer or just preheating prior to spraying. Supplied with a sturdy 1500mm plated steel stand and a 3.7m power cable and 3-pin plug.

3. SPECIFICATION

Model No:.....IR2000S
Element Power:.....2100W
Fuse Rating:..... 13A
Number of elements:..... 2
Plug Type:.....3-Pin BS
Power Supply Cable Length:..... 3.7m
Reflector Size:..... 530mm x 140mm
Supply:..... 230V

4. ASSEMBLY

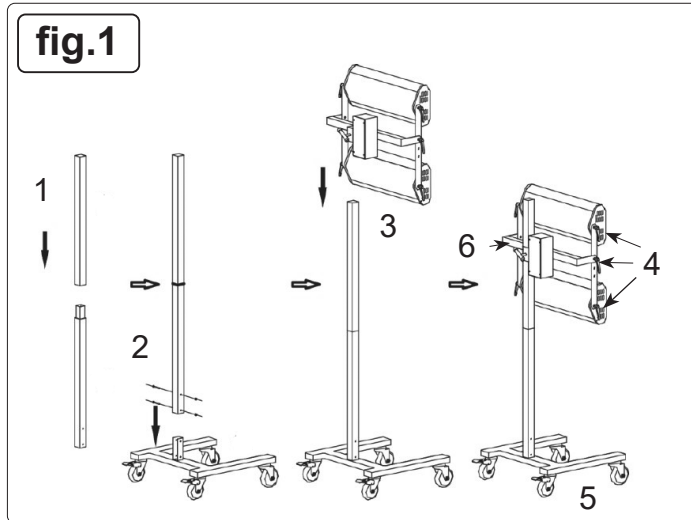

4.1. BASE FRAME ASSEMBLY (fig.1)

- 4.1.1. Take out the two parts of the post, peel off the sticker, then insert the upper section of the post into the lower section (Fig.1.1)
- 4.1.2. Take out the pedestal, insert the assembled post into the pedestal, (Fig.1.2) and tighten the screws.
- 4.1.3. Fix the locking hoop onto the post (Fig1.3), attach the lamp units in the front and then tighten the handles (Fig.1.4).
- 4.2. Install the castor wheels with a brake at the rear side of the pedestal and the brake-less castor wheels in the front of the pedestal. (Fig1.5)
- 4.2.1. Install the lamp units and screw in the cross arm (Fig1.6).

4.3. ASSEMBLE LAMPS (fig.2)

- 4.3.1. Remove the red plastic film and sponge from the emitter tube and peel the sticker off the protective cover. The lamps will need to be plugged into the control box individually.

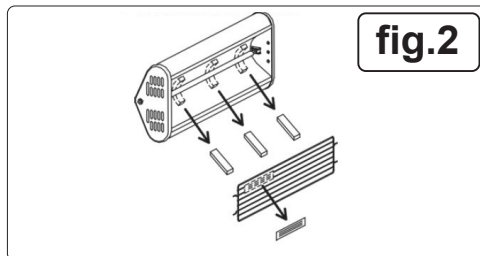

4.4. ADJUSTING LAMPS

- 4.4.1. When adjusting the height of lamp unit, use your left hand to support the U-shaped support and use your right hand to loosen the locking handle, and then move the lamp unit with your two hands supporting the two ends of the lamp unit. **DO NOT** try to adjust by using one hand this will avoid causing any damage to the tube caused by lamp unit falling.

5. OPERATION

5.1. CONTROL TIMER (fig.3)

- 5.1.1. Place the panel dryer in the required area and lock the castor wheels.
- 5.1.2. Turn the temperature to the required setting.
- 5.1.3. Switch on either switch A or B power switches or both depending on job requirement.
- 5.1.4. Now turn the baking timer control to the required time for the job. The switches on A and or B will light and commence to illuminate the lights selected.
- 5.1.5. When the time has expired the unit will automatically turn off. If longer time required just re-adjust the baking timer control and the job can be continued.

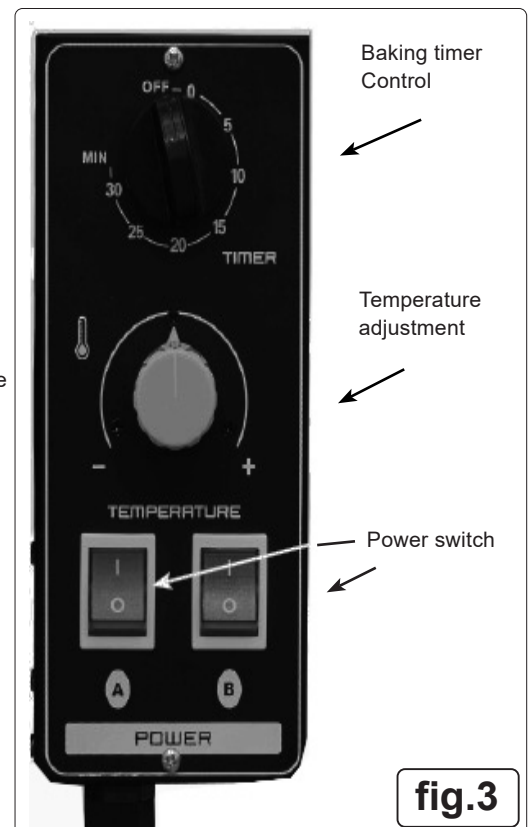

6. MAINTENANCE

- ❑ **WARNING!** Disconnect from the mains before carrying out any maintenance.
- ❑ **WARNING!** Never touch the element glass directly with fingers, only touch the ceramic ends or use a soft cloth, otherwise the tube may get damaged.

6.1. REPLACEMENT OF EMITTER TUBE

- 6.1.1. Check power switches are in the off position and is disconnected from the mains supply.
- 6.1.2. Take out the front protective grill in front of the emitter.
- 6.1.3. Loosen the screws on the side panel of the emitter and remove the side panel.
- 6.1.4. Release rear panel
- 6.1.5. Loosen the two leads in the lamp tube and remove the tube
- 6.1.6. Fix the new tube with same model number and wire the tube correctly.
- 6.1.7. Install the rear panel reflective panel and the side panel.
- 6.1.8. Use a piece of soft cloth or cotton to clean the reflective panel and the tube with alcohol.
- 6.1.9. Install the front protective grill.

7. TROUBLESHOOTING

- 7.1. Causes of defects on repaired surface and troubleshooting method.

DEFECT	CAUSE	TROUBLESHOOTING
Small pores on the baked paint surface.	Too near between the lamp cassette and the repaired surface.	Increase the distance.
	Insufficient Preheating time.	Increase the preheating time.
	Fast thinning agent included in the paint.	Use standard or slow thinning agent.
Dim paint.	Too far between the emitter and the repaired surface.	Make the machine closer.
	Insufficient baking.	Increase the baking time
	Too thick coating.	Thin the coating.
Stains.	Too long baking.	Shorten the baking.
	Too near distance.	Increase the distance.
Fuzzy edge.	The repair surface is too large.	Preheating for first time, and do not use preheating for second time.
Uneven baking.	The emitter is not as height as the repaired surface.	Adjust the emitter to allow it to be as height as the repaired surface.

NOTE: For optimal baking performance, we recommend that users should work out the suitable operating procedures, baking time and distance according to the local natural conditions, working environment and the types of paints.



ENVIRONMENT PROTECTION

Recycle unwanted materials instead of disposing of them as waste. All tools, accessories and packaging should be sorted, taken to a recycling centre and disposed of in a manner which is compatible with the environment. When the product becomes completely unserviceable and requires disposal, drain any fluids (if applicable) into approved containers and dispose of the product and fluids according to local regulations.



WEEE REGULATIONS

Dispose of this product at the end of its working life in compliance with the EU Directive on Waste Electrical and Electronic Equipment (WEEE). When the product is no longer required, it must be disposed of in an environmentally protective way. Contact your local solid waste authority for recycling information.

Note: It is our policy to continually improve products and as such we reserve the right to alter data, specifications and component parts without prior notice. Please note that other versions of this product are available. If you require documentation for alternative versions, please email or call our technical team on technical@sealey.co.uk or 01284 757505.

Important: No Liability is accepted for incorrect use of this product.

Warranty: Guarantee is 12 months from purchase date, proof of which is required for any claim.

Sealey Group, Kempson Way, Suffolk Business Park, Bury St Edmunds, Suffolk. IP32 7AR

01284 757500

sales@sealey.co.uk

www.sealey.co.uk