



20.5KW INFRARED PARAFFIN/KEROSENE/ DIESEL HEATER

MODEL NO: **IR20.V5**

Thank you for purchasing a Sealey product. Manufactured to a high standard, this product will, if used according to these instructions, and properly maintained, give you years of trouble free performance.

IMPORTANT: PLEASE READ THESE INSTRUCTIONS CAREFULLY. NOTE THE SAFE OPERATIONAL REQUIREMENTS, WARNINGS & CAUTIONS. USE THE PRODUCT CORRECTLY AND WITH CARE FOR THE PURPOSE FOR WHICH IT IS INTENDED. FAILURE TO DO SO MAY CAUSE DAMAGE AND/OR PERSONAL INJURY AND WILL INVALIDATE THE WARRANTY. KEEP THESE INSTRUCTIONS SAFE FOR FUTURE USE.



Refer to instructions



Wear protective gloves



Electrical shock hazard



Hot surfaces



Do not cover



Keep in dry area protect from rain

This product is not suitable for primary heating purposes.

1. SAFETY

1.1. ELECTRICAL SAFETY

- WARNING!** It is the user's responsibility to check the following:
Check all electrical equipment and appliances to ensure that they are safe before using. Inspect power supply leads, plugs and all electrical connections for wear and damage. Sealey recommend that an RCD (Residual Current Device) is used with all electrical products. You may obtain an RCD by contacting your local Sealey stockist.
If used in the course of business duties, it must be maintained in a safe condition and routinely PAT (Portable Appliance Test) tested. Electrical safety information, it is important that the following information is read and understood.
- ✓ Ensure that the insulation on all cables and on the appliance is safe before connecting it to the power supply.
- ✓ Regularly inspect power supply cables and plugs for wear or damage and check all connections to ensure that they are secure.
- ✓ Ensure that the voltage rating on the appliance suits the power supply to be used and that the plug is fitted with the correct fuse - see fuse rating in these instructions.
- ✗ **DO NOT** pull or carry the appliance by the power cable.
- ✗ **DO NOT** pull the plug from the socket by the cable.
- ✗ **DO NOT** use worn or damaged cables, plugs or connectors. Ensure that any faulty item is repaired or replaced immediately by a qualified electrician.
- ✓ This product is fitted with a BS1363/A 13 Amp 3 pin plug.
If the cable or plug is damaged during use, switch the electricity supply and remove from use.
Ensure that repairs are carried out by a qualified electrician.
Replace a damaged plug with a BS1363/A 13 Amp 3 pin plug. If in doubt contact a qualified electrician.
 - a) Connect the GREEN/YELLOW earth wire to the earth terminal 'E'.
 - b) Connect the BROWN live wire to the live terminal 'L'.
 - c) Connect the BLUE neutral wire to the neutral terminal 'N'.Ensure that the cable outer sheath extends inside the cable restraint and that the restraint is tight.
Sealey recommend that repairs are carried out by a qualified electrician.

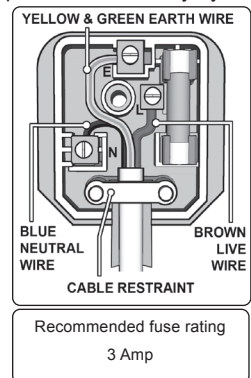

1.2. GENERAL SAFETY

- ▲ **DANGER!** Risk of carbon monoxide poisoning. Failure to provide proper ventilation could result in serious illness or death.
- ✓ Check that the heater is in sound condition and good working order. Take immediate action to repair or replace damaged parts.
- ✓ Use recommended parts only. Unauthorised parts may be dangerous and will invalidate the warranty.
- ✓ Only use paraffin, diesel or kerosene to fuel this heater, in accordance with instructions contained in this manual.
- ✓ Locate heater on a level and stable surface.
- WARNING!** Only use heater in well ventilated areas. Ensure continuous ventilation is provided to the heater operating area via windows and doors etc. If people are not required to be present in the heated area, the volume of air to be heated (m³)/heat output (kW) ratio must be at least 10:1 and people must be advised not to remain in the heated area for prolonged periods. If people are required to be present in the heated area, the volume of air to be heated (m³)/heat output (kW) ratio must be at least 30:1. Ventilation must be to the outside of the premises in which the heater is to be operated. The total open area (m²) must be at least 0.003 times the total heat output (kW). The volume concentration of oxygen (O₂) in the heated room, must always remain above 17%.
- WARNING! DO NOT** use the heater near flammable material, liquids, solids, gases or compressed gas cylinders etc.
- ✗ **DO NOT** stand or place any object less than 3m from the heater output and keep the heater a minimum of 2m from any walls or objects.
- ✗ **DO NOT** use the heater in closed rooms, living areas, basements or below ground level.
- ✗ **DO NOT** allow untrained persons to operate the heater and **DO NOT** operate the heater without the safety guard.
- ✗ **DO NOT** move or handle the heater when hot, without wearing protective gloves. Never move the heater whilst it is operating.
- ✗ **DO NOT** leave the heater unattended for prolonged periods of time when in use. Switch the heater off and unplug from the mains before leaving work area.
- ✗ **DO NOT** fill the fuel tank whilst the heater is running or still hot. **DO NOT** over-fill the fuel container. Wipe up any spilled fuel immediately.

- ✗ **DO NOT** obstruct the air inlet (rear) and air outlet (front) of the heater and **DO NOT** use duct work in front or at the rear of the heater.
 - ✗ **DO NOT** allow children or animals near the heater when in use, or whilst still hot.
 - ☐ **WARNING! RISK OF ELECTRIC SHOCK. DO NOT** expose the heater to water spray, rain, dripping water or wind.
 - ✗ **DO NOT** operate the heater when you are tired or under the influence of alcohol, drugs or intoxicating medication.
 - ✗ **DO NOT** touch the heater outlet or cone when in use, or for a period of time after it's switched off, as these are VERY hot and will take time to cool down.
 - ✗ **DO NOT** switch the heater off by disconnecting it from the mains. **ALWAYS** set the switch on the burner to the 'OFF' position and allow the cooling cycle to finish, before disconnecting from the mains.
 - ✗ **DO NOT** use an external fuel tank. Only use the tank that is fitted to the heater, and only fill it when the heater has cooled down.
 - ✓ Ensure that the heater is correctly turned off.
 - ✓ When not in use for an extended period, store in a safe, dry area, out of reach of children.
- NOTE:** This appliance is not intended for use by persons (including children) with reduced physical, sensory or mental capabilities or lack of experience and knowledge, unless they have been given supervision or instruction concerning the use of the appliance by a person responsible for their safety.
- Children should be supervised to ensure that they do not play with the appliance.

2. INTRODUCTION

Versatile multi-fuel heater designed to run on paraffin, kerosene or diesel. Clean burning unit suitable for well-ventilated applications. 15L Tank allows approximately 8hrs running time, making this unit extremely economical. Safety features include automatic overheat safety shut-off and quiet operation. Optional trolley available for easy manoeuvrability, Model No. IR20T.

3. SPECIFICATION

Model No..... **IR20.V5**
 Fuel Tank: 15L
 Fuel: Paraffin/Kerosene/Diesel
 Heated Area: 14,000ft³(396m³)
 Output: 70,000Btu/hr(20.5kW)
 Run Time per Filling (Maximum): 8hr
 Supply: 230V - 3A

4. ASSEMBLY

- 4.1. Unpack the heater and check contents. Should there be any damaged or missing parts contact your Sealey stockist immediately.
- 4.2. Attach handle by lining up the holes in the handle with the holes in the upper shell of the heater (fig.1).
- 4.3. Insert screws and tighten.
- 4.4. Remove heater and packaging material from the carton.

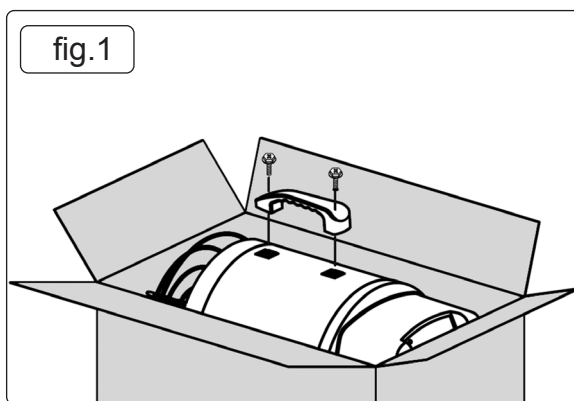
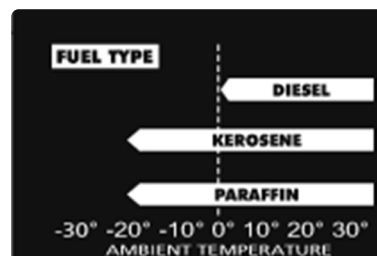
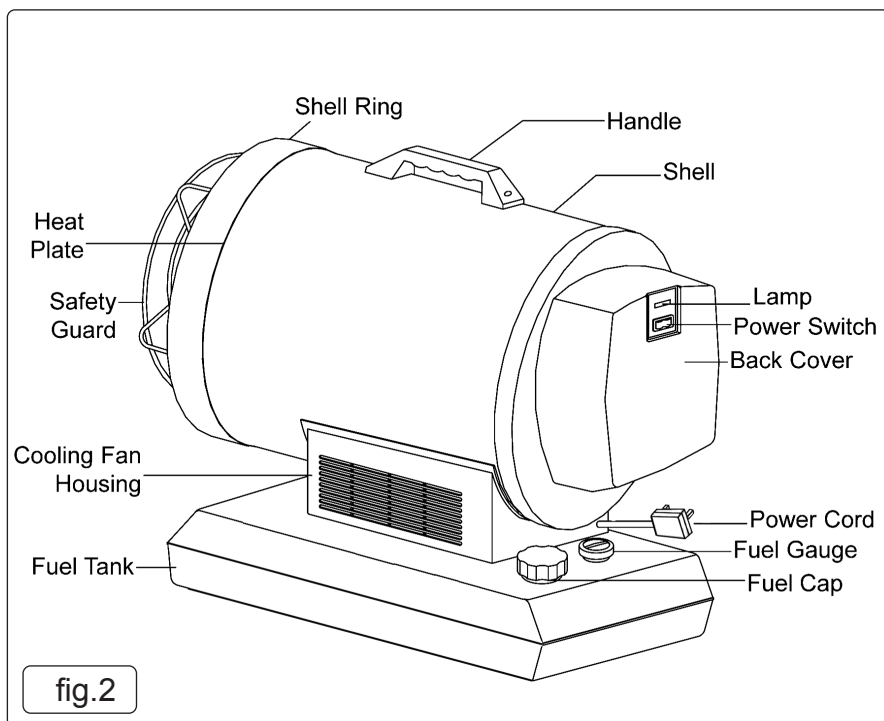

fig.2A



Although our heaters operate with diesel fuel, when the temperatures are below 0°C, diesel additives are required to maintain the diesel's viscosity. Typically diesel can cloud in freezing conditions and will start to gel. You will need additives for your fuel in these conditions. Kerosene/Paraffin does not start to gel until the ambient temperature is around (-40°C).

5. OPERATION

- 5.1. **FUELLING THE HEATER see fig.2A above right**
 - 5.1.1. This appliance is designed to operate safely at a minimum ambient temperature of -20°C.
 - 5.1.2. For optimal performance of this heater, use paraffin. Paraffin has been refined to virtually eliminate contaminants, such as sulphur, which can cause a rotten egg odor during the operation of the heater. Using diesel fuel can cause excess soot production. **DO NOT** use bio-diesel as this fuel will damage your heater's seals and filter.
 - ✗ **DO NOT** use fuel such as, benzene, alcohol, white glass, camp stove fuel, paint thinners, or other oil compounds in this heater. these are volatile fuels that can cause a fire or explosion.
 - ✗ **DO NOT** store paraffin in the living space. Paraffin should be stored in a well ventilated area outside the living area.

- × **DO NOT** store paraffin in direct sunlight or near a source of heat.
- × **DO NOT** use paraffin that has been stored from one season to the next. Paraffin deteriorates over time, old paraffin will not burn properly in this heater.

5.2. VENTILATION

5.2.1. Risk of indoor air pollution and carbon monoxide poisoning. Use heater only in well ventilated areas.

5.2.2. Always provide a fresh air opening in the heated space of at least 2,800 cm² (3 sq. ft) for each 29 kw / hr. of heater output.

5.2.3. Provide a larger opening if more heaters are being used.

5.2.4. Minimum Ventilation Opening Needed for this heater is 64cm².

5.3. STARTING THE HEATER (IGNITION)

NOTE: If air has entered the fuel line; possible when new, when left standing for a long period or when the tank level has fallen too low, priming may be necessary. It is preferable to start the heater outdoors for the first time, to allow any oils left over from the manufacturing process and transporting to be burnt off in a safe environment. Run it for 10 minutes on this first burn.

5.3.1. Fill the tank with paraffin or other approved fuel until needle on fuel gauge points to "F". Replace fuel cap and tighten firmly.

5.3.2. Connect the heater to a power source. You must use extension cable that is at least 1.8 meters long and is a minimum of 14 AWG rating.

5.3.3. Push the power switch to the "ON" position. The power indicator lamp will light and heater will ignite fig.3.

NOTE: On first ignition or after refueling you may hear a grinding sound just before ignition. This is the fuel pump removing the air from the fuel line. Your heater will start up within seconds. If it does not start repeat start-up procedures with fuel gauge reading at least 1/2 tank.

NOTE: The electrical components of these heaters are protected by a fuse mounted in the PC board. If the heater fails to ignite check this fuse first and replace if necessary. Also check the power source to be sure the proper voltage is being provided to the heater.

5.4. STOPPING THE HEATER

5.4.1. Turn the power switch to the "OFF" position. Combustion will stop and the Cooling Cycle will begin. approx. 7 mins.

5.4.2. When the Cooling Cycle is complete the fan will stop running and it will be safe to unplug the heater.

NOTE: Unplugging the heater before the Cooling Cycle has been completed may cause overheating, possible damage to the heater and heat plate.

5.5. RESTARTING THE HEATER

5.5.1. Wait ten seconds after Cooling Cycle has been completed.

5.5.2. Follow all start-up procedures above.

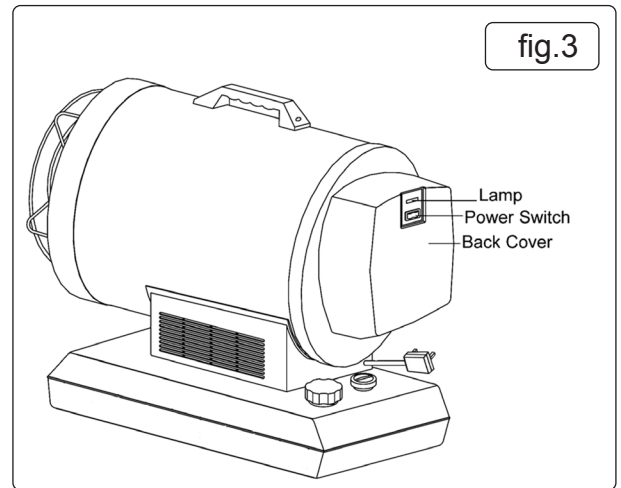

6. MAINTENANCE

- ❑ **WARNING!** Unplug unit from mains power supply ensure heater is cold before opening or servicing heater.
- ❑ **WARNING! DO NOT** tamper with the unit, have an experienced serviceman make any necessary adjustment or repairs.

6.1. LONG TERM STORAGE

6.1.1. Unscrew the fuel cap.

6.1.2. Using an approved siphon, remove the Paraffin or diesel.

6.1.3. Using a small amount of Paraffin or diesel, rinse and swirl the fuel inside the fuel tank.

6.1.4. Empty the tank completely.

NOTE: never mix water with fuel, it will cause rust inside the tank.

IMPORTANT: Never store leftover Paraffin between seasons, using old fuel can damage heater.

6.1.5. Store Heater in a dry, well ventilated area. Be sure that the storage area is free of dust and corrosive vapours. Repack the heater in the original packaging and keep user's manual in an easily accessible place.

6.2. FUEL / FUEL TANK

6.2.1. Flush tank every 200 hours of operation or as needed. **DO NOT** flush with water, use fresh paraffin only.

6.3. SPARK PLUG

6.3.1. Clean and re-gap every 600 hours of operation or replace as needed. After removing the spark plug, clean the terminals with a wire brush, re-gap the terminals to 0.140" (3.5mm) fig.4.

6.4. FAN BLADES

6.4.1. The fan blades should be cleaned at least once per heating season, depending on conditions. remove all accumulated dust and dirt with a burst of condensed air fig.5.

6.5. NOZZLES

6.5.1. Nozzles should be cleaned or replaced at least once per heating season. Contaminated fuel could make this necessary immediately.

6.5.2. To clean dirt from nozzle, blow compressed air through nozzle front. it may be necessary to soak nozzle in clean paraffin or diesel to help loosen any particles fig.6.

6.6. PHOTOCCELL

6.6.1. The photocell should be cleaned at least once per heating season or more depending on conditions, use a cotton swab and water or, alcohol to clean the lens of the photocell. Be certain to reinstall the photocell in proper position as shown in fig.7.

6.7. FILTERS

6.7.1. The fuel filter and oil filter should be cleaned at least twice per heating season by rinsing it in clean paraffin or diesel. Contaminated or old fuel could make cleaning necessary immediately fig.8.

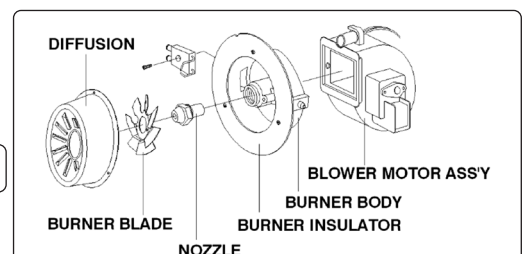
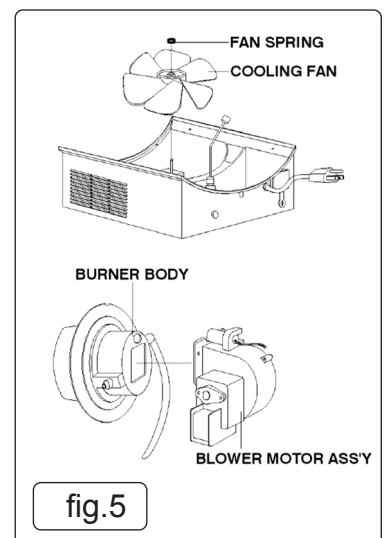
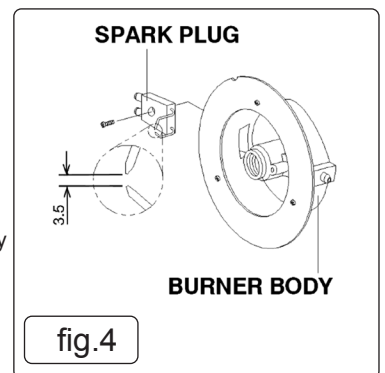

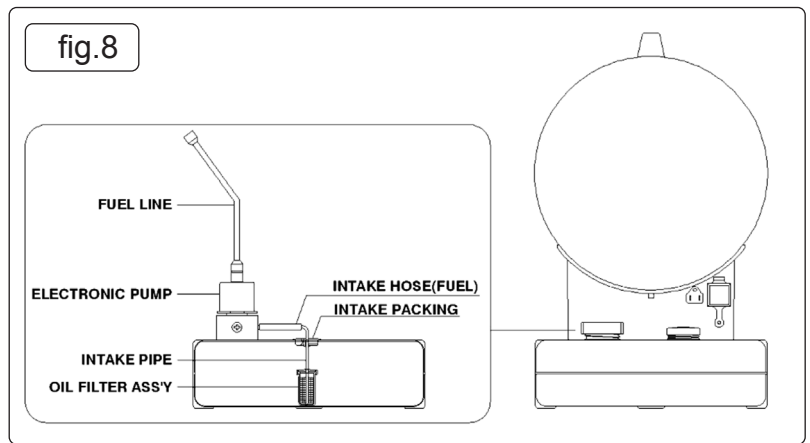
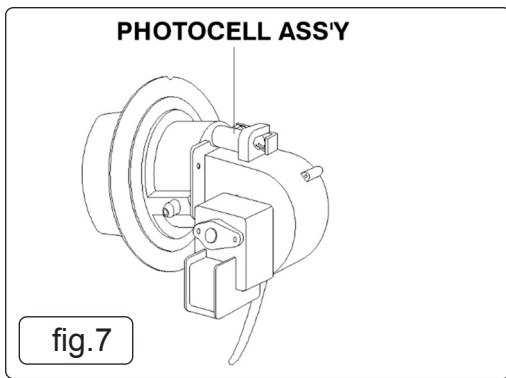

7. TROUBLESHOOTING

Problem	Possible Cause	Solution
Heater fires, but shuts down after a short period of time.	1. Dirty Fuel Filter	1. Clean/replace Fuel Filter
	2. Nozzle Dirty	2. Clean/replace Nozzle
	3. Photocell Dirty	3. Clean/replace Photocell
	4. Photocell not installed properly	4. Adjust Photocell position
	5. Photocell Defective	5. Replace Photocell
	6. Improper electrical connection between Circuit Board and Photocell	6. Check wiring connections
	7. Cooling Fan is obstructed	7. Check to be sure cooling fan is not obstructed
Heater will not operate, or motor runs for short time.	1. No paraffin/ diesel in fuel tank	1. Fill tank with fresh paraffin/ diesel
	2. Corroded Spark Plug or incorrect plug gap	2. Clean/replace Spark Plug
	3. Dirty Fuel Filter	3. Clean/replace Fuel Filter
	4. Dirty Nozzle	4. Clean/replace Nozzle
	5. Moisture in Fuel/Fuel Tank	5. Rinse out fuel tank with clean fresh paraffin/ diesel
	6. Improper electrical connection between Transformer and Circuit Board	6. Inspect all electrical connections
	7. Transformer Wires not connected to Spark Plug	7. Re-attach Transformer wires to Spark Plug
	8. Defective Transformer	8. Replace Transformer
Fan does not operate when heater is plugged in and Operating Switch is in the "ON" position.	1. Broken electrical connection between Circuit Board and motor	1. Inspect all electrical connections on Wiring Diagrams
	2. Not enough amps available to power heater	2. Use a new extension cord or try another electrical socket
Heater makes grinding noise.	1. Air in fuel pump	1. Sound will stop after 3 seconds. If grinding sound continues, add fuel to tank
Heater does not turn on and the lamp is not lit.	1. Temperature limit sensor has overheated	1. Push Operating Switch to "OFF" and allow heater to cool for 5 minutes. Push Operating Switch back to "ON"
	2. No electrical power	2. Check power cord and extension cord to insure of proper connection. Test power supply
	3. Fuse break down	3. Check/replace Fuse
	4. Improper electrical connection between Temperature Limit Sensor and Circuit Board	4. Inspect all electrical connections
Poor combustion and / or soot production.	1. Pump Pressure	1. Be sure pump pressure is adjusted correctly
	2. Poor fuel quality	2. Be sure paraffin/ diesel is not old or contaminated



WEEE REGULATIONS

Dispose of this product at the end of its working life in compliance with the EU Directive on Waste Electrical and Electronic Equipment (WEEE). When the product is no longer required, it must be disposed of in an environmentally protective way. Contact your local solid waste authority for recycling information.



ENVIRONMENT PROTECTION

Recycle unwanted materials instead of disposing of them as waste. All tools, accessories and packaging should be sorted, taken to a recycling centre and disposed of in a manner which is compatible with the environment. When the product becomes completely unserviceable and requires disposal, drain any fluids (if applicable) into approved containers and dispose of the product and fluids according to local regulations.

Note: It is our policy to continually improve products and as such we reserve the right to alter data, specifications and component parts without prior notice. Please note that other versions of this product are available. If you require documentation for alternative versions, please email or call our technical team on technical@sealey.co.uk or 01284 757505.

Important: No Liability is accepted for incorrect use of this product.

Warranty: Guarantee is 12 months from purchase date, proof of which is required for any claim.

Sealey Group, Kempson Way, Suffolk Business Park, Bury St Edmunds, Suffolk. IP32 7AR



01284 757500



01284 703534



sales@sealey.co.uk



www.sealey.co.uk



Information requirements for gaseous/liquid fuel local space heaters

Model identifier(s): IR20.V5										
Indirect heating functionality: Yes No <input checked="" type="checkbox"/>										
Direct heat output: 20.5 (kW)				Indirect heat output: N/A (kW)						
Fuel						Space heating emissions NO _x nitrogen oxides				
Select fuel type:	Gaseous	Liquid <input checked="" type="checkbox"/>	Specify: Diesel			126.94 [mg/kWh _{input}] (GCV)				
Item	Symbol	Value	Unit	Item	Symbol	Value	Unit			
Heat output				Useful efficiency (NCV)						
Nominal heat output	P_{nom}	19.9	kW	Useful efficiency at nominal heat output	$\eta_{th,nom}$	90.9	%			
Minimum heat output (indicative)*	P_{min}	N/A	kW	Useful efficiency at minimum heat output (indicative)*	$\eta_{th,min}$	N/A	%			
Auxiliary electricity consumption				Type of heat output/room temperature control (select one)						
At nominal heat output	$e_{l,max}$	0.087	kW	Single stage heat output, no room temperature control	Yes	No <input checked="" type="checkbox"/>				
At minimum heat output	$e_{l,min}$	N/A	kW	Two or more manual stages, no room temperature control	Yes	No <input checked="" type="checkbox"/>				
In standby mode	$e_{l,SB}$	N/A	kW	With mechanical thermostat room temperature control	Yes	No <input checked="" type="checkbox"/>				
* Enter figure or NA				With electronic room temperature control	Yes	No <input checked="" type="checkbox"/>				
				With electronic room temperature control plus day timer	Yes	No <input checked="" type="checkbox"/>				
				With electronic room temperature control plus week timer	Yes	No <input checked="" type="checkbox"/>				
				Other control options (multiple selections possible)						
				Room temperature control, with presence detection	Yes	No <input checked="" type="checkbox"/>				
				Room temperature control, with open window detection	Yes	No <input checked="" type="checkbox"/>				
				With distance control option	Yes	No <input checked="" type="checkbox"/>				
				With adaptive start control	Yes	No <input checked="" type="checkbox"/>				
Permanent pilot flame power requirement				With working time limitation	Yes	No <input checked="" type="checkbox"/>				
Pilot flame power required (if applicable)*	P_{pilot}	N/A	kW	With black bulb sensor	Yes	No <input checked="" type="checkbox"/>				
The seasonal space heating energy efficiency η_s										
Item	Symbol	Value	Unit							
The seasonal space heating Energy efficiency in active mode	$\eta_{s,on}$	100	%							
The seasonal space heating energy efficiency η_s	η_s	88.9	%							
Energy efficiency classes				A						
Contact details: Sealey Group, Kempson Way, Suffolk Business Park, Bury St Edmunds, Suffolk, IP32 7AR. www.sealey.co.uk										
v1						ERP Table 1				