

INFRARED PARAFFIN/DIESEL HEATER 18KW 230V

Thank you for purchasing a Sealey product. Manufactured to a high standard this product will, if used according to these instructions and properly maintained, give you years of trouble free performance.



IMPORTANT: PLEASE READ THESE INSTRUCTIONS CAREFULLY. NOTE THE SAFE OPERATIONAL REQUIREMENTS, WARNINGS AND CAUTIONS. USE THE PRODUCT CORRECTLY AND WITH CARE FOR THE PURPOSE FOR WHICH IT IS INTENDED. FAILURE TO DO SO MAY CAUSE DAMAGE AND/OR PERSONAL INJURY AND WILL INVALIDATE THE WARRANTY. PLEASE KEEP INSTRUCTIONS SAFE FOR FUTURE USE.

1. SAFETY INSTRUCTIONS

1.1. ELECTRICAL SAFETY

WARNING! It is the responsibility of the owner and the operator to read, understand and comply with the following:

You must check all electrical products, before use, to ensure that they are safe. You must inspect power cables, plugs, sockets and any other connectors for wear or damage. You must ensure that the risk of electric shock is minimised by the installation of appropriate safety devices. A Residual Current Circuit Breaker (RCCB) should be incorporated in the main distribution board. We also recommend that a Residual Current Device (RCD) is used. It is particularly important to use an RCD with portable products that are plugged into a supply which is not protected by an RCCB. If in any doubt consult a qualified electrician. You may obtain a Residual Current Device by contacting your Sealey dealer.

You must also read and understand the following instructions concerning electrical safety.

1.1.1. The **Electricity at Work Act 1989** requires all portable electrical appliances, if used on business premises, to be tested by a qualified electrician, using a Portable Appliance Tester (PAT), at least once a year.

1.1.2. The **Health & Safety at Work Act 1974** makes owners of electrical appliances responsible for the safe condition of those appliances and the safety of the appliance operators. **If in any doubt about electrical safety, contact a qualified electrician.**

1.1.3. Ensure that the insulation on all cables and on the appliance is safe before connecting it to the power supply. See 1.1.1. and 1.1.2. and use a Portable Appliance Tester.

1.1.4. Ensure that cables are always protected against short circuit and overload.

1.1.5. Regularly inspect power supply cables and plugs for wear or damage and check all connections to ensure that none are loose.

1.1.6. **Important:** Ensure that the voltage marked on the appliance matches the power supply to be used and that the plug is fitted with the correct fuse - see fuse rating at right.

1.1.7. **DO NOT** pull or carry the appliance by the power cable.

1.1.8. **DO NOT** pull the plug from the socket by the cable.

1.1.9. **DO NOT** use worn or damaged cables, plugs or connectors. Immediately have any faulty item repaired or replaced by a qualified electrician. When an ASTA/BS approved UK 3 pin plug is damaged, cut the cable just above the plug and **dispose of the plug safely**. Fit a new plug according to the following instructions (UK only).

a) Connect the **GREEN/YELLOW earth wire to the earth terminal 'E'**.

b) Connect the **BROWN live wire to the live terminal 'L'**.

c) Connect the **BLUE neutral wire to the neutral terminal 'N'**.

d) **After wiring, check that there are no bare wires, that all wires have been correctly connected, that the cable outer insulation extends beyond the cable restraint and that the restraint is tight.**

Double insulated products, which are always marked with this symbol , are fitted with live (brown) and neutral (blue) wires only.

To rewire, connect the wires as indicated above - **DO NOT** connect either wire to the earth terminal.

1.1.10. If an extension reel is used it should be fully unwound before connection. A reel with an RCD fitted is preferred since any appliance plugged into it will be protected. The cable core section is important and should be at least 1.5mm², but to be absolutely sure that the capacity of the reel is suitable for this product and for others which may be used in the other output sockets, we recommend the use of 2.5mm² section cable.

1.2. GENERAL SAFETY

DANGER! Risk of carbon monoxide poisoning. Failure to provide proper ventilation could result in serious illness or death.

✓ Check that the heater is in sound condition and good working order. *Take immediate action to repair or replace damaged parts.*

✓ Use recommended parts only. *Unapproved parts may be dangerous and will invalidate the warranty.*

✓ Only use paraffin or diesel to fuel your heater, in accordance with instructions contained in this manual.

WARNING! Only use heater in well ventilated areas. Ensure continuous ventilation from outside of the building is provided to the heater operating area.

✓ Keep the front of the heater a minimum of 2.4m (8ft) metres from any combustible materials (i.e. wooden items, cloth, plastics, paper, etc).

✓ Only operate on a level and stable surface.

WARNING! DO NOT use the heater near flammable material, liquids, solids, gases or compressed gas cylinders.

DO NOT use the heater in closed rooms, living areas, basements or below ground level.

DO NOT allow untrained persons to operate the heater and **DO NOT** operate the heater without the cover.

DO NOT move or handle the heater when hot.

DO NOT leave the heater unattended when in use. Switch the heater off and unplug from the mains before leaving work area.

DO NOT fill the fuel tank whilst the heater is running or still hot.

DO NOT over-fill the fuel container. Wipe up any spilt fuel immediately.

DO NOT obstruct the air inlet (rear) and air outlet (front) of the heater.

DO NOT use duct work in front or at the rear of the heater.

DO NOT allow children or animals near the heater when in use, or while hot.

WARNING! RISK OF ELECTRIC SHOCK. DO NOT expose the heater to water spray, rain, dripping water or wind.

DO NOT operate the heater when you are tired or under the influence of alcohol, drugs or intoxicating medication.

DO NOT touch the heater outlet or dome when first switched off as these are very hot and will take time to cool.

✓ Ensure that the heater is correctly turned off when not in use and store in a safe, dry area, out of reach of children.

DO NOT unplug the heater to switch it off. Use the ON/OFF switch.

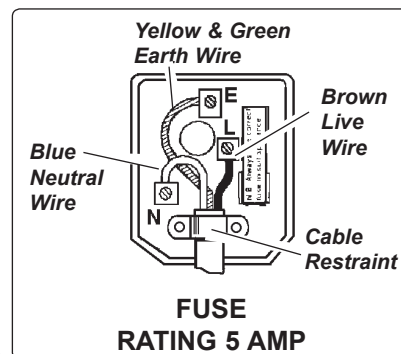

2. INTRODUCTION & SPECIFICATIONS

Infrared heater suitable for well ventilated indoor or outdoor applications. Clean burning unit operates on paraffin or diesel.

Unit develops 60,000 Btu/hr.

11ltr tank which will run for approximately 6.5hrs making this unit extremely economical. Fitted with a safety cutout.

Model	IR18
Rating BTU/hr/kW	60,000/18kW
Fuel	Paraffin/Diesel
Running Time Per Filling (Approx)	6.5Hr
Fuel Tank Capacity (Litres)	11
Voltage/Hz	230/50
Amps	5
Phase	Single
Power Cable (m)	2.1
Size (cm)	54 x 30.5 x 53.5
Net Weight (Kg)	14
Heated Area	425mtr ³
Min. clearance from Combustables	Top 1.2mtr Sides 1.2mtr Front 2.4mtr



3. ASSEMBLY

Unpack the heater and check contents. Should there be any damaged or missing parts contact your Sealey dealer immediately.

- 3.1. Attach handle by lining up the holes in the handle with the holes in the upper shell of the heater (Fig.1).
- 3.2. Insert screws and tighten.
- 3.3. Remove heater and packaging material from the carton.

Note! Retain the box and packaging material for future storage.

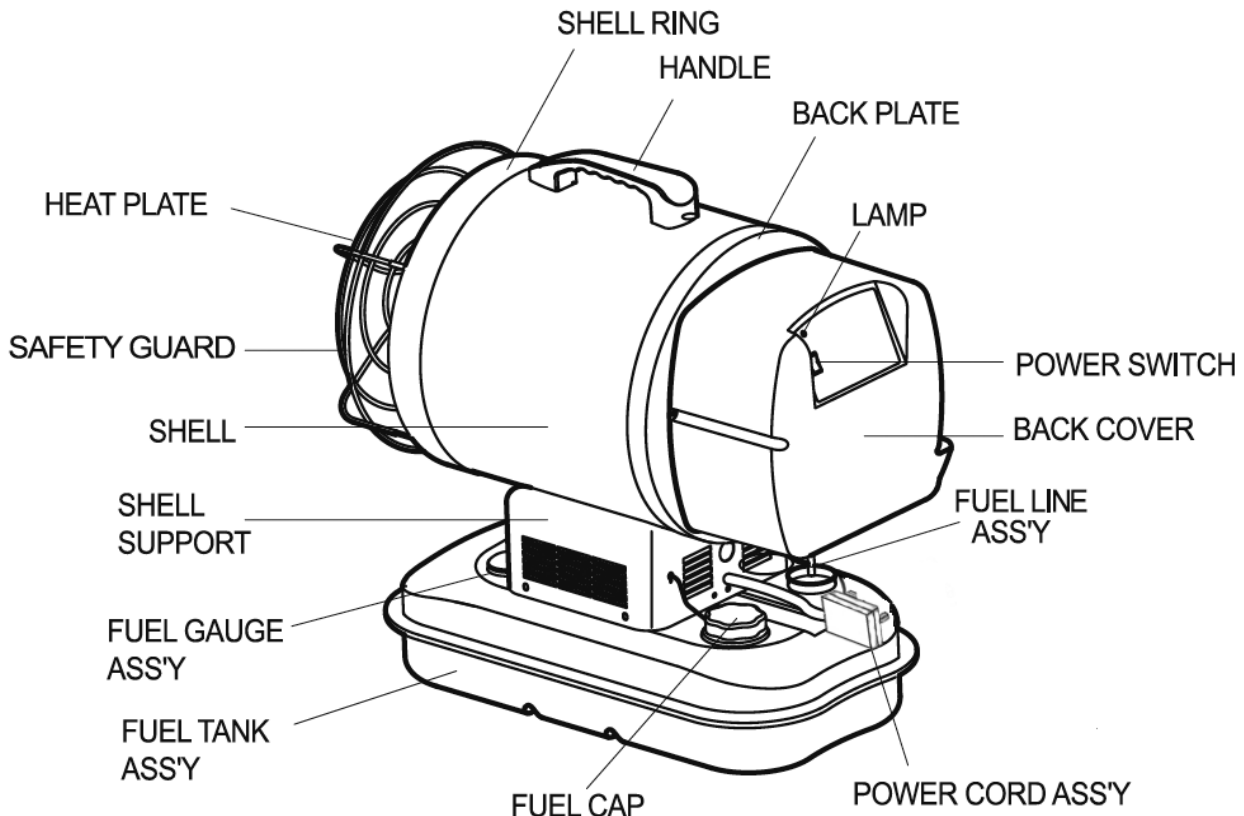
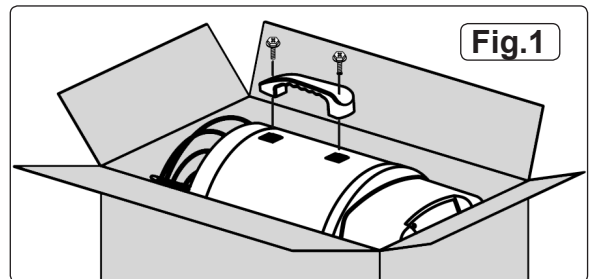

4. OPERATING CONDITIONS

4.1. Principles Of Heat Generation

4.1.1. Fuel System

This heater is equipped with an air pump that is powered by the electric motor. The pump forces air through the air line connected to the fuel tank, drawing fuel to the nozzle in the burner head. Air also passes through the nozzle where it mixes with the fuel and is sprayed into the combustion chamber in a fine mist.

4.1.2. Quick-Fire Ignition

A transformer sends high voltage to a two pronged spark plug. The spark ignites the fuel/air mixture as it is sprayed into the combustion chamber.

4.1.3. Air System

A fan is turned by the heavy duty motor, which forces air around and into the combustion chamber, where it is super-heated and forced out the front of the chamber.

4.1.4. Electrical System Protection

The heaters' electrical system is protected by a circuit breaker that protects the system components from damage. If the heater fails, check the fuse first, and replace if necessary. (See maintenance).

4.1.5. Flame Sensor

The heater uses a photocell to "see" the flame in the combustion chamber. Should the flame extinguish, the sensor will stop electrical current and the heater will shut off.

4.2. Fuel

The IR18 will operate with two types of fuel, paraffin or diesel.

4.3. When used in the construction or agricultural industries ensure that the safety regulations in force are adhered to with regard to distances from flammable materials and any other specified substances. Refer to Section 2 for recommended clearances.

- ☐ **WARNING! Air contaminants taken into the heater may affect the heat output, damage the unit and may cause health problems. Example: Bodyshop filler dust/paint overspray will damage the motor bearing, clog the filter and compressor and contaminate the combustion chamber causing flame flutter and health hazards. Please note that any parts damaged by filler dust/paint overspray will not be covered by warranty. Additionally, a cleaning charge will be made for any heaters damaged by filler dust/paint overspray.**

4.4. VENTILATION.

- ☐ **WARNING! Only use the heater in well ventilated areas. Careful consideration must be given to the placing of the heater to provide safe and comfortable heating. Ensure continuous ventilation is provided to the heater operating area. A ventilation opening **must** run to the outside of the premises in which the heater is to be operated. The IR18 requires a fresh air opening of at least 0.18m².**

For Example:

- A two car garage door should be open at least 6cm.
- A single car garage should be open at least 8cm.
- Two 82cm windows open at least 11cm.

5. OPERATING INSTRUCTIONS

5.1. STARTING HEATER

- 5.1.1. Fill the fuel tank until the fuel gauge points to "F".
- 5.1.2. Ensure the fuel cap is secure.
- 5.1.3. Plug the power cord into a suitable power socket. If using an extension lead see Section 1.1.10.
- 5.1.4. Push the Power switch (Fig.2) to the "ON" position.

NOTE! The electrical components of this heater are protected by a fuse mounted on the Printed circuit board. If the heater fails to fire, check this fuse first, and replace if necessary. Also check the power source ensuring that the correct voltage is being provided.

5.2. TO STOP THE HEATER

- 5.2.1 Turn the power switch (Fig.2) to the "OFF" position. Combustion will stop and the Cooling Cycle (approx. 4-5minutes) will begin.
- 5.2.2 When Cooling Cycle has completed (fan stops running), **Unplug** the heater from the mains supply.

- ☐ **WARNING! DO NOT DISCONNECT THE POWER SOURCE OR UNPLUG THE POWER CORD UNTIL THE COOLING CYCLE HAS BEEN COMPLETED!**

- ☐ **WARNING! UNPLUGGING THE UNIT BEFORE THE COOLING CYCLE HAS ENDED MAY CAUSE OVERHEATING, POSSIBLE DAMAGE TO THE HEATER AND WILL VOID THE WARRANTY.**

5.3 TO RE-START THE HEATER

- 5.3.1 Re-connect the power supply for the heater.
- 5.3.2 Turn the Power Switch to "ON" position.
- 5.3.3 Be sure to follow all starting procedure precautions.

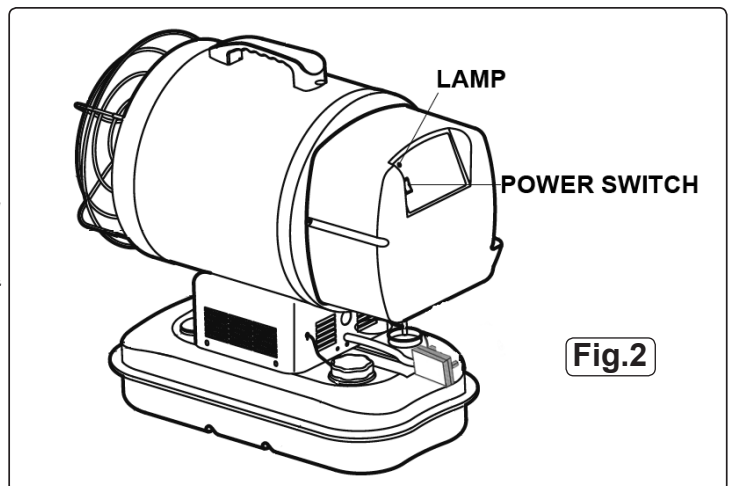

6. MAINTENANCE



WARNING! MAINTENANCE MUST ONLY BE UNDERTAKEN BY A QUALIFIED PERSON. WE STRONGLY RECOMMEND THAT ALL SERVICING IS DONE BY YOUR LOCAL SERVICE AGENT.

❑ **WARNING! Unplug unit from mains power supply before opening or servicing heater.**
See Section 1 regarding electrical safety and maintenance.

Use only genuine Sealey replacement parts. The use of alternate or third party components can cause unsafe operating conditions and will void the warranty.

We suggest following a maintenance schedule as follows:

6.1. FUEL TANK

Flush every 200 hours of operation or as needed. Do Not use water to flush the tank. Use fresh paraffin only.

6.2. FILTERS

The fuel filter and oil filter should be cleaned at least twice per heating season by rinsing it in clean paraffin. Contaminated fuel could make this necessary more frequently. (See Fig.3).

6.3. FAN BLADES

❑ **WARNING! Never service heater whilst hot or connected to an electrical source.**

The fan blades should be cleaned at least once per heating season, depending on conditions. Remove all accumulated dust and dirt with a damp cloth, taking care not to bend any of the fan blades. Be sure fan blades are dry before re-starting the heater. (Fig.4).

6.4. NOZZLES

Nozzles should be cleaned or replaced at least once per heating season. Contaminated fuel could make this necessary more frequently.

To clean nozzle, blow compressed air through nozzle front. It may be necessary to soak nozzle in clean paraffin to help loosen any particles (Fig.5).

6.5. SPARK PLUG (Fig.6)

Clean and re-gap every 600hrs of operation, or replace as needed.

After removing the Spark Plug, clean the terminals with a wire brush. Re-gap the terminals to 0.140" (3.5mm).

6.6. PHOTOCELL

The Photocell should be cleaned at least once per heating season or more depending on conditions.

Use a cotton swab dipped in water or alcohol to clean the lens of the Photocell. Note the Photocell position as Fig.7.

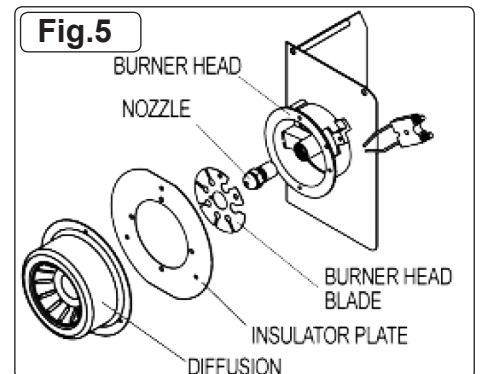
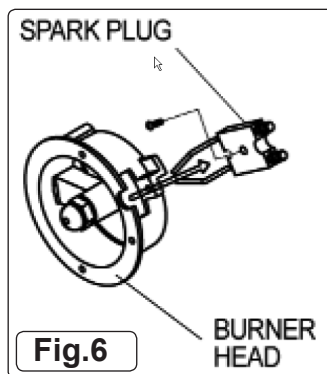
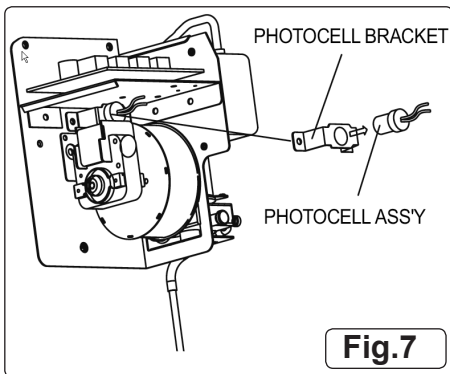
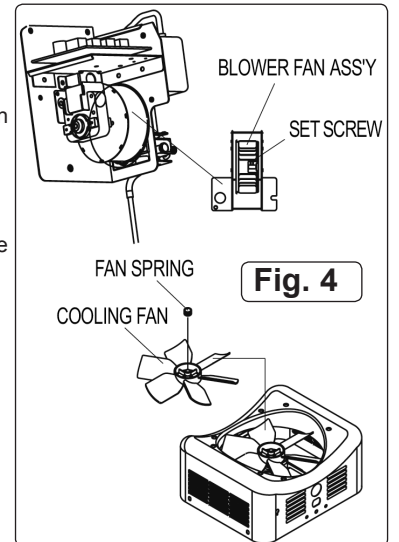
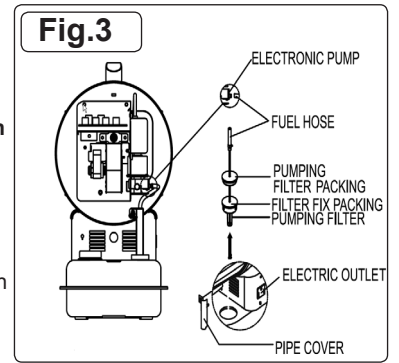

6.7. LONG TERM STORAGE

6.7.1 Unscrew the fuel cap.

6.7.2 Using a syphon suitable for paraffin or diesel to remove the contents of the fuel tank.

6.7.3 Using a small amount of paraffin, rinse and swirl the paraffin inside the fuel tank. Empty tank fully. Never mix water with the paraffin as it will cause the tank to rust.

Never store old fuel in the tank over summer.

Using old fuel can damage your heater.

Store heater in a safe, dry well ventilated area away from children.

Be sure that the storage area is free of dust and corrosive vapours. Re-pack the heater in the original shipping material.

Keep the manual in an easily accessible place.

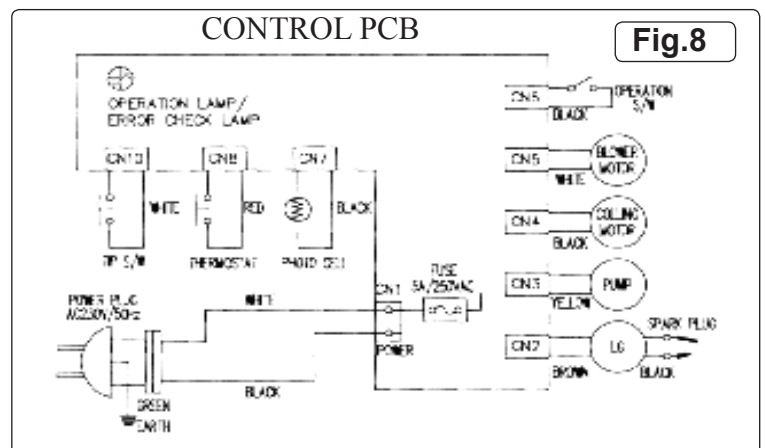

7. TROUBLESHOOTING

Problem	Possible Cause	Solution
Heater fires but shuts down after a short period	1. Dirty Fuel Filter	1. Clean/replace Fuel Filter (See Maintenance)
	2. Nozzle Dirty	2. Clean/replace Nozzle (See Maintenance)
	3. Photocell Dirty	3. Clean/replace Photocell (See Maintenance)
	4. Photocell not installed properly	4. Adjust Photocell position
	5. Photocell defective	5. Replace Photocell
	6. Improper electrical connection between Printed circuit board and Photocell	6. Check wiring connections Fig.8
Heater will not operate or motor runs for short time	1. No paraffin/diesel in fuel tank	1. Fill tank with fresh paraffin/diesel
	2. Corroded spark plug or incorrect gap	2. Clean/replace spark plug (See Maintenance)
	3. Dirty fuel filter	3. Clean/replace fuel filter (See Maintenance)
	4. Dirty Nozzle	4. Clean/replace nozzle (See Maintenance)
	5. Moisture in fuel tank	5. Rinse out fuel tank with clean paraffin (See Maintenance)
	6. Improper electrical connection	6. Inspect all electrical connections (See Wiring Diagram in Maintenance)
	7. Transformer wire not connected to spark plug	7. Re-attach transformer wire to spark plug
	8. Defective transformer	8. Replace transformer
Fan does not operate when heater is plugged in and power switch is in the "ON" position	1. Broken electrical connection between Printed circuit board and motor	1. Inspect all electrical connections (See Wiring Diagram in Maintenance)
Heater does not turn on and lamp is not lit	1. Temperature limit sensor has overheated	1. Push power switch to "OFF" and allow heater to cool for 5 minutes. Push power switch back to "ON"
	2. No electrical power	2. Check power cord to ensure proper connection. Test power supply
	3. Fuse blown	3. Check/replace fuse
	4. Improper electrical connection between temperature limit sensor and Printed circuit board	4. Inspect all electrical connections (See Wiring Diagram in Maintenance)

NOTE: It is our policy to continually improve products and as such we reserve the right to alter data, specifications and component parts without prior notice.

IMPORTANT: No liability is accepted for incorrect use of this product.

WARRANTY: Guarantee is 12 months from purchase date, proof of which will be required for any claim.

INFORMATION: For a copy of our latest catalogue and promotions call us on 01284 757525 and leave your full name and address, including postcode.



Sole UK Distributor, Sealey Group,
Kempson Way, Suffolk Business Park,
Bury St. Edmunds, Suffolk,
IP32 7AR



01284 757500



www.sealey.co.uk



01284 703534



sales@sealey.co.uk