

Thank you for purchasing a Sealey product. Manufactured to a high standard this product will, if used according to these instructions and properly maintained, give you years of trouble free performance.



IMPORTANT: PLEASE READ THESE INSTRUCTIONS CAREFULLY. NOTE THE SAFE OPERATIONAL REQUIREMENTS, WARNINGS AND CAUTIONS. USE THIS PRODUCT CORRECTLY AND WITH CARE FOR THE PURPOSE FOR WHICH IT IS INTENDED. FAILURE TO DO SO MAY CAUSE DAMAGE AND/OR PERSONAL INJURY AND WILL INVALIDATE THE WARRANTY. PLEASE KEEP INSTRUCTIONS SAFE FOR FUTURE USE.

1. SAFETY INSTRUCTIONS

1.1. ELECTRICAL SAFETY.

WARNING! It is the user's responsibility to read, understand and comply with the following:

You must check all electrical equipment and appliances to ensure they are safe before using. You must inspect power supply leads, plugs and all electrical connections for wear and damage. You must ensure the risk of electric shock is minimised by the installation of appropriate safety devices. An RCCB (Residual Current Circuit Breaker) should be incorporated in the main distribution board. We also recommend that an RCD (Residual Current Device) is used with all electrical products. It is particularly important to use an RCD with portable products that are plugged into an electrical supply not protected by an RCCB. If in doubt consult a qualified electrician. You may obtain a Residual Current Device by contacting your Sealey dealer. **You must** also read and understand the following instructions concerning electrical safety.

1.1.1. The **Electricity At Work Act 1989** requires all portable electrical appliances, if used on business premises, to be tested by a qualified electrician, using a Portable Appliance Tester (PAT), at least once a year.

1.1.2. The **Health & Safety at Work Act 1974** makes owners of electrical appliances responsible for the safe condition of the appliance and the safety of the appliance operator. **If in any doubt about electrical safety, contact a qualified electrician.**

1.1.3. Ensure the insulation on all cables and the product itself is safe before connecting to the mains power supply. See 1.1.1. & 1.1.2. above and use a Portable Appliance Tester (PAT).

1.1.4. Ensure that cables are always protected against short circuit and overload.

1.1.5. Regularly inspect power supply, leads, plugs for wear and damage and all electrical connections to ensure that none is loose.

1.1.6. **Important:** Ensure the voltage marked on the product is the same as the electrical power supply to be used and check that plugs are fitted with the correct capacity fuse. A 13 amp plug may require a fuse smaller than 13 amps for certain products, see fuse rating at right.

1.1.7. DO NOT pull or carry the powered appliance by its power supply lead.

1.1.8. DO NOT pull power plugs from sockets by the power cable.

1.1.9. DO NOT use worn or damaged leads, plugs or connections. Immediately replace or have repaired by a qualified electrician. A U.K. 3 pin plug with ASTA/BS approval is fitted. In case of damage, cut off and fit a new plug according to the following instructions (discard old plug safely).

(UK only - see diagram at right). **Ensure the unit is correctly earthed via a three-pin plug.**

a) **Connect the GREEN/YELLOW earth wire to the earth terminal 'E'.**

b) **Connect the BROWN live wire to live terminal 'L'.**

c) **Connect the BLUE neutral wire to the neutral terminal 'N'.**

d) **After wiring, check there are no bare wires, that all wires have been correctly connected, that cable outer insulation extends beyond the cable restraint and that the restraint is tight.**

Double insulated products are often fitted with live (BROWN) and neutral (BLUE) wires only. Double insulated products are always marked with this symbol . **To re-wire, connect the brown and blue wires as indicated above. DO NOT connect the brown or blue to the earth terminal.**

1.1.10. Some products require more than a 13 amp electrical supply. In such a case, **NO** plug will be fitted. **You must** contact a qualified electrician to ensure a 30 amp fused supply is available. We recommend you discuss the installation of a industrial round pin plug and socket with your electrician.

1.1.11. **Cable extension reels.** When a cable extension reel is used it should be fully unwound before connection. A cable reel with an RCD fitted is recommended since any product which is plugged into the cable reel will be protected. The section of the cores of the cable is important. We suggest 1.5mm² section as a minimum but to be absolutely sure that the capacity of the cable reel is suitable for this product and for others that may be used in the other output sockets, we recommend the use of 2.5mm² section cable.

1.2. GENERAL SAFETY.

✓ Familiarise yourself with the application, limitations and potential hazards peculiar to the spray gun.

WARNING! Disconnect the spray gun from the air hose before changing accessories, servicing or performing any maintenance.

✓ Maintain the spray gun in good condition (use an authorised service agent).

✓ Replace or repair damaged parts. *Use recommended parts only. Unauthorised parts may be dangerous and will invalidate the warranty.*

✓ Keep the spray gun clean for best and safest performance.

✓ Wear approved safety respiratory protection and safety goggles.

✓ Remove ill fitting clothing. Remove ties, watches, rings, and other loose jewellery, and tie back long hair.

✓ Locate the spray gun in the desired working area, keep area clean and tidy and free from unrelated materials and ensure that there is adequate ventilation and lighting.

✓ Keep children and unauthorised persons away from the working area.

✓ Avoid unintentional operation.

x DO NOT point spray gun at yourself, other persons or animals.

x DO NOT carry the spray gun by the hose, or yank the hose from the air outlet.

x DO NOT use the spray gun for any purpose other than for which it is designed.

x DO NOT allow untrained persons to operate the spray gun.

x DO NOT get the spray gun wet and DO NOT use outside or in damp or wet locations or areas where there is condensation.

x DO NOT operate the spray gun if any parts are missing or damaged as this may cause failure and/or possible personal injury.

x DO NOT direct air from the air hose at yourself or at others.

✓ When not in use switch the unit off and disconnect from the mains.

x DO NOT use the machine in the presence of flammable liquids or gases.

x DO NOT use the machine on premises where explosive substances are stored.

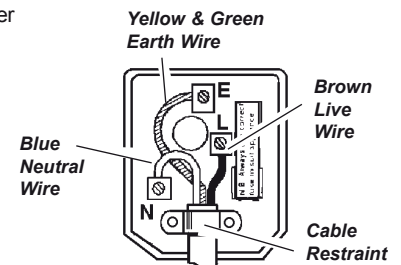

**FUSE RATING
THIS PRODUCT MUST
BE FITTED WITH A
5 AMP FUSE**

- x **DO NOT** open the main unit or loosen or remove any of its retaining screws.
- x **DO NOT** wipe plastic parts with any solvents such as petrol, thinners, carbon tetrachloride, alcohol or ammonia.
- x **DO NOT** mix or thin paint in an area where there may be functioning appliances producing a naked flame or electrical sparking. This includes equipment that is electric motor powered.
- x **DO NOT** switch on the spray gun when paint is being mixed or thinned.
- ✓ Ensure that any vapours have dispersed before switching on the spray gun.
- ✓ Tightly recap all containers immediately after thinning or mixing paint and store away from the spraying area.
- x **DO NOT** spray where there are any sources of ignition such as an open fire, cigarettes, cigars or pipes, sparks, glowing wires or hot surfaces or naked lighting.
- ✓ Ensure that the air hose is firmly connected to the unit and the gun to avoid the possibility of any spill material being drawn into the unit.

2. INTRODUCTION & SPECIFICATION

Utilises 400Watt electric motor with high performance turbine to deliver continuous volumes of air. Spray gun uses composite body, which has low affinity for paint, enabling quick and easy cleaning. Gun includes air and paint controls for fine adjustment of spray pattern. Suitable for interior and exterior use, applying water and oil based paints, lacquers and stains. Supplied with air hose, viscosity cup and shoulder strap.

2.1. Specification

Spray Gun Set-Up.....	.2mm
Max Operating Pressure.....	1.5psi
Voltage.....	.230V
Power Consumption.....	.400W
Air Hose Length.....	.2.7m
Weight.....	.2.3kg



3. PAINT PREPARATION

3.1. Checking paint viscosity.

As most paints are made for brush or roller action it will normally be necessary to thin the paint to achieve proper atomization and good coverage. Use the viscosity cup provided to check the viscosity of the paint prior to thinning (see fig.2). Dip the cup into the paint to completely fill it and then time how long it takes for the paint to flow out again. If the paint is the correct viscosity the flow time will be between 8 and 20 seconds. If the flow time is more than 20 seconds the paint is too thick. Thin the paint slightly and retest until the flow time is within the limits stated. If the flow time is less than eight seconds the paint is too thin.

3.2. Paint condition.

Any debris in the paint will clog the gun which will require a complete strip down and clean before the gun will function again properly. This is particularly important when using paint that has previously been opened. The paint should be thoroughly mixed and free from skin and lumps. If necessary strain the paint through a 60 mesh paint strainer, or a piece of cheesecloth or an old nylon stocking to ensure a smooth finish. The paint should be strained into a clean container and if any paint is left over it should be stored in a clean container.

4. ASSEMBLY / PREPARATION

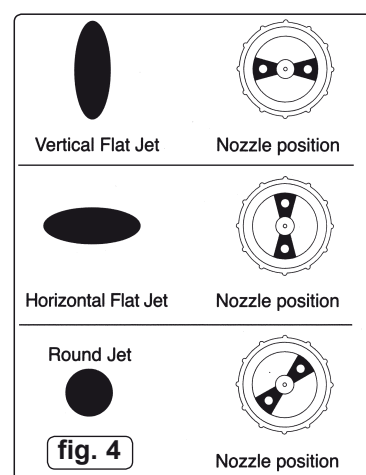
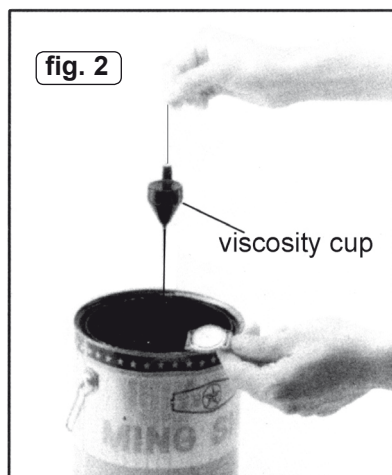

- 4.1. Remove the unit from the packaging and uncoil the power cable from the storage flange at the back of the unit. Do not plug the unit in yet.
- 4.2. Remove the spray gun from the unit and set the air cap to give the required spray pattern. Do this by loosening the air cap locking ring as indicated in fig. 3 and rotating the air cap to give the required spray pattern as shown in fig. 4. Retighten the locking ring.
- 4.3. Unscrew the paint container. Fill container with paint (see Section 3 regarding paint preparation). Refit the paint container to the gun and tighten.
- 4.4. Lay out the air hose and connect one end to the back of the unit using a push and twist action (see fig. 5). Connect the other end of the hose to the gun as shown in fig. 3.
- 4.5. Plug the unit into the mains and switch on. You are now ready to spray.



5. OPERATING INSTRUCTIONS

- 5.1. To adjust the width of the spray pattern turn the fluid control knob as indicated in fig. 3. To reduce the amount of material sprayed screw the knob in. To increase the amount of material sprayed screw the knob out.
- 5.2. Control the air flow using the trigger.
- 5.3. If necessary re-adjust the spray pattern.
- 5.4. Good results will be obtained using a combination of the above adjustments. If you have no previous experience of spraying we suggest that you experiment on a non-essential area first before performing the final spraying operation
- 5.5. For best results, handle the gun correctly. It should be held perpendicular to the surface being sprayed and moved parallel to it. Start the stroke before squeezing the trigger and release the trigger before finishing the stroke. This will give accurate control of the gun and material (fig. 6).
- 5.6. Spray from a distance of about 6 to 10 inches. The material deposited should always be even and wet. Each stroke must overlap the preceding stroke to obtain a uniform finish.

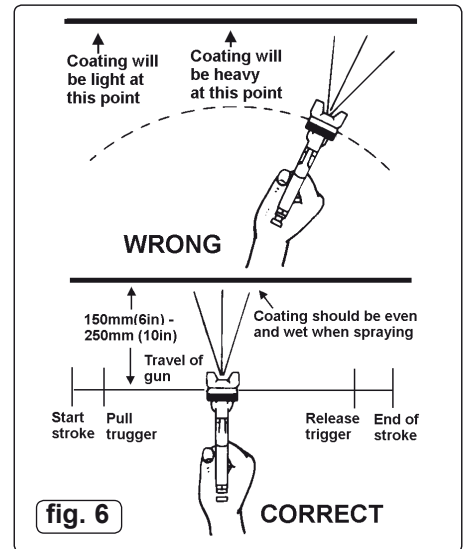

6. CLEANING

- 6.1. **The gun must be cleaned immediately after you have finished using it.** On no account must any paint be allowed to even partially dry as this may make your gun unusable. Empty the paint container immediately and flush it out. If using water based paint refill with clean water and operate the gun until it is spraying clean water only. If using an oil based paint, stain, or lacquer clean the paint container with the appropriate thinning medium then refill the container with the medium and operate the gun until all paint residue has been flushed out.
- 6.2. Clean the outside of the gun and the main unit with a soft cloth soaked in warm soapy water.

7. MAINTENANCE

- 7.1. Switch off the unit and disconnect from the mains before performing any maintenance or cleaning. Disconnect the air hose from the unit and from the spray gun. When reassembling after maintenance, be sure to take care when screwing parts together. At first screw parts hand tight to avoid cross-threading. If a part cannot easily be turned by hand, check that you have the correct part, unscrew, realign and try again. DO NOT use excessive force when reassembling.
- 7.2. **Cleaning the spray gun.** To maintain the spray gun in peak operational condition the main parts as shown in fig.7 should be regularly inspected and cleaned. Metal parts should be soaked in a suitable paint thinning medium. This will normally be the thinning agent used for the paint that was last in the gun. Plastic parts can only be immersed in hot soapy water and brushed clean. Never soak plastic parts in any solvents as this may cause the parts to disintegrate.
- 7.2.1. To disassemble the gun for routine maintenance withdraw the fluid needle (D) first. To do this unscrew and remove the fluid adjusting screw (E) and the spring behind it. Now withdraw the fluid needle. It may be necessary to squeeze the trigger slightly to dislodge the needle.
- 7.2.2. Unscrew the air cap locking ring (A) and remove the air cap (B).
- 7.2.3. Using a suitable spanner unscrew and remove the fluid cap (C).
- 7.2.4. The fluid tube (F) is a push fit into the main body of the gun. To remove for cleaning simply pull it out of its seating.
- 7.2.5. Clean metal and plastic parts as previously directed and then carefully reassemble the gun in the reverse order.
- 7.2.6. Should any deterioration in the performance of your gun occur refer first to the trouble shooting guide below or return the gun to your Sealey service agent.

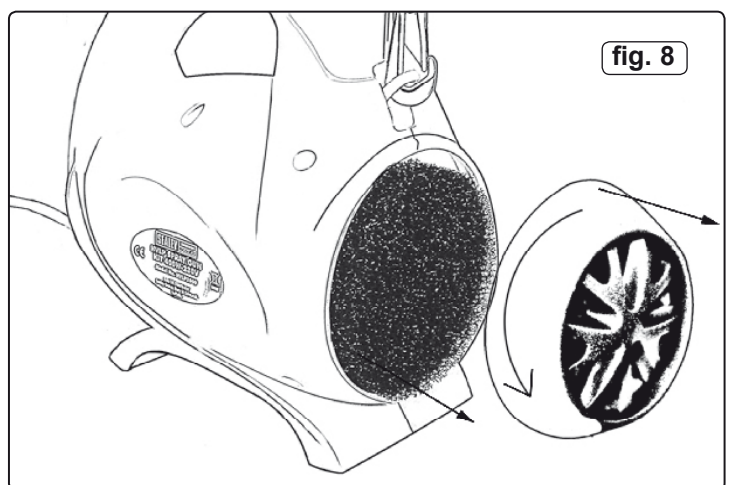
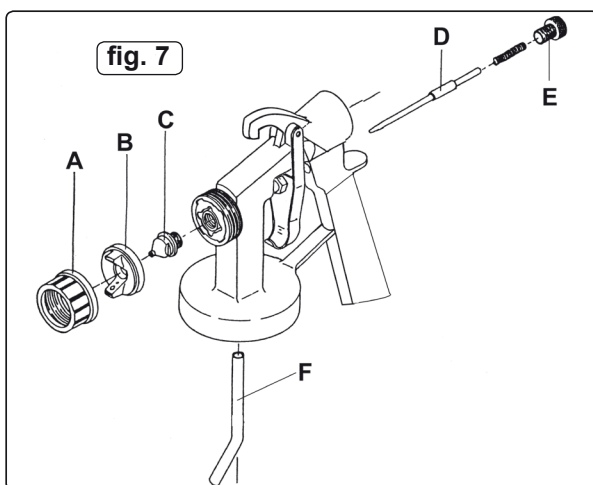







7.3. Cleaning the air filter.

The air filter should be cleaned on a regular basis. Remove the filter cover by twisting counter clock-wise and pulling it off as shown in fig. 8. Remove the foam filter.

If using water based paints clean the filter in mild soapy water and remove excess water by pressing in a soft cloth. Allow to dry flat before reinstalling. Align tabs on the filter cover with the grooves on the main unit and twist clockwise.

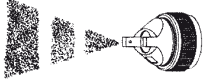
Where a build-up of non-water soluble paint has occurred the filter cannot be cleaned and will have to be replaced. Place the new filter into the back of the filter cover and insert by aligning tabs on the filter cover with grooves on the main unit and twist clockwise, To prolong filter life place the main unit as far away as possible from the spraying area.

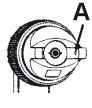
8. TROUBLESHOOTING

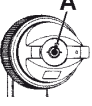
PROBLEM	CAUSE	SOLUTION
Poor atomization, heavy centre pattern 	Fluid flow is too high for the air flow.	1. Reduce paint flow by screwing in the fluid control knob. 2. Paint could be too thick, in which case dilute it.
Heavy atomization, poor centre pattern 	Paint is too thin.	1. Increase proportion of paint to thinning medium
Intermittent spray pattern 	Air entering the paint supply	1. Tighten the connection between the gun and the cup. 2. Tighten fluid nozzle with gun spanner. 3. Check whether paint pot is empty.
Heavy right or left side pattern  	One of the horn holes blocked (A). In order to check, turn the air cap 180°, if the faulty pattern is now reversed the hole must be cleaned.	1. Place the air cap in cleaning solution. 2. Clean hole with compressed air or with a 'soft' probe. DO NOT use a metal probe which will damage the hole.
Top heavy or bottom heavy pattern  	Possible paint build-up between fluid nozzle and air cap (A).	1. Clean the air cap and the fluid nozzle, check also that they match correctly. 2. Check needle for damage.

Environmental Protection.



Recycle unwanted materials instead of disposing of them as waste. All tools, accessories and packaging should be sorted, taken to a recycle centre and disposed of in a manner which is compatible with the environment.



When the product is no longer required, it must be disposed of in an environmentally protective way.

Parts support is available for this product. To obtain a parts listing and/or diagram, please log on to www.sealey.co.uk, email sales@sealey.co.uk or phone 01284 757500.

NOTE: It is our policy to continually improve products and as such we reserve the right to alter data, specifications and component parts without prior notice.

IMPORTANT: No liability is accepted for incorrect use of this product.

WARRANTY: Guarantee is 12 months from purchase date, proof of which will be required for any claim.

INFORMATION: For a copy of our latest catalogue and promotions call us on 01284 757525 and leave your full name and address, including postcode.



Sole UK Distributor, Sealey Group,
Kempson Way, Suffolk Business Park,
Bury St. Edmunds, Suffolk,
IP32 7AR



01284 757500



www.sealey.co.uk



01284 703534



sales@sealey.co.uk